

dataTec

Ihr Ansprechpartner /
Your Partner:

dataTec AG
E-Mail: info@datatec.eu
>>> www.datatec.eu



Authorized
Distributor

Mess- und Prüftechnik. Die Experten.



Product Brochure

PXI Programmable Power Supplies

Contents

[PXI Programmable Power Supplies](#)

[Detailed View](#)

[Key Features](#)

[Software](#)

[Supporting Documentation](#)

[Configure a Custom NI System](#)

[What is PXI?](#)

[PXI Instrumentation](#)

[Hardware Services](#)

PXI Programmable Power Supplies

PXIe-4112, PXIe-4113, and PXIe-4151



FIGURE 1

PXIe-4112, PXIe-4151, and PXIe-4113 Power Supplies

- Software: Includes interactive InstrumentStudio™ soft front panel; API support for LabVIEW, C#/NET, and Python; shipping examples; and detailed help files
- Voltage and current measurements with sample rates up to 1.8 MS/s and update rates up to 100 kS/s
- Ability to source up to 300 W of DC power
- Hardware timing and triggering
- 4-wire remote sense
- Output disconnect feature

Built for Automated Test and Measurement

NI PXI Express power supplies provide up to 300 W in the compact form factor of a PXI module. The high-power delivery and measurement capabilities simplify the task of designing automated test systems by saving expensive rack space and reducing the need for multiple instrument form factors within the test system. The fully programmable power supplies have output disconnect features to isolate the instrument from the device under test (DUT), remote sense to correct for losses in system wiring, and integrated timing and synchronization through the PXI platform. Combining these standard power supply features with a tightly integrated programming API and the PXI platform makes these instruments ideal for automated test applications in semiconductor, aerospace and defense, transportation, consumer electronics, and more.

Table 1. NI programmable power supplies provide reliable and accurate power for a variety of automated test applications.

	<u>PXIe-4112</u>	<u>PXIe-4113</u>	<u>PXIe-4151</u>
Quadrant of Operation	I - Sourcing (III if manually inverted)		
Number of Isolated Channels	2	2	1
Number of PXI Slots	1	1	2
Maximum Voltage (V)	60	10	20
Maximum Current (A)	1	6	25
Maximum Power Per Channel (W)	60	60	300
Maximum Voltage Measurement Resolution	17 mV	3 mV	10 μ V
Maximum Voltage Measurement Accuracy	0.1% + 50 mV	0.1% + 15 mV	0.03% + 1 mV
Maximum Current Measurement Resolution	274 μ A	2 mA	10 nA
Maximum Current Measurement Accuracy	0.15% + 4 mA	0.15% + 20 mA	0.05% + 100 μ A
Maximum Sampling Rate	5.25 kS/s		1.8 MS/s
Output Disconnect Feature	•	•	•
4-Wire Remote Sense	•	•	•
Hardware Timing and Triggering	•	•	•
SourceAdapt Custom Transient Response Tuning	-	-	•
Auxiliary Power Supply	Included with Kit	Included with Kit	<u>APS-4158/9</u>
Chassis Compatibility	38 W, 58 W, or 82 W NI Chassis		

Detailed View of PXIe-4151 Power Supply

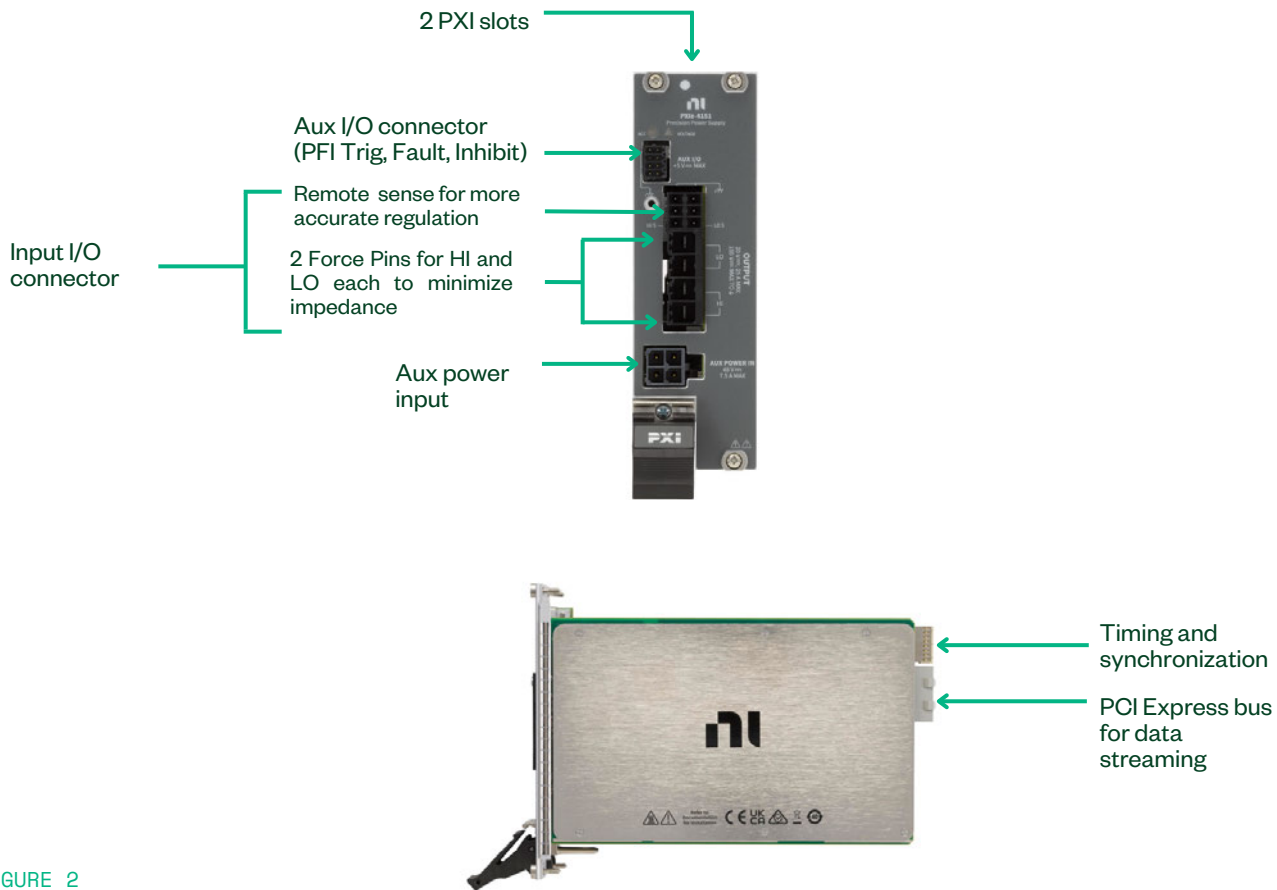

FIGURE 2
Detailed View of the PXIe-4151 Power Supply

Key Features

Accelerate Time to Insights

Get detailed insights thanks to the high accuracy of output values and simultaneous current and voltage measurements and perform fast power supply operations with the high data bandwidth and low latency of PXI. With PXI, data and commands are sent back and forth between the host rapidly, leading to faster data acquisition. Additionally, the power supply provides built-in digital multimeter (DMM)-like measurements up to 1.8 MS/s, preventing the need for an external DMM/scope in most applications. User-programmable source delay and aperture times give you the ability to optimize for both test time and measurement accuracy, and update rates up to 100 kS/s provide the ability to create custom, complex waveforms for even the most dynamic test requirements.

Achieve Higher Accuracy Using Measurement Ranges

Some power supplies offer multiple measurement ranges for both voltage and current to maximize the measurement fidelity and reduce quantization noise. Using the different ranges, you can maximize the accuracy for large or small signals beyond what would be possible using only the full range. In other words, you can optimize the ADC range by using the most appropriate range for the magnitude of the measurement.

Change Voltage Levels Faster

Premium power supplies feature a down-programmer circuit, which is a time-saving feature built into the hardware architecture that operates as a reverse current source. When you change voltage levels, namely when stepping down, the down-programmer stage “pulls” the output down by quickly pulling charge off the instrument’s bulk capacitance. It improves the negative slew rates by creating a forced transient instead of a passive transient. Figure 3 shows the potential difference in output response times with and without this feature.

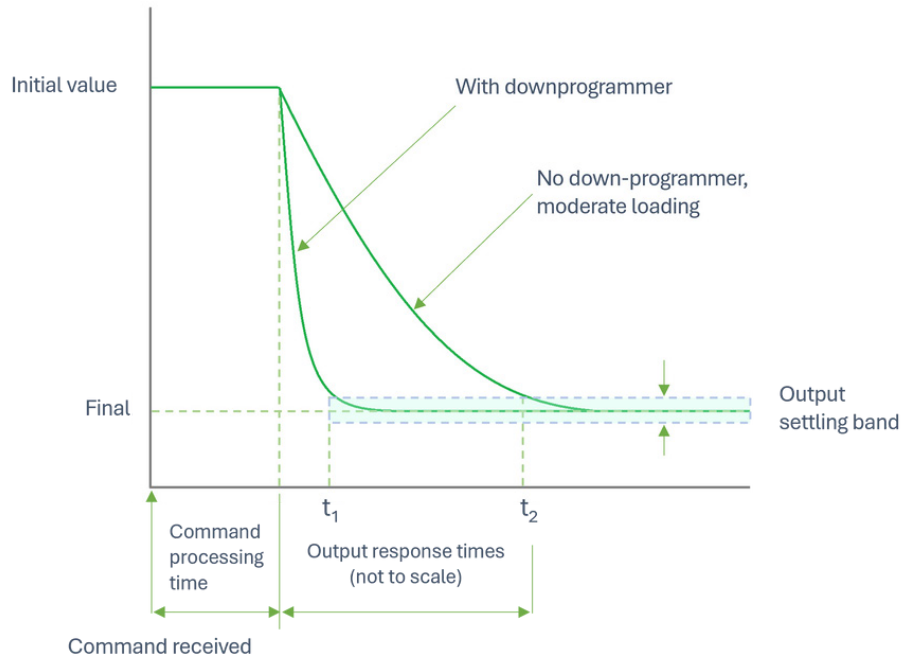

FIGURE 3

The rate at which the instrument responds to a decrease in the voltage level is faster with a down-programmer circuit, sometimes on the order of hundreds of milliseconds or more for high-performance power supplies.

Customize the Transient Response

NI SourceAdapt digital control-loop technology gives you the ability to optimize the instrument's or power supply's response for any DUT. This provides fast and stable measurements for a variety of loads, even highly capacitive or inductive loads, and prevents damage to your DUT by removing harmful overshoots and oscillations. By allowing complete customization of the instrument's or power supply's response, this technology helps you remove unwanted characteristics of the instrument while maintaining a fast settling time—all without adding any custom circuitry between the instrument and the load. Because this capability is handled programmatically, you can quickly reconfigure your instrument or power supply for high-speed or high-stability testing and maximize the usage of your instrument.

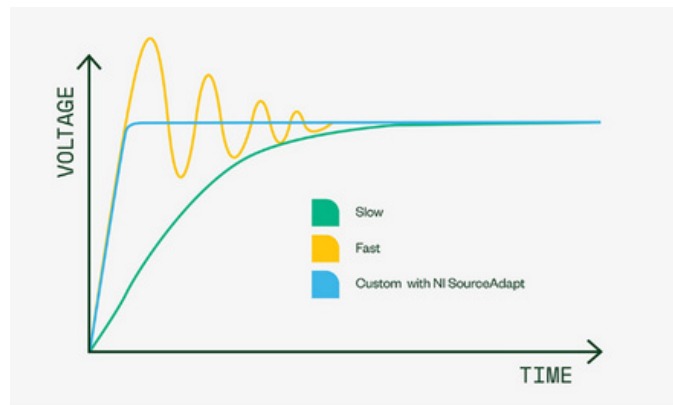

FIGURE 4

The plot of voltage versus time shows an unstable, slow, and optimized instrument response using SourceAdapt.

Use Remote Sense

NI power supplies give you the flexibility to programmatically disconnect the output of the instrument and to configure local or remote sense for each channel. Programmatically disconnecting the output of the power supply allows you to isolate the instrument from your DUT without manually disconnecting the output or routing the power supply through an external relay. Remote sense uses a pair of high-impedance sense lines to measure the voltage at your DUT and compensate for any voltage drop between the terminals of the power supply and the DUT.

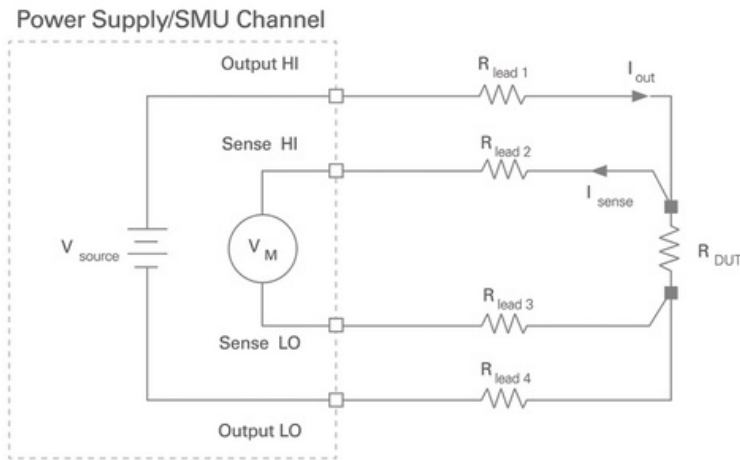

FIGURE 5

With PXI Power Supplies, you can isolate the instrument from your DUT without manually disconnecting the output or routing the power supply through an external relay.

Software

NI-DCPower API

In addition to the soft front panel in InstrumentStudio, the PXI power supplies use the NI-DCPower driver, which includes a best-in-class API that works with a variety of development options such as LabVIEW, C/C++, C#, and others. To ensure long-term interoperability of PXI programmable power instruments, the NI-DCPower driver API is the same API used for all past and current PXI programmable power instruments. The driver also provides access to help files, documentation, and dozens of ready-to-run shipping examples you can use as a starting point for your application.

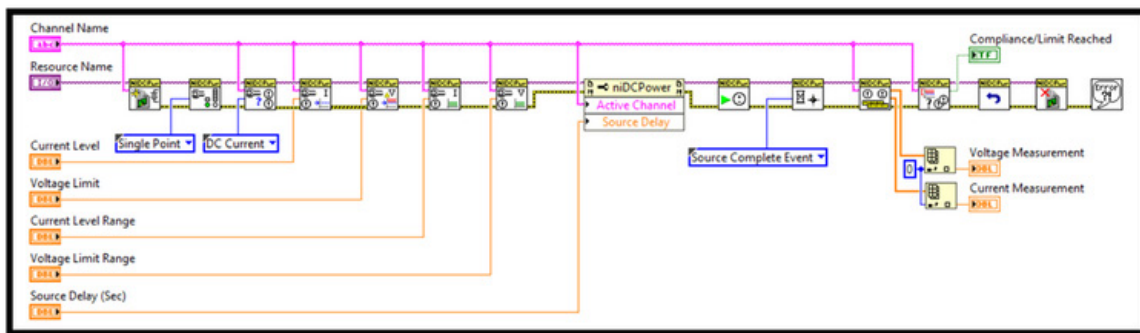

FIGURE 6

LabVIEW VI Using the NI-DCPower API

NI Software- The Right Tool for the Job

NI has a variety of software for engineers working on research, validation, and production test applications. Learn about our software that helps engineers perform quick ad-hoc tests, build an automated test system, automate data analysis and reporting, develop test sequences, and more.

LabVIEW

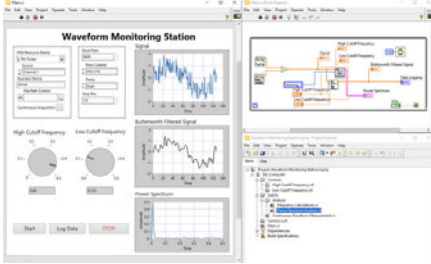

Graphical programming environment that engineers use to develop automated research, validation, and production test systems.

- Acquire data from NI and third-party hardware and communicate using industry protocols
- Use configurable, interactive display elements
- Take advantage of available analysis functions

DIAdem

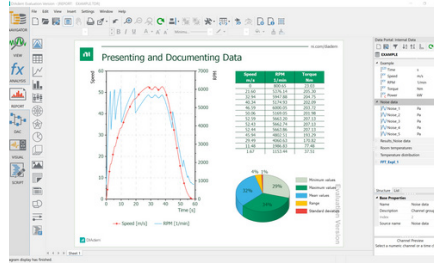

Data analytics software for measurement data search, inspection, analysis, and automated reporting.

- Display data in multiple 2D-axis systems
- Perform calculations with a simple point-and-click interface
- Automate your measurement data analysis workflow, from import to analysis

TestStand

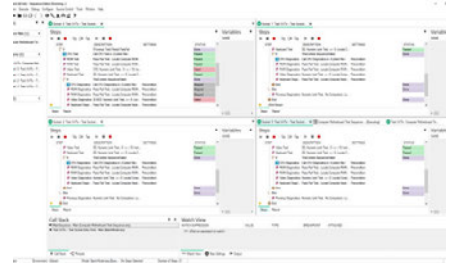

Test executive software that accelerates system development for engineers in validation and production.

- Call and execute tests in LabVIEW, Python, C/C++, or .NET
- Conduct complex tasks, such as parallel testing
- Create customer operator interfaces and robust tools for deployment and debugging

G Web

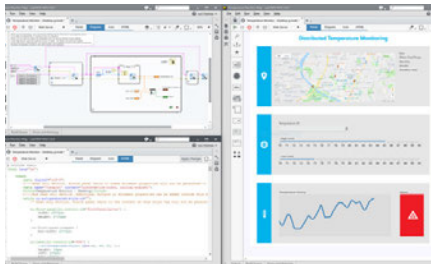

Development software that helps engineers create web-based user interfaces without the need for traditional web development skills.

- Data transfer APIs for connecting to systems written in LabVIEW, Python, or C#
- Pre-built objects for data display and user input
- Included hosting on SystemLink™ Cloud

FlexLogger™

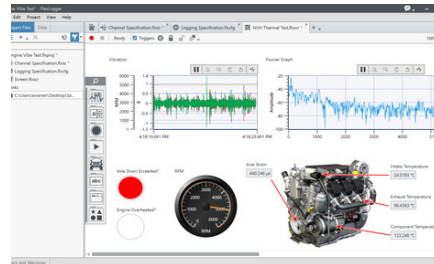

No-code data acquisition software engineers use to build validation and verification test applications.

- Interactive visualization tools for monitoring tests with drag-and-drop charts, graphs, and controls
- Ability to set alarms that monitor single channels or groups for unexpected behavior

InstrumentStudio™



Application software that simplifies setup and configuration of NI PXI hardware

- Customizable layouts for monitoring multiple instruments at once
- Interactively debug in tandem with code
- TDMS file export containing instrument settings, measurements, and raw data

Supporting Documentation

Table 2. PXI Programmable Power Supply Documentation

Document Type	Model
Getting Started Guide	PXle-4112 , PXle-4113 , PXle-4151
Specifications	PXle-4112 , PXle-4113 , PXle-4151

Configure a Custom NI System

NI's online system advisors help you create a custom system based on your specific requirements. Use the advisor to choose compatible hardware, software, accessories, and services and then save your selections as configurations for easy quoting and purchasing later. Visit ni.com/advisor to learn more.

What Is PXI?



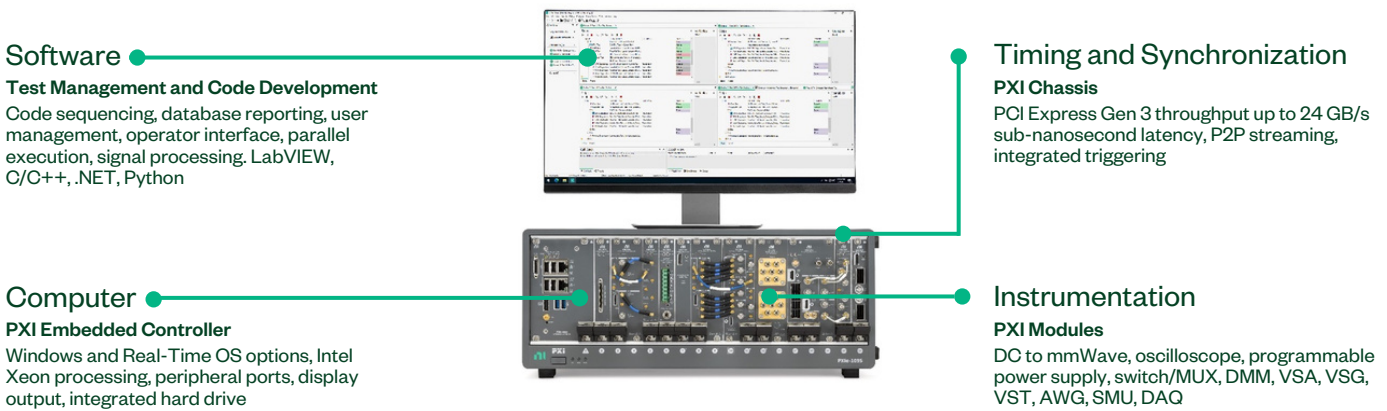

A Platform Approach to Test and Measurement

Powered by software, PXI is a rugged PC-based platform for measurement and automation systems. PXI combines PCI electrical-bus features with the modular, Eurocard packaging of CompactPCI and then adds specialized synchronization buses and key software features. PXI is both a high-performance and low-cost deployment platform for applications such as manufacturing test, military and aerospace, machine monitoring, automotive, and industrial test. Developed in 1997 and launched in 1998, PXI is an open industry standard governed by the PXI Systems Alliance (PXISA), a group of more than 70 companies chartered to promote the PXI standard, ensure interoperability, and maintain the PXI specification.



Integrated with the Latest Commercial Technology

By leveraging the latest commercial technology for our products, we can continually deliver high performance and high-quality products to our users at a competitive price. The latest PCI Express Gen 3 switches deliver higher data throughput, the latest Intel multicore processors facilitate faster and more efficient parallel (multisite) testing, the latest FPGAs from Xilinx help to push signal processing algorithms to the edge to accelerate measurements, and the latest data converters from TI and ADI continually increase the measurement range and performance of our instrumentation.

HIGHER DATA THROUGHPUT  PCI Express Gen 3	PARALLEL TEST EXECUTION  Multicore Processors	MEASUREMENT ACCELERATION  FPGAs	INCREASED MEASUREMENT RANGE  Data Converters
--	--	---	---

PXI Instrumentation

NI offers more than 600 different PXI modules ranging from DC to mmWave. Because PXI is an open industry standard, nearly 1,500 products are available from more than 70 different instrument vendors. With standard processing and control functions designated to a controller, PXI instruments need to contain only the actual instrumentation circuitry, which provides effective performance in a small footprint. Combined with a chassis and controller, PXI systems feature high-throughput data movement using PCI Express bus interfaces and sub-nanosecond synchronization with integrated timing and triggering.



Oscilloscopes

Sample at speeds up to 12.5 GS/s with 5 GHz of analog bandwidth, featuring numerous triggering modes and deep onboard memory



Digital Multimeters

Perform voltage (up to 1000 V), current (up to 3A), resistance, inductance, capacitance, and frequency/period measurements, as well as diode tests



Digital Instruments

Perform characterization and production test of semiconductor devices with timing sets and per channel pin parametric measurement unit (PPMU)



Waveform Generators

Generate standard functions including sine, square, triangle, and ramp as well as user-defined, arbitrary waveforms



Frequency Counters

Perform counter timer tasks such as event counting and encoder position, period, pulse, and frequency measurements



Source Measure Units

Combine high-precision source and measure capability with high channel density, deterministic hardware sequencing, and SourceAdapt transient optimization



Power Supplies & Loads

Supply programmable DC power, with some modules including isolated channels, output disconnect functionality, and remote sense



FlexRIO Custom Instruments & Processing

Provide high-performance I/O and powerful FPGAs for applications that require more than standard instruments can offer



Switches (Matrix & MUX)

Feature a variety of relay types and row/column configurations to simplify wiring in automated test systems



Vector Signal Transceivers

Combine a vector signal generator and vector signal analyzer with FPGA-based, real-time signal processing and control



GPIB, Serial, & Ethernet

Integrate non-PXI instruments into a PXI system through various instrument control interfaces



Data Acquisition Modules

Provide a mix of analog I/O, digital I/O, counter/timer, and trigger functionality for measuring electrical or physical phenomena

NI Hardware Services

All NI hardware includes a one-year warranty for basic repair coverage and calibration in adherence to NI specifications prior to shipment. PXI systems also include basic assembly and a functional test. NI offers additional entitlements to improve uptime and lower maintenance costs with service programs for hardware. Learn more at ni.com/services/hardware.

	Hardware	Standard	Premium	Description
Duration at Point of Sale	1 year; included	3 years; optional	3 years; optional	NI enhances warranty coverage with additional service benefits provided with a hardware service program.
Maximum Duration with Renewal	≤3 years with service program	≤3 years	≤3 years	NI maintains the high performance and availability of your hardware for up to three years with a hardware service program.
Extended Repair Coverage	•	•	•	NI restores your device's functionality and includes firmware updates and factory calibration; < 10 working days ⁴ + standard shipping.
System Configuration, Assembly, and Test ¹		•	•	NI technicians assemble, install software in, and test your system per your custom configuration prior to shipment.
Advanced Replacement ²			•	NI stocks replacement hardware that can be shipped immediately if a repair is needed.
System Return Material Authorization (RMA) ¹			•	NI accepts the delivery of fully assembled systems when performing repair services.
Technical Support	•	•	•	NI provides access to support resources for your hardware.
Calibration Plan (Optional)		Standard	Expedited ³	NI performs the requested level of calibration at the specified calibration interval for the duration of the service program.

¹ This option is only available for PXI, CompactRIO, and CompactDAQ systems.

² This option is not available for all products in all countries. Contact your local NI sales engineer to confirm availability.

³ Expedited calibration is only available for the Traceable calibration level.

⁴ This applies to non-RF products only. Standard extended repair coverage for RF products is <15 working days + standard shipping.

PremiumPlus Service Program

NI can customize the offerings listed above or offer additional entitlements such as on-site calibration, custom sparring, and lifecycle services through a [PremiumPlus Service Program](#). Contact your NI sales representative to learn more.

Technical Support

NI hardware service programs and warranty include access to technical support provided by NI support agents during local business hours. Service requests can be managed online. Additionally, take advantage of NI's award-winning [online resources](#) and [communities](#).

©2023 National Instruments Corporation. All rights reserved. National Instruments, NI, and ni.com are trademarks of National Instruments. Other product and company names listed are trademarks or trade names of their respective companies. All rights reserved. National Instruments, NI, and ni.com are trademarks of National Instruments.



Mess- und Prüftechnik. Die Experten.

Ihr Ansprechpartner /
Your Partner:

dataTec AG

E-Mail: info@datatec.eu

>>> www.datatec.eu

