

34980A

Data acquisition system

Introduction

The 34980A multifunction switch/measure unit provides functionality that is easy to set up and use with a fast startup time. The 34980A helps you lower your test cost and accelerate your test-system integration and development.



dataTec

Mess- und Prüftechnik. Die Experten.

**Ihr Ansprechpartner /
Your Partner:**

dataTec AG
E-Mail: info@datatec.eu
>>> www.datatec.eu

 **KEYSIGHT**
Authorized Premium
Distributor

Table of Contents

High-performance Data Acquisition System Provides a Low-cost, Highly Flexible Measurement Platform 3 Flexible Switching, Measurements, and System Control.....	3
Optimized for Test Systems	4
Measurements You Can Trust	5
Modules Provide Flexible System Stimulus and Control	6
Standard Interfaces Take the Hassle Out of Connecting to Your PC.....	6
Remote Access and Control	6
BenchVue Data Acquisition Control and Analysis	7
Power and Flexibility to Get Your Job Done	8
Mix and Match 34980A Modules to Create Your Own Custom Configuration.....	9
34980A Multiplexer Switch Modules	11
34980A Matrix Switch Modules.....	14
34980A General-Purpose Switch Modules	17
34980A RF and Microwave Switch Modules	19
34946A/47A—From DC to 26.5 GHz.....	20
34946A/47A Option 001	21
34945A/34945EXT Microwave Switch/Attenuator Driver	23
34980A System Control Modules	25
34951A 4-Channel Isolated D/A Converter with Waveform Memory	28
34952A Multifunction Module with 32-bit DIO, 2-Channel D/A and Totalizer	30
34959A Breadboard Component Module	32
34980A System Specifications and Characteristics	34
Typical System Speeds (measurements made on a 3.2GHz PC running VB6 in Windows XP Pro).....	36
Measurement Characteristics with Optional Internal DMM.....	39
General Specifications	42
Definitions for Specifications	44
Ordering Instructions.....	44

High-performance Data Acquisition System Provides a Low-cost, Highly Flexible Measurement Platform

Suppose you use automated test equipment for design validation or manufacturing. In that case, you now have a cost-effective solution for many test system applications. The 34980A multifunction switch/measure unit provides functionality that is easy to set up and use with a fast startup time. The 34980A helps you lower your cost of tests and accelerate your test-system integration and development

The 34980A handles system switching up to 26.5 GHz and provides basic measurements and system control. It also offers DMM measurements, counter/ totalizer functionality, digital I/O with pattern capabilities, and analog outputs with basic waveforms— all in one low-cost, compact box. And with its standard connectors and software drivers, computer-standard I/O, and Web browser interface, the 34980A easily integrates into electronic functional test and data acquisition systems.

Flexible Switching, Measurements, and System Control

The 34980A accommodates up to 8 plug-in modules to give you the flexibility you need. Choose from 21 different modules to define your own configuration. You can buy what you need now and add to it or reconfigure it as your requirements change.

Whether you are measuring temperature, AC or DC voltage, resistance, frequency, current, or custom measurements, the 34980A offers the functionality you need in a single box. Switch in different measurements with high-performance signal switching up to 300V with no external signal conditioning required. Choose between different switch types and topologies with frequency ranges from DC to 26.5 GHz. The 34980A offers high-density multiplexers for scanning multiple channels, matrices for connecting multiple points at one time, and general-purpose switches for simple control and high power needs.

Use the 34980A to individually route signals or monitor multiple signals over a specified period of time — monitor a single channel or multiple channels, set alarms, and identify irregularities.

The 34980A offers flexible choices for system control. You can control external devices such as microwave switches, attenuators, solenoids, and power relays. Or you can use the digital inputs to sense limit-switch and digital-bus status.

Optimized for Test Systems

The 34980A has the performance you need for medium- to high-density switching/measurement applications such as design verification, functional test, and data acquisition. Your signals are switched to the right measurement device without compromising signal integrity. Switch your signals to the optional internal DMM and achieve optimal throughput on switch closure time. Or, if you prefer, you can easily connect to external instruments such as DMMs, scopes, power supplies, and more. What's more, with the built-in Ethernet interface, you can control the 34980A and collect data from anywhere on the network. For a complete modular solution, use the 34980A together with PXI modular products when more capability is required.

The rugged instrument comes with a variety of system-ready features:

- Web browser interface shows settings at a glance and provides remote access and control when using a browser that supports Java applets.
- Self-guiding front panel to configure, troubleshoot or view data
- Low EMI and efficient system cooling
- Heavy-duty cabling and connection options
- Flexible rack mounting options
- Relay counters help predict end-of-life
- In-rack calibration for reduced maintenance time
- DMM measurement accuracies include the switch for simple calculations

Make system connections easily and quickly with simple, reliable connection options:

- Built-in Ethernet, USB 2.0, and GPIB connectivity
- Low-cost, standard 50- or 78-pin Dsub connectors and cables
- Detachable terminal blocks with strain relief
- Mass interconnect solutions

Keysight Technologies, Inc. IO Libraries Suite enables you to quickly establish an error-free connection between your PC and instruments—regardless of vendor. The IO Libraries provide robust instrument control and enable you to work with the software development environment you choose.

The 34980A provides four 2-wire internal analog buses for easy signal routing. You can route your measurements directly to the internal DMM, or you can connect to external instruments through the analog bus connector on the rear of the mainframe. And since you have four 2-wire buses, you can dedicate one bus for use with the internal DMM and use the other three buses for module extensions or additional signal routing between modules which can reduce wiring complexity.

You can define up to 500 switch sequences to control complex signal routing and the order of switch closures. Assign a sequence, give it a name and then execute it with the name you create. Switch sequences are downloaded and stored in the instrument for ease of programming and increased throughput.

External trigger capabilities make it easy for you to time and synchronize measurements and other events and control when to begin or end an acquisition.

Measurements You Can Trust

Get proven performance from Keysight instruments with the resolution, repeatability, speed, and accuracy you've come to expect.

The 34980A offers built-in signal conditioning and modular flexibility. When you use it with the internal DMM, you can configure each channel independently for the measurements you choose. It includes a variety of features that give you confidence in your measurements:

- 6½ digits of resolution with .004% of accuracy with DC voltage measurements
- Alarms per channel—high limit, low limit, or both
- Math functions—use $Mx+B$ for custom linear conversions and converting raw inputs
- Built-in thermocouple reference for temperature measurements (34921T)
- Time-stamped readings
- Add more formulas with BenchVue DAQ

The integrated DMM is mounted inside the mainframe and does not consume any of the eight user-available slots. You can access the DMM through any switch module that connects to the analog bus, or directly from the analog bus connector on the rear of the mainframe. The internal DMM gives you the flexibility to measure 11 types of inputs:

- Temperature with thermocouples, RTDs, or thermistors (with 34921A)
- DC and AC voltage
- 2- and 4-wire resistance
- Frequency and period
- DC and AC current

You can control the DMM directly or configure it to work in conjunction with the switches. Each switch channel can be configured independently for measurement functions, scale factors, and alarm limits. Advanced measurement features such as offset compensation, variable integration time, and delay are also selectable on a per-channel basis.

The DMM inputs are shielded and optically isolated from the 34980A's earth-referenced circuitry and computer interface, and as a result, you get up to 300 V of input isolation. This is important for reducing ground-loops and common-mode voltage errors associated with long wiring runs and floating sources.

Simple DMM calibration is accomplished with just the analog bus connection on the rear panel of the mainframe. You don't need to remove the mainframe from the rack or dedicate a channel for calibration.

Modules Provide Flexible System Stimulus and Control

System control—with analog outputs, open-collector digital outputs, clock generation, and isolated Form-C relays for controlling external devices. Additionally, with the microwave switch/attenuator driver, high-frequency switches and attenuators can be efficiently controlled externally to the 34980A mainframe.

Analog sources—output either voltage or current. You can configure the 4-channel isolated D/A converter as a point-to-point arbitrary waveform generator that lets you define up to 500,000 points per waveform.

Digital patterns—send or receive digital data from your device under test. With onboard memory, you can output communication protocols and bitstreams or monitor digital input patterns and interrupt when a user-defined pattern is detected.

Standard Interfaces Take the Hassle Out of Connecting to Your PC

Standard Ethernet, USB, and GPIB interfaces are included in every mainframe. Use one of the built-in interfaces that are already available in your computer, or if you prefer, GPIB is still available.

- USB offers the quickest and easiest connection scheme—it's perfect for small systems and bench connections.
- Ethernet offers high-speed connections that allow for remote access and control. Choose a local area network to filter out unwanted LAN traffic and speed up the I/O throughput. Or take advantage of the remote capabilities and distribute your tests worldwide. Use the graphical Web browser to monitor, troubleshoot, or debug your application remotely.
- GPIB has many years of proven reliability for instrument communication and can be used in existing GPIB-based test systems.

Remote Access and Control

The built-in Web browser interface provides remote access and control of the instrument via a Java applet-enabled browser such as Internet Explorer version 11. Using the Web interface, you can set up, troubleshoot, and maintain your system remotely:

- View and modify instrument setup
- Open, close, or monitor switches
- Send SCPI commands
- Define and execute switch scans and switch sequences
- View error queue
- Get status reports on relay counts, firmware revisions, and more

Additionally, since the Web interface is built into the instrument, you can access it on any operating system that supports the Web browser without having to install any special software. Password protection and LAN lock-out are also provided to limit access. The Web interface makes it easy to set up, troubleshoot, and maintain your system remotely.

Work with your choice of software so you can save time and preserve your software and hardware investments. Program directly with SCPI, or use IVI or LabVIEW software drivers that provide compatibility with the most popular development environments and tools:

- Keysight VEE Pro
- National Instruments LabVIEW, LabWindows/CVI, TestStand, and Switch Executive
- Microsoft Visual Studio.NET, C/C++, and Visual Basic 6

BenchVue Data Acquisition Control and Analysis

The BenchVue software platform enables you to easily connect to and control the 34980A using the BenchVue DAQ application. This application enables you to quickly configure channels, log data, and visualize measurements for 11 of the 21 plug-in modules. Simply identify the measurements you want to acquire, initiate the process and see the data displayed in real-time. The rich set of colorful graphics provides many options for analyzing and displaying your data. You can specify multiple channels per graph or send collected data to multiple graphs. You can use strip charts with markers and alarm indications or histograms with statistics. And, of course, you can use BenchVue to easily move data to other applications for further analysis or for inclusion in your presentations and reports.



Figure 1. BenchVue DAQ

Power and Flexibility to Get Your Job Done

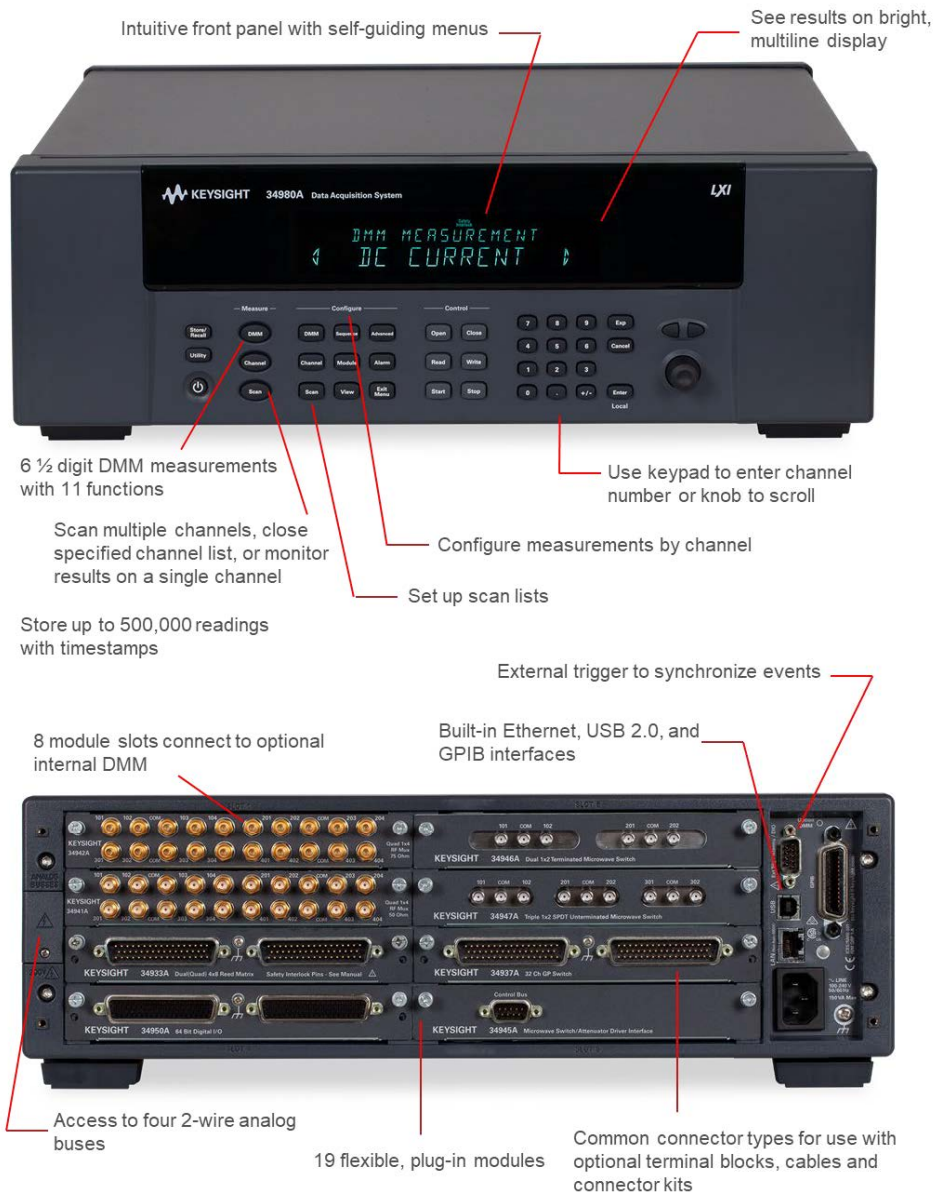

Analog Bus / Internal DMM

Max volts	Switch/Carry current	BW (MHz)	Power (VA)	Volt-Hertz limit	Max Transients ⁴	Scan ch/sec	Thermal offset	Comments
± 300 V ^{1,2}	1A /2A	45 MHz	60 VA ³	10 ⁸	1000Vpk	N/A	N/A	Config as 2- or 4-wire

Notes:

1. Pollution Degree 1 ±300 Vrms or VDC; Pollution Degree 2 ±100 Vrms or VDC.
2. DC or AC RMS voltage, channel-to-channel or channel-to-earth.
3. Limited to 6 W of channel resistance power loss per module.
4. Transient overvoltage is defined as a short duration overvoltage of a few milliseconds or less, oscillatory or non-oscillatory, usually highly damped (IEC 61010-1).

Mix and Match 34980A Modules to Create Your Own Custom Configuration

The 34980A mainframe holds up to eight plug-in modules. Mix and match them to create a custom system to meet your switching and system control needs. You can easily add or replace modules as your needs change

Module	Description	Max volts ⁵	Switch/Carry current	BW (MHz)	Scan ch/sec	Thermal offset	Comments
Multiplexer modules							
34921A	40-channel armature multiplexer w/low thermal offset	$\pm 300\text{ V}^{1,6}$	1A /2A	45 MHz	100	< 3 μV	Temperature reference 4 current channels Config as 2- or 4-wire
34922A	70-channel armature multiplexer	$\pm 300\text{ V}^{1,6}$	1A /2A	25 MHz	100	< 3 μV	Config as 2- or 4-wire
34923A	40/80-channel reed multiplexer	$\pm 150\text{ V}^{2,7}$	0.5A /1.5A	45 MHz	500	< 50 μV	Config as 1-, 2- or 4-wire
34924A	70-channel reed multiplexer	$\pm 150\text{ V}^{2,7}$	0.5A /1.5A	25 MHz	500	< 50 μV	Config as 2- or 4-wire
34925A	40/80-channel optically isolated FET multiplexer	$\pm 80\text{ V}_{\text{peak}}^6$	0.02A	1 MHz	1000	< 3 μV	Config as 1-, 2- or 4-wire
Matrix modules							
34931A	Dual 4x8 armature matrix	$\pm 300\text{ V}^{1,6}$	1A /2A	30 MHz	100	< 3 μV	Backplane expandable
34932A	Dual 4x16 armature matrix	$\pm 300\text{ V}^{1,6}$	1A /2A	30 MHz	100	< 3 μV	Backplane expandable
34933A	Dual/Quad 4x8 reed matrix	$\pm 150\text{ V}^{2,7}$	0.5A /1.5A	30 MHz	500	< 50 μV	Backplane expandable Config as 1- or 2-wire
34934A	Quad 4x32 reed matrix	$\pm 100\text{V}_{\text{peak}}^8$	0.5A /0.5A	20MHz	500	< 50 μV	Row expansion kit. Config as 1- or 2-wire
General-purpose modules							
34937A	28-channel Form C and 4-channel Form A	$\pm 300\text{ V}^{1,6}$ $\pm 250\text{ VAC}^{3,6}$	1A /2A 5A/7A	10 MHz	N/A	< 3 μV < 3 μV	
34938A	20-channel 5-amp Form A	$\pm 250\text{ VAC}^{3,6}$	5A /7A	1 MHz	N/A	< 3 μV	
34939A	64-channels Form A	$\pm 100\text{ V}_{\text{peak}}^{4,6}$	1A /2A	10 MHz	N/A	< 3 μV	

Notes:

1. Pollution Degree 1 $\pm 300\text{ Vrms}$ or VDC; Pollution Degree 2 $\pm 100\text{ Vrms}$ or VDC
2. Pollution Degree 1 $\pm 150\text{ Vpeak}$; Pollution Degree 2 $\pm 100\text{ Vpeak}$
3. Pollution Degree 1 $\pm 250\text{ Vrms}$ or 30 VDC; Pollution Degree 2 $\pm 100\text{ Vrms}$ or 30 VDC
4. Pollution Degree 1 and Pollution Degree 2 $\pm 100\text{ Vrms}$ or VDC
5. Transient overvoltage is defined as a short duration overvoltage of a few milliseconds or less, oscillatory or non-oscillatory, usually highly damped (IEC 61010-1).
6. 1000Vpk transients.
7. 750Vpk transients.
8. 450Vpk transients.

Module	Description	Insertion loss	Isolation	Freq range	VSWR	Input impedance	Comments
RF and microwave modules							
34941A	Quad 1x4 50 ohm 3 GHz RF multiplexer	0.6 dB	> 58 dB	3 GHz	< 1.25	50 Ω	@ 1 GHz
34942A	Quad 1x4 75 ohm 1.5 GHz RF multiplexer	0.6 dB	> 60 dB	1.5 GHz	< 1.35	75 Ω	@ 1 GHz
34945A / 34945EXT	Microwave switch/attenuator driver	Can drive up to 64 external switch coils; 32 SPDT switches, 8 multiport switches, 8 attenuators, or your own combination. Expand with additional 34945EXTs					
34946A	Dual 1x2 SPDT terminated microwave switch	< 0.42 dB < 0.69 dB < 0.8 dB	> 85 dB > 67 dB > 60 dB	4 GHz or 20 GHz 26.5 GHz	< 1.15 < 1.30 < 1.6	50 Ω	@ 4 GHz @ 20 GHz @ 26.5 GHz
34947A	Triple 1x2 SPDT unterminated microwave switch	< 0.42 dB < 0.69 dB < 0.8 dB	> 85 dB < 0.69 dB < 0.8 dB	4 GHz or 20 GHz 26.5 GHz	< 1.15 < 1.30 < 1.6	50 Ω	@ 4 GHz @ 20 GHz @ 26.5 GHz

Module	Description	Comment
System control modules		
34950A	64-bit digital I/O with memory and counter	Eight 8-bit digital I/O channels with programmable polarity, thresholds up to 5 V, with handshaking protocols, and pattern memory. Two 10 MHz frequency counter and programmable clock output to 20 MHz
34951A	4-channel isolated D/A converter with waveform memory	Output DC voltage up to ± 16 V or DC current up to ± 20 mA. Output waveforms with a 200 kHz update rate and 16 bits of resolution. Use on-board memory to create point-to-point waveforms with more than 500,000 points.
34952A	Multifunction module with 32-bit DIO, 2-ch D/A, and totalizer	Four 8-bit digital I/O channels, two ± 12-V analog outputs, and a 100 kHz gated totalizer.
34959A	Breadboard component module	Create your own custom designs with access to the +12 V and +5 V supplies, 16 GPIO ports, 4 Analog Bus drivelines, and 28 relay drivelines. Alternatively, you may use the 4 Analog Bus drivelines as 4 additional general-purpose relay drivelines. Refer to Internal DMM / Analog Bus ratings.

34980A Multiplexer Switch Modules

The 34980A multiplexer modules can be used to connect one of many different points to a single point. You can connect to an external instrument or scan multiple analog signals to the internal DMM.

Choose from the following features:

- 1-wire, 2-wire, or 4-wire configurations
- High voltage—up to 300 V, 1 A
- High density—70 2-wire or 80 1-wire channels
- Scan up to 1000ch/sec with the 34925A
- Bandwidths up to 45 MHz
- Temperature measurements with built-in thermocouple reference junction (34921T)
- AC or DC current measurements without external shunts
- Flexible connections via standard 50- or 78- pin Dsub cables or detachable terminal blocks

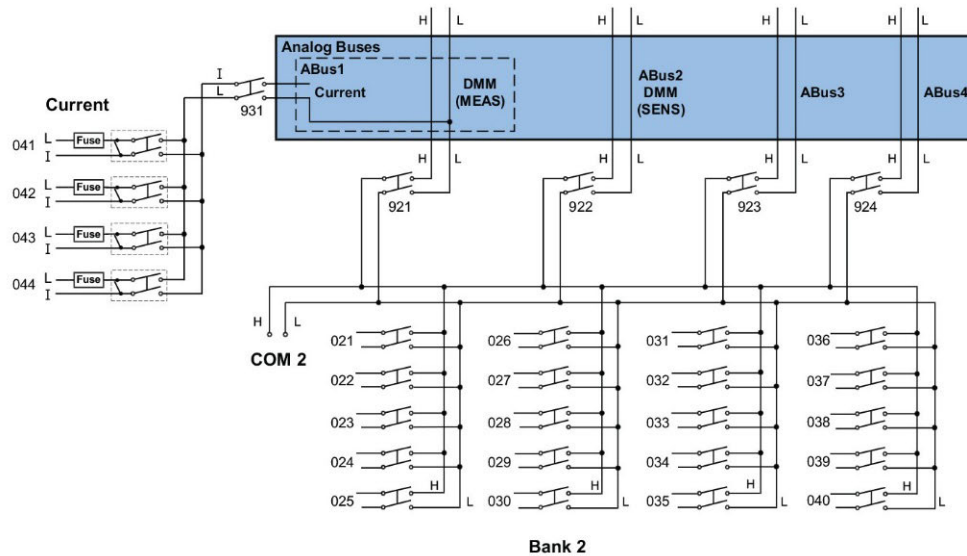

Figure 2. 34921A 40-channel armature multiplexer with low thermal offset (bank 2)

	Voltage AC/DC	Current AC/DC	Freq/ Period	Ω 2- Wire	Ω 4- Wire	Thermocouple	RTD 2-Wire	RTD 4-Wire	Thermistor
34921A Armature Multiplexer	Yes	Yes	Yes	Yes	Yes	Yes	Yes	Yes	Yes
34922A Armature Multiplexer	Yes	No	Yes	Yes	Yes	Yes	Yes	Yes	Yes
34923A Reed Multiplexer (2-wire)	Yes	No	Yes	Yes	Yes	Yes	Yes	Yes	Yes
34923A Reed Multiplexer (1-wire)	Yes	No	Yes	Yes	No	Yes	Yes	No	Yes
34924A Reed Multiplexer	Yes	No	Yes	Yes	Yes	Yes	Yes	Yes	Yes
34925A FET Multiplexer (2-wire)	Yes	No	Yes	Yes	Yes	Yes	No	Yes	No
34925A FET Multiplexer (1-wire)	Yes	No	Yes	Yes	No	Yes	No	No	No

Note: See user's guide for additional information

Multiple multiplexers can connect to the built-in analog buses, allowing you to scan up to 560 2-wire channels or 640 1-wire channels in a single mainframe. The 34921A also offers 4 channels for directly measuring current. Or, if you need more current channels, shunts can be added to the terminal block for easy current measurements.

The multiplexer modules feature break-before-make connections to ensure that no two signals are connected to each other during a scan. Or, if you prefer, you can control switching manually to create your own switch configuration. All the multiplexer switches have a relay counter to help predict when relays need to be replaced.

Note: The 34923A and 34924A have 100-ohm input protection resistors that limit current and protect the reed relays.

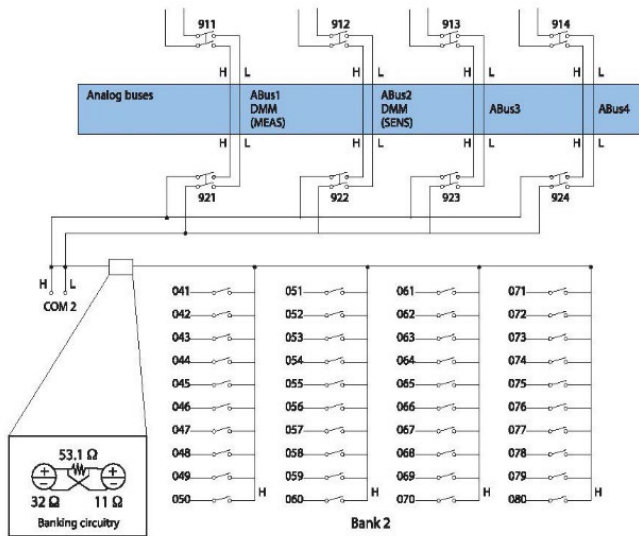

Figure 3. 34925A 40/80-channel optically isolated FET mux (shown in 1-wire mode bank 2)

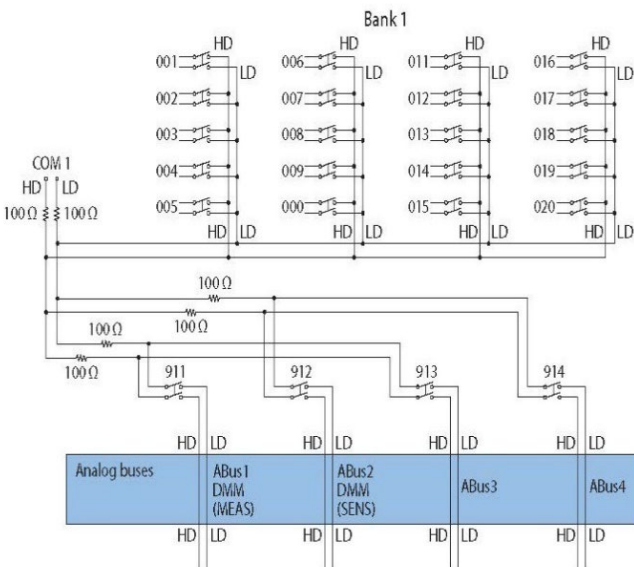

Figure 4. 34923A 40 channel reed multiplexer (bank 1 shown)

Multiplexer switch modules	34921A	34922A	34923A	34924A	34925A
Channels/configurations	40 2-wire 20 4-wire 4-current 1.5 A Fused	70 2-wire 35 4-wire	80 1-wire 40 2-wire 20 4-wire	70 2-wire 35 4-wire	80 1-wire 40 2-wire 20 4-wire
Switch type	Armature latching	Armature latching	Reed	Reed	Optically isolated FET
Input characteristics (per channel)					
Max volts	± 300 V ^{1, 13}	± 300 V ^{1, 13}	± 150 V peak ^{2, 14}	± 150 V peak ^{2, 14}	± 80 V peak ²
Max current (DC, AC RMS) Switch current	1 A	1 A	0.5 A ^{5/} 0.05 A ¹¹	0.5 A ^{5/} 0.05 A ¹¹	0.02 A ⁸
Carry current	2 A	2 A	1.5 A ^{5/} 0.05 A ¹¹	1.5 A ^{5/} 0.05 A ¹¹	
Power (VA) ⁶	60 VA	60 VA	10 VA	10 VA	1.6 VA
Volt-Hertz limit	10 ⁸	10 ⁸	10 ⁸	10 ⁸	10 ⁷
Initial closed channel res ³	< 1.5 Ω ¹²	< 1.5 Ω ¹²	< 1.5 Ω ^{5/} 200 ¹¹ nominal	< 1.5 Ω ^{5/} 200 ¹¹ Nominal	< 700 Ω ¹¹
General specifications					
Offset voltage ³	< 3 μV	< 3 μV	< 50 μV < 100 uV 1-wire	< 50 uV	< 3 μV
DC Isolation (ch-ch, ch-earth)	> 10 GΩ	> 10 GΩ	> 10 GΩ >	10 GΩ	> 10 GΩ
Leakage current ³	N/A	N/A	N/A	N/A	20 nA ⁹
T/C cold junction accuracy ^{3, 10}	< 1°C	N/A	N/A	N/A	N/A
AC characteristics					
Bandwidth at terminal block ⁴	45 MHz	25 MHz	45 MHz ^{5/} 4 MHz 10 MHz 1-wire	25 MHz ^{5/} 4 MHz ¹¹	1 MHz
Crosstalk at terminal block (ch-ch) ⁴ 300 kHz	- 75 dB	- 75 dB	- 75 dB	- 75 dB	Not recommended for RF signal switching
1 MHz	- 75 dB	- 75 dB	- 75 dB	- 70 dB	
20 MHz	- 50 dB	- 50 dB	- 50 dB	- 45 dB	
45 MHz	- 40 dB	- 50 dB	- 40 dB		
Capacitance at terminal block HI-LO	150 pF	250 pF	130 pF	200 pF	100 pF
LO – earth	150 pF	200 pF	120 pF	170 pF	300 pF (600 pF 1-wire)
General Characteristics					
Relay life, typical No-load	100 M	100 M	1000 M	1000 M	Unlimited within banks
10 V, 100 mA	10 M	10 M	10 M	10 M	
Rated load	100 k	100 k	10 k	10 k	
Scanning speeds ⁷	100 ch/sec	100 ch/sec	500 ch/sec	500 ch/sec	1000 ch/sec
Open/ close time, typical	4 ms/4 ms	4 ms/4 ms	0.5 ms/0.5 ms	0.5 ms/0.5 ms	0.25 ms/0.25 ms
Analog bus backplane	Yes	Yes	Yes	Yes	Yes
Notes:					
1. DC or AC RMS voltage, channel-to-channel or channel-to-earth					
2. Peak voltage, channel-to-channel or channel-to-earth					
3. Into analog bus. System errors are included in the internal DMM measurement accuracy specifications					
4. 50 Ω source, 50 Ω load, differential measurements verified with 4-port network analyzer (Sdd21)					
5. With input resistors bypassed. Bypassing resistors will reduce the lifetime of relays. See the rated load relay life characteristics.					
6. Limited to 6 W of channel resistance power loss per module					
7. Speeds are for 2-wire ohms or DCV, 4 1/2 digits, delay 0, display off, autozero off, and within the bank					
8. DC or peak AC current					
9. Ambient temperature < 30°C					
10. Includes 0.5°C temperature reference sensor and 0.5°C terminal block isothermal gradient error, measured under worst-case loading of the mainframe; see User's Guide for information on supported external reference sensors					
11. With input protection resistors: 2 x 100 Ω ±5%; 0.5W; TC = ±200 ppm/°C. The series resistance of the 34923/24/25 limits the use of the 100 Ω range.					
12. Channel resistance is typically < 1.5 Ω but can go as high as 50 Ω when a channel is used in measurement applications with < 10 mA load current. Increased relay channel resistance for measurements with load currents below 10 mA can occur on cards that have been out of service or following relay inactivity for periods of greater than 1 week. Switching relays for 2K cycles prior to use may reduce the variation in channel resistance. Applies to the 34921A and 34922A. Keysight recommends the use of 4-wire Ohms for resistance measurements. For high accuracy voltage measurements, select the DMM input resistance setting of >10 G ohms to minimize the impact of relay contact resistance.					
13. Pollution Degree 1 ±300Vrms or VDC; Pollution Degree 2 ±100Vrms or VDC					
14. Pollution Degree 1 ±150Vpeak; Pollution Degree 2 ±100Vpeak					

34980A Matrix Switch Modules

The 34980A matrix modules are full Crosspoint matrices that allow you to connect any row to any column. This is a convenient way to connect multiple test instruments to multiple points on a device under test.

Choose from the following features:

- Latching armature relays— Max 300 Vrms or DC, 1 A
- High-speed reed relays— Max 150 Vpeak, 0.5 A
- Configurable dual 4x8, dual 4x16, or quad 4x32 modules
- Single-wire configuration (34933A or 34934A)
- High-density matrix with automatic surge protection and row disconnects for flexible measurements (34934A)
- Analog bus expandable rows to create larger matrices
- (34931A, 32A, 33A)
- Connections via standard 50 or 78-pin D-sub cables or detachable terminal block

Each cross-point in the matrix switch has two wires—a high and a low for the measurement. Or, if you prefer, the 34933A and 34934A can be configured as a single-wire matrix, increasing the number of channels.

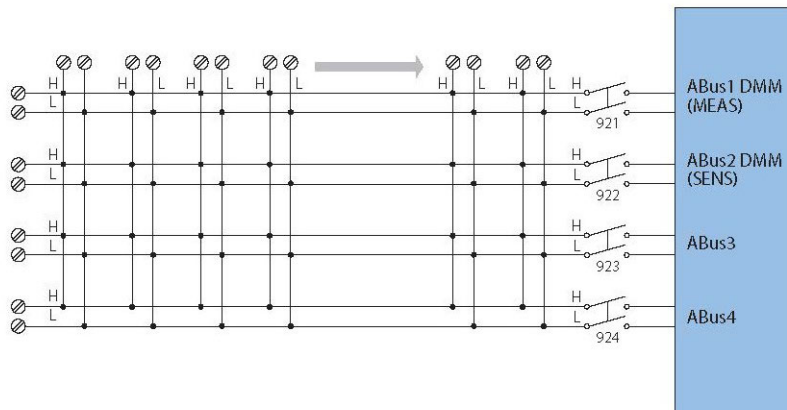

Figure 5. 34932A dual 4x16 armature matrix

The 34933A also has in-rush resistors on each column for added protection. The 34934A also has in-rush protection resistors but also has an automatic bypass switch for flexibility in making low-level measurements. Row disconnect switches also reduce the capacitance loading when combining modules to create larger matrices.

Multiple matrix modules can be combined through the analog bus or the row expansion kit (34934A only) to create a larger matrix. The matrix can then be connected to the internal DMM for easy measurements.

Combine your matrix with a multiplexer switch to achieve the desired switching topology and get a lower-cost solution with better specifications. All the matrix switches include a relay counter to help predict when relays need to be replaced. Use the sequencing feature to easily change between different cross-point setups.

NOTE: The 34933A and 34934A have 100-ohm input protection resistors to limit current and protect the reed relays.

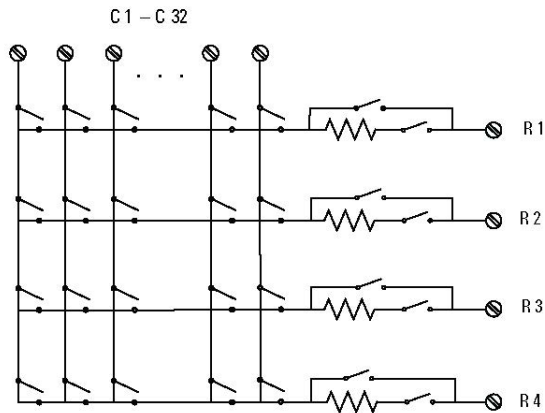

Figure 6. 34934A quad 4x32 matrix (1 of 4 matrices shown)

Matrix switch modules	34931A	34932A	34933A	34934A
Channels/configurations	dual 4x8 8x8 4x16	dual 4x16 8x16 4x32	dual 4x8 8x8 4x16 quad 4x8, 1-wire	quad 4x32 4x128 8x64 16x32
Switch type	Armature latching	Armature latching	Reed non-latching	Reed non-latching
Input characteristics (per channel)				
Max volts	± 300 V ^{1, 13}	± 300 V ^{1, 13}	± 150 V _{peak} ^{2, 14}	± 100 V _{peak}
Max current (DC, AC RMS)				
Switch current	1 A	1 A	0.5 A ⁵ /0.05 A ⁸	0.5 A
Carry current	2 A	2 A	1.5 A ⁵ /0.05 A ⁸	0.5 A
Power (VA) ⁶	60 VA	60 VA	10 VA ^{7, 8, 9}	10 VA ^{2, 8, 10}
Volt-Hertz limit	10 ⁸	10 ⁸	10 ⁸	10 ⁸
Initial closed channel res ³	< 1.5 Ω	< 1.5 Ω	< 1.5 Ω ⁵ /200 Ω ⁸ nominal	< 1Ω/100 Ω ^{8, 10}
General Specifications				
Offset voltage ³	< 3 uV	< 3 uV	< 50 uV < 100 uV 1-wire	< 20 uV < 50 uV 1-wire
DC Isolation (ch-ch, ch-earth)	> 10G Ω ¹²	> 10G Ω ¹²	> 10G Ω	10G Ω
AC characteristics				
Bandwidth at terminal block ⁴	30 MHz	30 MHz	30 MHz ⁵ /4 MHz ⁸ 2 MHz 1-wire	35 MHz 2-wire 15 MHz 1-wire
Crosstalk at terminal block (ch-ch) ⁴				
300 kHz	-65 dB	-65 dB	-65 dB	-65 dB
1 MHz	-55 dB	-55 dB	-55 dB	-55 dB
20 MHz	-30 dB	-30 dB	-40 dB	-33 dB
Capacitance at terminal block				
HI-LO	50 pF	50 pF	80 pF	45 pF
LO – earth	80 pF	80 pF	75 pF	250 pF
General characteristics				
Relay life, typical				
No-load	100 M	100 M	1000 M	1000 M operations
10 V, 100 mA	10 M	10 M	10 M	
Rated load	100 k	100 k	10 k	
Open/close time	4 ms/4 ms	4 ms/4 ms	0.5 ms/0.5 ms	0.35 ms/0.10 ms
Analog bus backplane connection	Bank 2	Bank 2	Bank 2	No

Notes:

- DC or AC RMS voltage, channel-to-channel or channel-to-earth
- Peak voltage, channel-to-channel or channel-to-earth
- Into analog bus. System errors are included in the internal DMM measurement accuracy specifications
- 50 Ω source, 50 Ω load, differential measurements verified (Sdd21)
- With input resistors bypassed. Bypassing resistors will reduce the lifetime of relays. See the rated load relay life characteristics.
- Limited to 6 W channel resistance power loss per module
- Power restrictions allow only 20 channels to be closed at one time
- Protection Resistors:
- 34933A - 100Ω ± 5%; 0.5W; TC = ±200ppm/°C.
- 34934A - 100Ω ± 1%; 0.25W; TC = ±100ppm/°C.
- If this resistance is not bypassed in the low side source line of 4-wire resistance measurement, the 100 Ω range is limited.
- Channel resistance is typically < 1.5 Ω but can go as high as 50 Ω when a channel is used in measurement applications with < 10 mA load current. Increased relay channel resistance for measurements with load currents below 10 mA can occur on cards that have been out of service or following relay inactivity for periods of greater than 1 week. Switching relays for 2K cycles prior to use may reduce the variation in channel resistance. Applies to the 34931A and 34932A. Keysight recommends the use of 4-wire Ohms for resistance measurements. For high accuracy voltage measurements, select the DMM input resistance setting of > 10 G ohms to minimize the impact of relay contact resistance.
- Pollution Degree 1 ±300Vrms or VDC; Pollution Degree 2 ±100Vrms or VDC
- Pollution Degree 1 ±150Vpeak; Pollution Degree 2 ±100Vpeak

34980A General-Purpose Switch Modules

The 34980A general-purpose switches can be used to route signals or to control other system devices. These switches are ideal for device actuation and switching loads or power supplies.

Choose from the following features:

- Form C channels up to 1 A, 60 VA
- Form A channels up to 5 A, 150 VA
- Armature latching relays
- Simultaneous channel switching
- Temperature sensor to detect overheating conditions
- Connections via standard 50 or 78-pin Dsub cables or detachable terminal block

The 34937A is the most versatile general-purpose switch with 28 Form C channels that can switch up to 1 A of current. In addition, this module has four Form A channels that can switch up to 5 A of current. For power switching applications, the 34938A has 20 5-amp channels in a Form A topology. Each Form A general-purpose switch can handle up to 150 W, enough for many power line switching applications. For high-density applications, the 34939A offers 64 Form A channels for switching up to 1A and carrying currents up to 2A.

The general purpose switches contain latching armature relays where multiple channels can be closed at the same time. Additionally, for switching reactive loads, the optional terminal blocks have pads for snubbing circuits.

The built-in relay counter helps predict when relays need to be replaced.

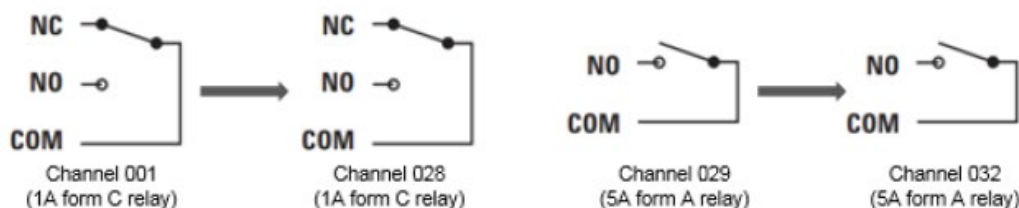

Figure 7. 34937A 32-channel Form A / Form C

General purpose switch modules	34937A	34938A	34939A
Channels/configurations	28 Form C 4 Form A	20 Form A	64 Form A
Switch Type	Armature, latching	Armature, latching	Armature, latching
Input characteristics (per channel)			
Max volts (DC, AC RMS, Peak)	Form C – 300 VAC/DC ^{1,4,7} Form A – 30 VDC/250 VAC ⁵	30 VDC/250 VAC ^{1,5}	+/- 100 V peak ⁶
Max current (DC, AC RMS, Peak)	Form C – 1 A (2 A carry) Form A – 5 A switch (7 A carry)	5 A switch (7 A carry)	1 A switch (2 A carry)
Power (VA) ²	Form C – 60 VA Form A – 150 VA	150 VA	60 VA
Volt-Hertz limit	10 ⁸	10 ⁸	10 ⁸
General specifications			
Offset voltage	3 μ V	3 μ V	3 μ V
Initial closed channel resistance ⁸	Form C – 125 m Ω Form A – 50 m Ω	< 60 m Ω	< 125 m Ω
CD isolation (ch-ch, ch-earth)	> 10 G Ω	> 10 G Ω	10 G Ω
AC characteristics			
Bandwidth at terminal block ³	10 MHz	1 MHz	10 MHz
Channel isolation at terminal block ³			
100 kHz	55 dB	60 dB	45 dB
1 MHz	35 dB	40 dB	25 dB
10 MHz	15 dB		5 dB
Capacitance at terminal block			
CH - CH	Form C 12 pF, Form A 10 pF	65 pF	20 pF
CH - earth	Form C 21 pF, Form A 18 pF	105 pF	70 pF
General characteristics			
Relay life no-load/rated	Form C – 100 M/100 k Form A – 50 M/30 k	50 M/30 k	> 100 M/100 k
Open/close time	Form C – 4 ms/4 ms Form A – 10 ms/10ms	10 ms/10ms	4 ms/4ms
Initial/reset relay state	Form C- maintain state Form A – user-configurable	User-configurable	Maintain
Analog bus backplane connection	No	No	No
Notes:			
1. DC or AC RMS voltage, channel-to-channel or channel-to-earth			
2. Limited to 6 W of channel resistance power loss per module			
3. 50 Ω source, 50 Ω load, differential measurements verified (S21)			
4. Pollution Degree 1 \pm 300Vrms or VDC; Pollution Degree 2 \pm 100Vrms or VDC			
5. Pollution Degree 1 \pm 250Vrms or VDC; Pollution Degree 2 \pm 100Vrms or VDC			
6. Peak voltage, channel-to-channel or channel-to-earth			
7. Differential Voltage FormC – FormA: Pollution Degree 1 300Vrms or Vdc Pollution Degree 2 100Vrms or VDC			
8. Channel resistance is typically < 1.5 Ω but can go as high as 50 Ω when a channel is used in measurement applications with < 10 mA load current. Increased relay channel resistance for measurements with load currents below 10 mA can occur on cards that have been out of service or following relay inactivity for periods of greater than 1 week. Switching relays for 2K cycles prior to use may reduce the variation in channel resistance. Applies to the 34937A, 34938A and 34939A			

34980A RF and Microwave Switch Modules

The 34980A offers a variety of RF and microwave switch modules—RF multiplexers, SPDT switching from DC to 26.5 GHz, or a switch/ attenuator driver module that allows you to control switches or attenuators external to the 34980A mainframe.

34941A/42A—from DC to 3 GHz

The RF switch modules can be used to switch signals from DC to 3 GHz and above. This can be useful for switching signals between oscilloscopes, spectrum analyzers, network analyzers, and other RF test equipment.

Choose from the following features:

- 50- or 75-ohm Quad 4-channel multiplexers
- DC to 3 GHz
- 30 V, 0.5 A, 10 W

The 34941A and 34942A are configured as four independent 1x4 RF multiplexers on a single module. Multiple banks can be connected together to create a larger multiplexer. To prevent ground loops, individual multiplexers are isolated from each other and from the mainframe's chassis. However, the multiplexer channels can be chassis grounded with a simple change. Both 50-ohm and 75-ohm versions are available.

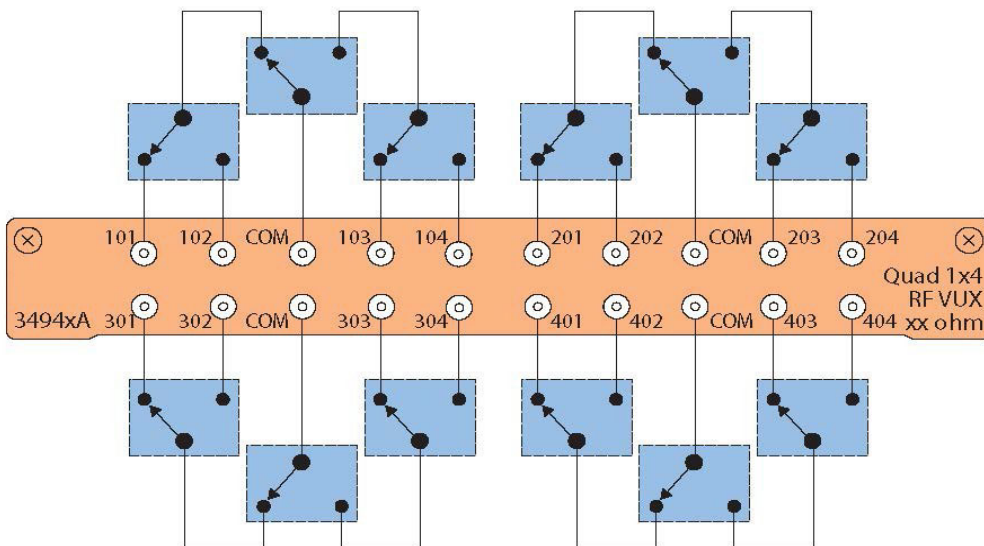

Figure 8. 34941A Quad 1x4 50 ohm 3 GHz multiplexer

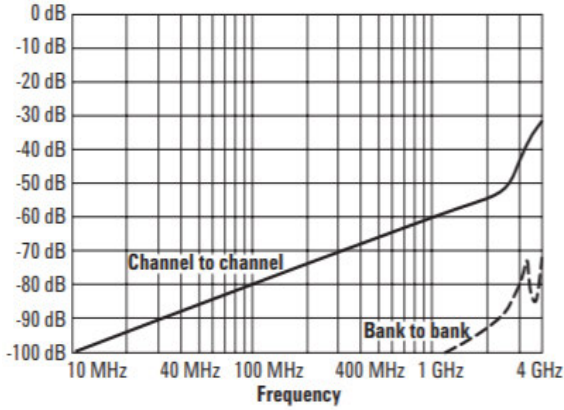

Figure 9. 34941A typical initial crosstalk

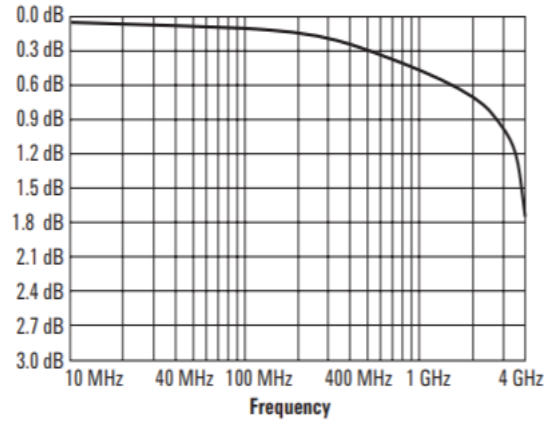

Figure 10. 34941A typical initial insertion loss

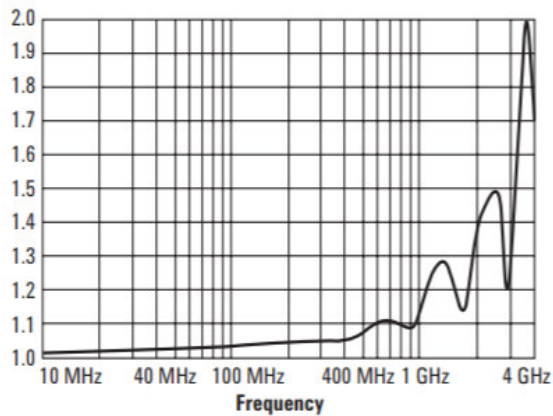

Figure 11. 34941A typical initial VSWR

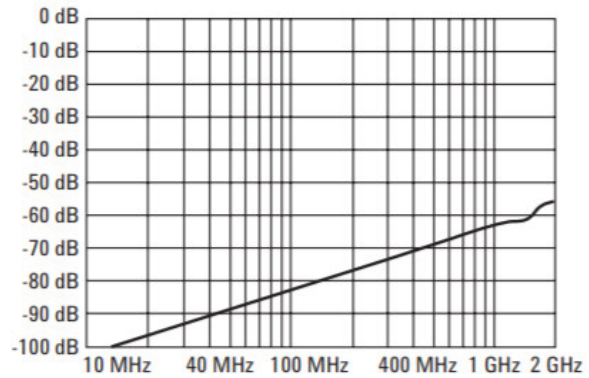

Figure 12. 34942A typical initial crosstalk

34946A/47A—From DC to 26.5 GHz

For applications where you need only a few high-frequency switches, the 34946A and 34947A offer single-pole, double-throw switches in either 4GHz, 20GHz or 26.5GHz options. These modules internally mount two or three independent Keysight N1810 series coaxial switches. These switches are well known for their excellent insertion loss, isolation, and VSWR specifications.

Switch read-back capabilities allow you to query the position of the switch. You can choose higher density with the unterminated switches or select the terminated switches to maintain an impedance match.

34946A/47A Option 001

These modules can also be ordered without switches installed. This gives you the capability to install your own N1810 series switches or use the module to control the N1810 Series switches outside the mainframe.

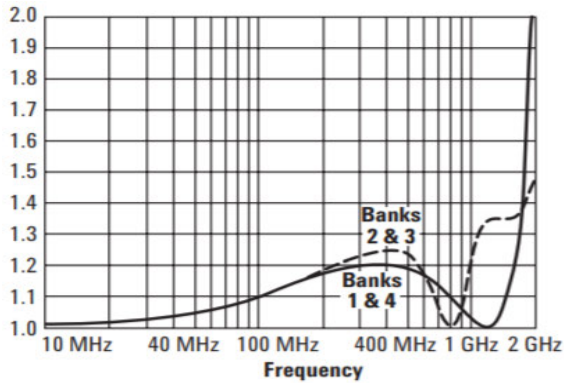

Figure 13. 34942A typical initial VSWR

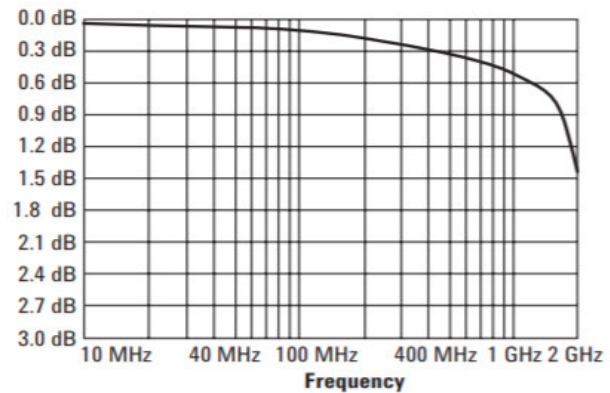

Figure 14. 34942 typical initial insertion loss

N1810 minimum required switch options	Option	Comment
Coil Voltage	option 124	24 VDC coil
DC Connector	option 201	D" subminiature 9 pin female
Drive	option 402	Position indicators

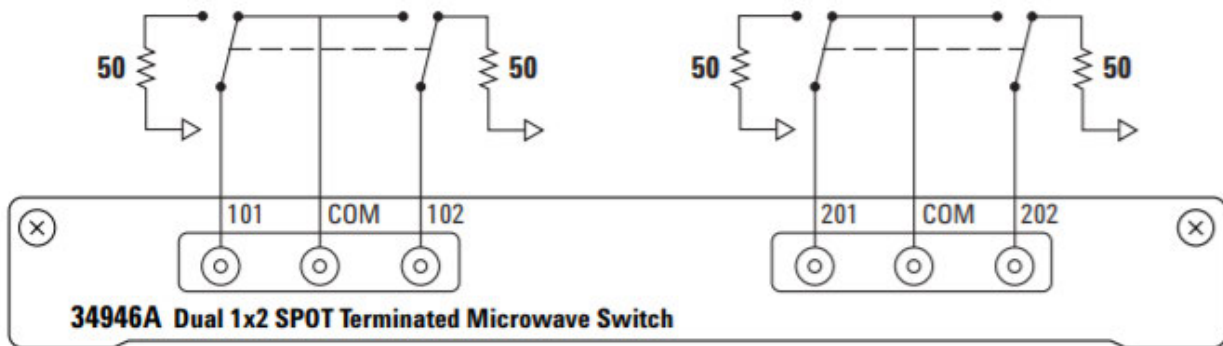

Figure 15. 34946A Dual 1x2 SPDT terminated microwave switch

	DC to 3 GHz		DC to 26.5 GHz ³	
	34941A	34942A	34946A	34947A
Channels	quad 1x4	quad 1x4	2 SPDT	3 SPDT
Switch Type	50 Ω unterminated, latching relays	75 Ω unterminated, latching relays	50 Ω terminated	50 Ω unterminated
RF characteristics				
Frequency range ²	DC to 3 GHz	DC to 1.5 GHz	DC to 4 GHz, 20 GHz or 26.5 GHz	DC to 4 GHz, 20 GHz or 26.5 GHz
Insertion loss ² < 40C/80% RH)				
100 MHz	0.15 dB	0.15 dB	DC to 4 GHz < 0.42 dB, @ 20 GHz < 0.69 dB, @ 26.5 GHz < 0.8 dB	DC to 4 GHz < 0.42 dB, @ 20 GHz < 0.69 dB, @ 26.5 GHz < 0.8 dB
1 GHz	0.60 dB	0.60 dB		
3 GHz	1.40 dB	N/A		
VSWR				
100 MHz	1.03	1.15	DC to 4 GHz < 1.15, @ 20 GHz < 1.30, @ 26.5GHz < 1.6	DC to 4 GHz < 1.15, @ 20 GHz < 1.30, @ 26.5GHz < 1.6
1 GHz	1.25	1.35		
3 GHz	1.55	N/A		
Isolation (dB) ²	Contact factory	Contact factory		
100 MHz	80 dB	80 dB	DC to 4 GHz > 85 dB, @ 20 GHz > 67 dB, @ 26.5 GHz > 60 dB	DC to 4 GHz > 85 dB, @ 20 GHz > 67 dB, @ 26.5 GHz > 60 dB
1 GHz	58 dB	60 dB		
3 GHz	40 dB	N/A		
Spurious noise below 1.3 GHz	-140 dBm	-140 dBm	80 dB	80 dB
Rise time	< 80 ps	< 160 ps	N/A	N/A
Signal delay	< 1 ns	< 1 ns	N/A	N/A
Capacitance	< 30 pF	< 30 pF	N/A	N/A
Switching characteristics				
Max volts ¹	30 V	30 V	7 VDC	7 VDC
Max current	0.5 A	0.5 A	N/A	N/A
Max power	10 W ⁵	10 W ⁵	1 W@7 VDC, 50 W peak ⁴	1 W@7 VDC, 50 W peak ⁴
Offset voltage	10 μ V	10 μ V	N/A	N/A
Initial channel resistance ⁶	1 Ω	1 Ω	N/A	N/A
Volt-Hertz limit	2 x 10 ¹⁰	2 x 10 ¹⁰		
General characteristics				
Relay life	300,000 at 30 V/10 mA load; 100,000 at 10 W load RF S _A meas	300,000 at 30 V/10 mA load; 100,000 at 10 W load RF S _A meas	> 5 M cycles	> 5 M cycles
Open/close time	18 ms/18 ms	18 ms/18 ms	< 15 ms/15 ms	< 15 ms/15 ms
Connector type	Female SMA	Mini 75 Ω SMB	Female SMA	Female SMA
Coil voltage	N/A	N/A	24 VDC	24 VDC
Analog bus backplane connection	No	No	No	No

Note:

1. Channel-to-earth
2. 50 Ω source, 50 Ω load (75 Ω for 34942A)
3. For more detailed switch specifications, see the Keysight N1810TL, N1811TL, N1812UL for 34946A, and N1810UL for the 34947A.
4. 10 μ sec maximum duration
5. Max power is 1 W between 30 MHz and 1 GHz for CISPR 11 compliance
6. Channel resistance is typically < 1.5 Ω but can go as high as 50 Ω when a channel is used in measurement applications with < 10 mA load current. Increased relay channel resistance for measurements with load currents below 10 mA can occur on cards that have been out of service or following relay inactivity for periods of greater than 1 week. Switching relays for 2K cycles prior to use may reduce the variation in channel resistance. Applies to the 34941A and 34942A.

34945A/34945EXT Microwave Switch/Attenuator Driver

This module allows you to control switches, attenuators, and other devices external to the 34980A. The 34945A / 34945EXT provides the power and control signals for many of the most popular microwave switches and attenuators. One 34945A /34945EXT combination can drive up to 64 switch coils—that's 32 standard SPDT switches. The 34945A /EXT can be extended by adding additional 34945EXT boards. The first 34945EXT is powered by the mainframe. You can add up to seven additional 34945EXT boards with user-supplied power. Multiple switch operations are performed in sequential order, or for faster, simultaneous switching, you can connect an external power supply to the 34945EXT.

The Y1150A-Y1155A distribution boards enable simple connections to the external switches. The distribution boards plug onto the 34945EXT and are used to route the power and control signals from the driver module to the switches using standard cables.

The 34945A /34945EXT also has sensing capabilities that allow a read back of the actual position of the switch or attenuator. Drive signals for LED indicators are also provided to give a visual indication of the switch position. The following microwave switches and attenuators are supported by the Y1150AY1155A distribution boards:

- N181x/U9397x series SPDT switches
- 8762/3/4 series SPDT switches (screw terminals)
- 8765x coaxial switches
- 8766x/8767x/8768x multiport switches
- 87104x/106x/L710xx/L720xx multiport switches
- 87406x series matrix switches
- 87204x/206x series multiport switches
- 87606x series matrix switches
- 87222x/L7222 transfer switches
- 849x and 8490x series attenuators
- Other switches and devices through individual screw terminal connections



Figure 16. 34945A/34945EXT

34945EXT switch drive (64 channels, low side drive mode)

General specifications	
Driver off voltage (max)	30 V
Driver off leakage current	500 μ A
Driver on current (max)	600 mA
Driver on voltage (max)	0.5 V @ 600 mA
34945EXT switch drive (64 channels, TTL drive mode)	
Hi output voltage	3 V @ I _{out} = 2 mA
Lo output voltage	0.4 V @ I _{in} = 20 mA
Lo input Current	20 mA
34945EXT position indicator sense inputs	
Channels	64
Lo input voltage (max)	0.8 V
Hi input voltage (min)	2.5 V
Input resistance	> 100 k Ω @ V _{in} \leq 5 V > 20 k Ω @ V _{in} > 5 V
Maximum input voltage	30 V
34945EXT switch drive power supply (34945EXT powered by 34945A)	
Voltage	24 V nominal (external power supply required for switches needing more than 24 V)
Current	100 mA continuous + 200 mA (15 msec pulse, 25% duty cycle)
34945EXT external power connection	
Voltage range	4.75 V to 30 V
Current limit	2 A
LED indicator (Current mode drivers)	
Channels	64
Supply voltage	5 V nominal
LED drive current	5 mA nominal, (prog 1-20 mA)
Driver compliance voltage	0.8 V
34945EXT dimensions	
Dimensions	11.2" x 4.5" x 1.5" high with distribution boards installed

Maximum of eight 34945EXT's per mainframe

Switch drive control is also available in L4445A and L4490A/91A RF Switch Platform.

Note: See Configuration Guide, "34945A, L4445A, L4490A/L4491A" literature number 5989-2272EN, for configuration details.

34980A System Control Modules

34950A 64-bit digital I/O with memory and counter

This module can be used to simulate or detect digital patterns. It has eight 8-bit digital I/O channels with handshaking, pattern memory, two 10 MHz counters with gate functions, and programmable clock output.

Digital input/output

The digital I/O bits are organized into two banks of 32-bits. The I/O bits can be configured and programmed as inputs or outputs in 8-bit channels. The digital outputs can be configured as active drive or open-drain outputs with a 10 k Ω pull up. User-supplied pull-up resistors for up to 5 V outputs are also acceptable. The digital inputs have programmable thresholds up to 5 V for compatibility with most digital logic standards.

The onboard pattern memory can be used to select and output digital stimulus or bit-stream patterns or to capture external digital data. Each bank has independent memory and directional control so that one bank can output data while the other captures data. The memory can be divided up to 64 Kbytes per 8-bit channel.

Specifically, the digital I/O channels also have:

- Variable active high drive output from 1.65 V to 5 V or open-drain
- Variable input thresholds from 0 V to 5 V
- Configurable handshaking protocols, including synchronous and strobe
- Programmable polarity
- Source or sink up to 24 mA with an I_{max} of 400 mA per module.
- Internal alarming for maskable pattern match
- 1 hardware pattern interrupt per bank
- Connections via standard 78-pin Dsub cables or detachable terminal block

Frequency counter/totalizer

The two channels can be used to count digital events, frequency, period, duty cycle, totalize, and pulse width. The counter/totalizer also includes:

- Programmable gate functionality
- Programmable input thresholds levels 0 V to 3 V

34950A 64 bit I/O

Digital input/output characteristics	
Number of channels	Eight 8 bits. Input or output, non-isolated
V_{in}	0 V – 5 V ¹
V_{out}	1.65 V – 5 V ^{1,2}
I_{out}	(max) 24 mA ²
Frequency (max)	10 MHz ³
I_{load} (max)	400 mA
$t_{rise} + t_{fall}$ (typ)	6 ns ⁵
Handshake lines	
V_{in}	0 V – 5 V
V_{out}	1.65 V – 5 V ^{2,4}
I_{out} (max)	24 mA ²
Frequency (max)	10 MHz
Counter function characteristics	
Max frequency	10 MHz (max) 50% duty cycle
V_{in}	0 V to 5 V
Min rise/fall time	5 μ sec
Totalizer function characteristics	
Maximum count	$2^{32}-1$ (4,294,967,296)
Maximum input frequency	10 MHz (max), rising or falling edge, programmable
V_{in}	0 V – 5 V
Gate input	0 V – 5 V
Maximum input frequency	5 μ sec
System clock generator characteristics	
Frequency	20 MHz – 10 Hz, configurable divide by-n 24-bits, programmable on/off
V_{out}	1.65 V – 5 V ²
I_{out} (max)	24 mA ²
Accuracy	100 ppm

Note:

1. Configurable by 8-bit channel
2. Lower current drive at lower voltages
3. From memory with handshaking
4. Configurable by bank
5. 5V, 50 pF load

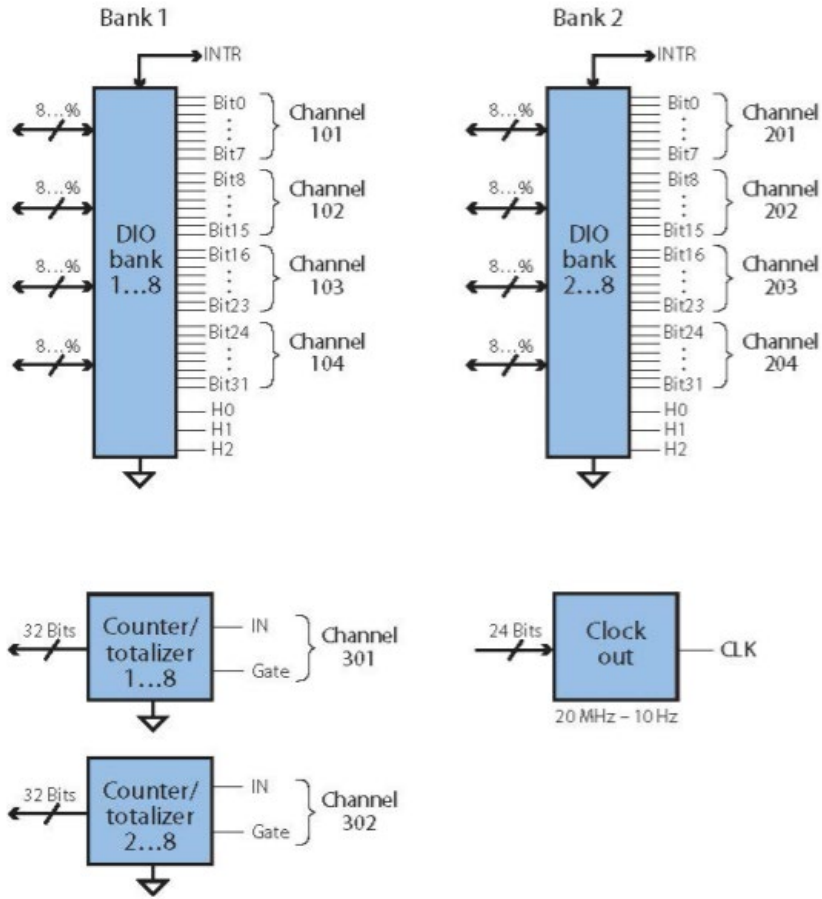

Figure 17. 34950A 64-channel digital I/O

34951A 4-Channel Isolated D/A Converter with Waveform Memory

This module has four independent, isolated channels that output DC voltage up to ± 16 V or DC current up to ± 20 mA. The gain and offset can be adjusted on-the-fly.

Each channel can be controlled manually or use the onboard memory to download a waveform. The 500k of memory is global and can store up to 32 waveforms. Any waveform can be dynamically allocated among one or more channels and output as a point-to-point arbitrary waveform generator at up to 200k points/sec. You can use the standard sine square or ramp wave shapes provided or define your own wave shape using over 500k points and output to a device under test. There is also a single CLK that can be divided down for each channel independently. The calibration command connects the D/A converters to the internal DMM to be automatically calibrated. Connections to the module can be made via standard 50-pin Dsub, cables, or a detachable terminal block.

34951A 4 channel D/A

General specifications	
Maximum update rate	200 kHz point-to-point
Monotonic	To 16 bits
Isolation	> 80 VDC/AC peak (chan-to-chassis or chan-to-chan)
Synchronization	Software commands or external trigger
Internal/external CLK accuracy	100 ppm
AC accuracy	Not specified
DC voltage	
Amplitude	± 16 V up to 10 mA
Resolution	16 bits = 500 μ V
Amplitude accuracy	$\pm (0.05\% + 3.0$ mV) (90 days, Tcal ± 5 °C or Cal:MOD?: ± 5 °C)
Ripple and noise	< 2 mVrms, 20 Hz to 250 kHz into 10 k Ω load
Settling time	40 μ S (-full scale to +full scale step, single-channel, to rated accuracy)
Output impedance	< 1 Ω with the load sensed
DC current	
Range	± 20 mA
Resolution	16-bit = 630 nA
Accuracy	$\pm (0.09\% + 5.0$ μ A) (90 days, Tcal ± 5 °C or Cal:MOD?: ± 5 °C)
Ripple and noise	< 2 μ Arms, 20 Hz to 250 kHz into 250 Ω
Compliance voltage	± 12 V
Maximum open circuit voltage	< ± 22 V
Trigger input	
Input level	TTL compatible (3.3 V logic, 5 V tolerant)
Slope	Rising or falling, selectable
Pulse width	> 100 ns
Input impedance	> 10 k Ω , DC coupled

Trigger output	
Level	TTL compatible into 1 k Ω (3.3 V logic)
Output impedance	50 Ω typical
Clock input	
Input level	TTL compatible into 1 k Ω (3.3 V logic)
Input impedance	50 Ω typical
Maximum rate	10 MHz
Clock output	
Level	TTL compatible into 1 k Ω (3.3 V logic)
Output impedance	50 Ω typical
Maximum rate	10 MHz
Accuracy	\pm 100 ppm

34952A Multifunction Module with 32-bit DIO, 2-Channel D/A and Totalizer

The multifunction module offers the flexibility you need for system control. The 34952A has four 8-bit digital I/O channels, a 100 kHz gated totalizer, and two ± 12 V analog outputs—all on a single earth-referenced module. The digital inputs and totalizer input may be included in a scan list. Alarm limits for the digital and totalizer inputs are evaluated continuously, capturing and logging alarm conditions even between scans. Connections can be made via standard 50-pin Dsub cables or detachable terminal blocks. The 34952T terminal block has a pinout for connection to an external Opto 22 board.

34952A multifunction module

Digital input/output characteristics	
Channels	Four 8-bit channels, 8 bits wide, input or output, non-isolated
Vin(L)	< 0.8 V (TTL)
Vin(H)	> 2.0 V (TTL)
Vout(L)	< 0.8 V @ Iout = -400 mA per output
Vout(H)	> 2.4 V @ Iout = 1 mA
Vin(H) max	< 42 VDC with external open drain pull-up
Alarm	Maskable pattern match or state change
Speed	4 ms (max) alarm sampling
Latency	5 ms (typical) to 34980A alarm output
Read/write speed	95/s
Totalize input characteristics	
Max count	$2^{26}-1$
Totalize input	100 kHz (max) rising or falling edge, programmable
Signal level	1 Vp-p (min) 42 Vpk (max)
Threshold	0 V or TTL
Gate input	TTL-Hi, TTL-Lo, or none
Count reset	Manual or read + reset
Read speed	85 rds/s
Analog output characteristics	
DAC 1,2	± 12 V, non-isolated
Resolution	1 mV
IOUT	10 mA max
Settling time	1 ms to 0.01% of output
Accuracy	\pm (% of output + mV)
1 year	(0.25% + 20 mV)
Temp. coefficient	\pm (0.015% + 1 mV)/°C

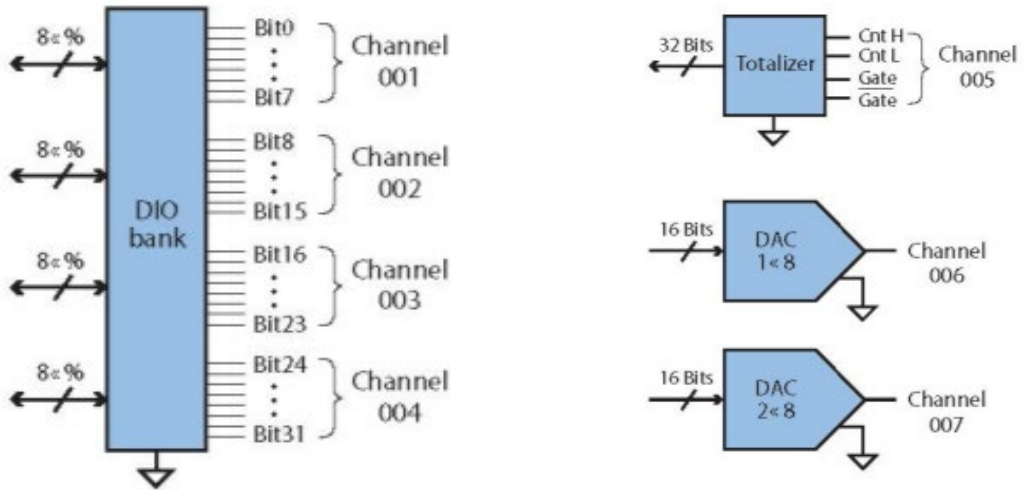

Figure 18. 34952A multifunction module

34959A Breadboard Component Module

Use this module to create your own custom designs inside the 34980A mainframe. You can control your custom circuits with access to both the +12 V and +5 V supplies, 28 relay drive lines, and two 8-bit GPIO ports. Your design can be isolated from the analog buses or connected by loading the backplane switches. Simply mount your custom PC board or other components into the space provided and connect via the two ribbon connectors provided. The module is provided with two 50- or 78-pin Dsub connector openings. For custom connections, use the detachable flat faceplates for easy modification. You can program your circuitry using standard read and write commands in SCPI.

34959A breadboard component module

General specifications	
Max module power dissipation	6 W of channel resistance
Power available:	
12 V regulation no load to full load	10%
5 V regulation no load to full load	5%
Max power from 12 V	6 W
Max power from 5V	1 W
Relay drives	
Channels	28, sink up to 100 mA
Max Input Voltage	42 VDC
Leakage Current	8 μ A
GPIO ports	
Chan 1 and Chan 2	8 configure bits as input or output
Chan 3	3 output bits
High input	2 V min, 5.5 V max
Low input	0 V min, 0.8 V max
High output	2.4 V @ 4 mA, 3 V @ 500 μ A
Low output	0.4 V @ 8 mA

34959A breadboard component module conditions of acceptability:

1. Follow local laws and regulations provided by the Authority Having Jurisdictions (AHJ). This equipment is Certified as a component for use in other CSA Certified equipment where the suitability of the combination is to be determined in the end use application.
2. When interconnecting the 34959A component module to the system components during installation, the overall 34980A and all installed modules for the system and their maximum rated allowable inputs default to the lowest rating of any one system component or module.
3. With *hazardous voltages anywhere in the overall 34980A and all installed modules use only female D-Sub output connectors Keysight Part Number DB-50(F) 1253-5854 or DB-78(F) 1253-5007.

4. With only *non-hazardous voltages in the overall 34980A and all installed modules use either female D-Sub output connectors Keysight Part Number DB-50(F) 1253-5854 or DB-78(F) 1253-5007, or male D-Sub output connectors Keysight Part Number DB-50(M) 1253-5853 or DB-78(M) 1253-6006.
5. Install overcurrent protection with devices rated or the snubber circuits to limit the current according to the 34959A Current Limiting Graph located in the User's Guide.
6. Install only Keysight supplied relays 0490-1954 when connecting to the Analog Bus.

*Any voltages greater than 30Vrms, 42.4 Vpeak and 60Vdc are considered hazardous (IEC 61010-1).

Available space for internal board/components: 5.4 x 7.5 x either 0.9 inches in height without PC board or 0.7 inches high with a PC board.

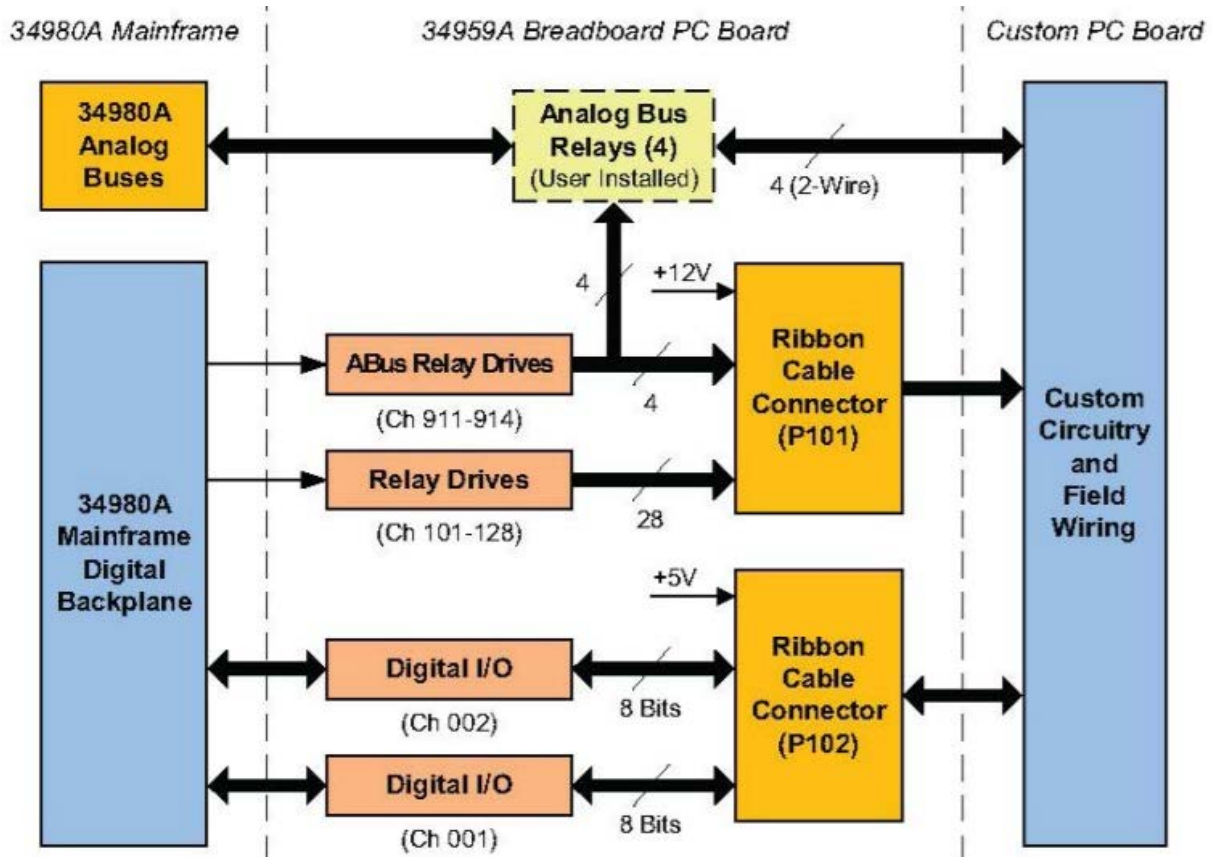

Figure 19. 34959A breadboard component module

34980A System Specifications and Characteristics

DMM accuracy \pm (% of reading + % of range)

Includes measurement error, switching error, and transducer conversion error ¹.

Range ⁴ , Frequency, etc.	24 hour ^{2,3} Tcal \pm 1°C	90 days Tcal \pm 5°C	1 year Tcal \pm 5°C	Temperature coefficient/ ^o C >Tcal \pm 5°C
DC voltage (with 34921A / 22A / 31A / 32A)^{10,11} Input impedance = Hi-Z 10 V range and below				
100.0000 mV	0.0030 + 0.0035	0.0040 + 0.0040	0.0050 + 0.0040	0.0005 + 0.0005
1.000000 V	0.0020 + 0.0006	0.0030 + 0.0007	0.0040 + 0.0007	0.0005 + 0.0001
10.00000 V	0.0015 + 0.0004	0.0020 + 0.0005	0.0035 + 0.0005	0.0005 + 0.0001
100.0000 V	0.003 + 0.0006	0.0045 + 0.0006	0.0055 + 0.0006	0.0005 + 0.0001
300.0000 V	0.003 + 0.0020	0.0045 + 0.0030	0.0055 + 0.0030	0.0005 + 0.0003
True RMS AC voltage ⁵ All ranges from 100.0000 mV to 100.0000 V				
3 Hz-5 Hz	1.00 + 0.03	1.00 + 0.04	1.00 + 0.04	0.100 + 0.004
5 Hz-10 Hz	0.35 + 0.03	0.35 + 0.04	0.35 + 0.04	0.035 + 0.004
10 Hz-20 kHz	0.04 + 0.03	0.05 + 0.04	0.06 + 0.04	0.005 + 0.004
20 kHz-50 kHz	0.10 + 0.05	0.11 + 0.05	0.12 + 0.05	0.011 + 0.005
50 kHz-100 kHz	0.55 + 0.08	0.60 + 0.08	0.60 + 0.08	0.060 + 0.008
100 kHz-300 kHz ⁶	4.00 + 0.50	4.00 + 0.50	4.00 + 0.50	0.20 + 0.02
True RMS AC voltage ⁵ 300.0000 V range				
3 Hz-5 Hz	1.00 + 0.05	1.00 + 0.08	1.00 + 0.08	0.100 + 0.008
5 Hz-10 Hz	0.35 + 0.05	0.35 + 0.08	0.35 + 0.08	0.035 + 0.008
10 Hz-20 kHz	0.04 + 0.05	0.05 + 0.08	0.06 + 0.08	0.005 + 0.008
20 kHz-50 kHz	0.10 + 0.10	0.11 + 0.12	0.12 + 0.12	0.011 + 0.012
50 kHz-100 kHz	0.55 + 0.20	0.60 + 0.20	0.60 + 0.20	0.060 + 0.020
100 kHz-300 kHz ⁶	4.00 + 1.25	4.00 + 1.25	4.00 + 1.25	0.20 + 0.05
Resistance ⁷				
100.0000 Ω , 1 mA	0.0030 + 0.0035	0.008 + 0.004	0.010 + 0.004	
1.000000 k Ω , 1 mA	0.0020 + 0.0006	0.008 + 0.001	0.010 + 0.001	0.0006 + 0.0005 0.0006 +
10.00000 k Ω , 100 μ A	0.0020 + 0.0005	0.008 + 0.001	0.010 + 0.001	0.0001 0.0006 + 0.0001
100.0000 k Ω , 10 μ A	0.0020 + 0.0005	0.008 + 0.001	0.010 + 0.001	0.0006 + 0.0001 0.0010 +
1.000000 M Ω , 5.0 μ A	0.002 + 0.001	0.008 + 0.001	0.010 + 0.001	0.0002 0.0030 + 0.0004
10.00000 M Ω , 500 nA	0.015 + 0.001	0.020 + 0.001	0.040 + 0.001	0.1500 + 0.0002
100.0000 M Ω , 500 nA / 10 M Ω	0.300 + 0.010	0.800 + 0.010	0.800 + 0.010	
Frequency and period ⁸				
100 mV to 300V range:				
3 Hz-5 Hz	0.10	0.10	0.10	0.005
5 Hz-10 Hz	0.05	0.05	0.05	0.005
10 Hz-40 Hz	0.03	0.03	0.03	0.001
40 Hz-300 kHz	0.006	0.01	0.01	0.001
DC current (34921A only)				
10.00000 mA, < 0.1V, burden typ	0.005 + 0.010 0.010 +	0.030 + 0.020 0.030 +	0.050 + 0.020 0.050 +	0.002 + 0.0020 0.002 +
100.0000 mA, < 0.6V	0.004 0.050 + 0.006	0.005 0.080 + 0.010	0.005 0.100 + 0.010	0.0005 0.005 + 0.0010
1.000000 A, < 2 V				
True RMS AC current (34921A only)				
10.00000 mA and ⁵ 1.0 A				
3 Hz-5 Hz	1.00 + 0.04	1.00 + 0.04	1.00 + 0.04	0.100 + 0.006
5 Hz-10 Hz	0.30 + 0.04	0.30 + 0.04	0.30 + 0.04	0.035 + 0.006
10 Hz-5 kHz	0.10 + 0.04	0.10 + 0.04	0.10 + 0.04	0.015 + 0.006
100.0000 mA ⁹				
3 Hz-5 Hz	1.00 + 0.5	1.00 + 0.5	1.00 + 0.5	0.100 + 0.006
5 Hz-10 Hz	0.30 + 0.5	0.30 + 0.5	0.30 + 0.5	0.035 + 0.006
10 Hz-5 kHz	0.10 + 0.5	0.10 + 0.5	0.10 + 0.5	0.015 + 0.006

Note:

1. One hour warm-up and a fixed configuration with slow AC filter, sine wave input, and 6½ digits. Temperature within ± 5°C of temperature at calibration (Tcal between 18-28°C)
2. 90 minute warm-up and a fixed configuration and 6½ digits. Temperature within ± 1°C of temperature at calibration (Tcal between 18-28°C)
3. Relative to calibration standards
4. 20% over range on all ranges except 300VDC and AC ranges and 1 ADC and AC current ranges
5. For sine wave input > 5% of range; for inputs from 1% to 5% of range and < 50 kHz add 0.1% of range additional error; for AC filter slow
6. For sine wave input >5% of range, limited to 1 x 10⁸ volt-hertz. Typically, 30% of reading error at 1 MHz.
7. Accuracy for 4-wire ohms. Add 4 ohms uncertainty (typical) for 2-wire ohms function due to conductor and contact resistance variability in the DMM. The 2-wire resistance accuracy can be improved by measuring a short on each channel and using the built-in y = Mx + b scaling function. See User Guide, Chapter 3. The series resistance of the 34923/24/25/33/34 limits the use of the 100 ohms resistance range. Keysight recommends the use of 4-wire ohms for resistance measurements. For high accuracy voltage measurements, select the DMM input resistance setting of > 10 G ohms to minimize the impact of relay contact resistance.
8. For inputs >100 mV; for inputs 10 mV to 100 mV multiply % of reading error X 10; for 1 sec aperture (6 1/2 digits)
9. Specified only for inputs > 10 mA. For AC filter slow
10. Add 50 uV error for 34923A/24A/33A and 7 uV error for the 34925A
11. Voltage measurements using Fixed-Z input impedance for the 100 V and 300 V ranges.

Additional low frequency error for ACV, ACI (% of reading)

Frequency	AC Filter Slow	AC Filter Medium	AC Filter Fast
10 Hz – 20 Hz	0	0.74	-
20 Hz – 40 Hz	0	0.22	-
40 Hz – 100 Hz	0	0.06	0.73
100 Hz -200 Hz	0	0.01	0.22
200 Hz – 1 kHz	0	0	0.18
> 1 kHz	0	0	0

Additional error for frequency, Period (% of reading)

Frequency	Aperture (Digits)		
	1 second (6½ digits)	seconds (5½ digits)	0.01 seconds (4½ digits)
3 Hz – 5 Hz	0	0.12	0.12
5 Hz – 10 Hz	0	0.17	0.17
10 Hz – 40 Hz	0	0.2	0.2
40 Hz – 100 Hz	0	0.06	0.21
100 Hz – 300 Hz	0	0.03	0.21
300 Hz – 1 kHz	0	0.01	0.07
> 1 kHz	0	0	0.02

Temperature measurement accuracy

Temperature 1-year accuracy	Type	Best Range ¹		Extended Range ¹		Temperature coefficient/°C
Thermocouple (34921A only, includes cold junction accuracy on terminal block)	B	1100 °C to 1820 °C	1.2 °C	400 °C to 1100 °C	1.8 °C	0.03 °C
	E	-150 °C to 1000 °C	1.0 °C	-200 °C to -150 °C	1.5 °C	0.03 °C
	J	-150 °C to 1200 °C	1.0 °C	-210 °C to -150 °C	1.2 °C	0.03 °C
	K	-100 °C to 1200 °C	1.0 °C	-200 °C to -100 °C	1.5 °C	0.03 °C
	N	-100 °C to 1300 °C	1.0 °C	-200 °C to -100 °C	1.5 °C	0.03 °C
	R	300 °C to 1760 °C	1.2 °C	-50 °C to 300 °C	1.8 °C	0.03 °C
	S	400 °C to 1760 °C	1.2 °C	-50 °C to 400 °C	1.8 °C	0.03 °C
	T	-100 °C to 400 °C	1.0 °C	-200 °C to -100 °C	1.5 °C	0.03 °C
RTD	R ₀ from 49 Ω to 2.1 kΩ	-200 °C to 600 °C	0.06 °C			0.003 °C
Thermistor	2.2k, 5k, 10k	-80 °C to 150 °C	0.08 °C			0.002 °C

Note:

1. For total measurement accuracy, add temperature probe error, for < 1 °C accuracy, an external fixed reference is required.

Typical System Speeds (measurements made on a 3.2GHz PC running VB6 in Windows XP Pro)

Single channel reading times in msec	Direct measurements – direct to I/O (includes switch, measure time and I/O time)			Direct measurement to memory(GPIB)
Single-channel ^{1,2}	GPIB msec	USB 2.0 msec	LAN (w/VXI 11) msec	Measurement into memory msec
Single channel, DCV	2.83	3.14	4.57	1.90
Single channel, ACV	5.00	5.35	5.75	4.00
Single channel, ohms	2.91	3.14	4.65	1.90
Single channel while changing scale (eg MEAS DCV 10 / MEAS DCV 1)	9.52	10.64	11.76	8.40
Single channel while changing function (eg. MEAS ACV / MEAS DCV)	128	120	120	120
Command execution time ³				
34925A	Open or Close	0.7	0.9	1.6
	Read?	2.9	3.3	4.7
	Close/Read/Open	4.8	5.3	6.5
	Init/*WAI	1.9	2.1	3
	Close/Init/Open	3.7	4.1	4.7
34923A	Open or Close	0.9	1.2	1.8
	Read?	2.9	3.3	4.7
	Close/Read/Open	5.3	5.8	6.5
	Init/*WAI	1.9	2.1	3
	Close/Init/Open	4.2	4.7	5.2
34921A	Open or Close	4.7	5.3	5.3
	Read?	2.9	3	4.7
	Close/Read/Open	14	15	15
	Init/*WAI	1.9	2.1	3
	Close/Init/Open	12.4	14	4
34934A	Close	1.8	2.2	3.1
	Read?	2.8	3.1	4.8
	Open	1.5	1.8	3.2

Note:

1. Readings were made with minimum NPLC, delay 0, display off, autozero off
2. All times include the issue of "READ?" and the retrieval of data
3. CLOSE or OPEN bus transfer times allowed to overlap previous command; command parse times overlap current activity until IO latency dominant

34934A multi-channel close speeds over GPIB (msec)

	Isolate for fixed mode	Auto 100 mode	Auto 0 mode
Close 2 channels	0.97	1.22	1.31
Close 5 channels	0.43	0.54	0.56
Close 10 channels	0.22	0.28	0.29
Close 60 channels	0.13	0.17	0.21

Single channel measurement rates – DMM reading rates ^{1,2}

Function	Resolution	Rds/s
DCV	4½ digits (0.02 plc)	3000
	5½ digits (1 plc)	59
	6½ digits (10 plc)	6
2-wire resistance	4½ digits (0.02 plc)	2000
	5½ digits (1 plc)	58
	6½ digits (10 plc)	6
Thermocouple	(0.02 plc)	1000
	0.1 °C (1 plc)	59
RTD/Thermistor	1°C (0.02 plc)	1900
	0.1 °C (1 plc)	58
	0.01 °C (10 plc)	6
ACV	6½ fast (200Hz)	350
	6½ med (20Hz)	350
	6½ slow (3Hz)	350
Frequency, period	4½ digits (10 ms)	70
	5½ digits (100 ms)	9
	6½ digits (1 s gate)	1

Note:

1. Readings speeds for 60Hz; autozero off
2. For fixed function and range, readings to memory, scaling and alarms off, autozero off.

Scanning measurement rates to bus or memory

Scanning channels ¹	Direct measurements – direct to I/O (includes switch, measure time and I/O time)			Measurement into memory
	GPIB ch/sec	USB 2.0 ch/sec	LAN (w VXI 11) ch/sec	Into memory ch/sec
Scanning DCV or 2-wire ohms				
34925A	920	860	980	1000
34923A/24A	588	572	605	625
34921A/22A	109	109	109	109
Scanning ACV ²				
34925A	318	315	323	318
34923A/24A	260	260	260	260
34921A/22A	88	88	88	88
Scanning temperature				
34921A	109	109	109	109
Scanning digital in 34950A	660	592	815	1038

Note:

- Speeds are for 4 1/2 digits, delay 0, display off, autozero off and scanning is within bank on the same module; add 10ms for between banks or modules for 2-wire measurements; 4-wire measurements are slower
- Add additional time for filter setting on ACV

Data out of memory to LAN, USB, or GPIB (data transfer rate with 1000 channel blocks)

	GPIB rds/sec	USB 2.0 rds/sec	LAN (w VXI 11) ¹ rds/sec
Readings	2560	2400	3542
Readings with timestamp	1304	1230	1826
Readings with all format options ON	980	926	1361

Note:

- LAN large block throughput rate is increased by approximately 30% using LAN sockets

Measurement Characteristics with Optional Internal DMM

Measurement characteristics

DC voltage	
Measurement method	Continuously integrating multi-slope III A-D converter
A-D linearity	0.0002% of reading + 0.0001% of range on 10 V range
Input resistance 100 mV, 1 V, 10 V ranges 100 V, 300 V ranges	Selectable 10 M Ω or > 10,000 M Ω 10 M Ω \pm 1%
Input bias current	< 50 pA at 25 °C
Input protection	300 V for Pollution Degree 1 and 100 V for Pollution Degree 2
True RMS AC voltage	
Measurement method	AC coupled True RMS—measures the AC component of the input with up to 300 VDC for Pollution Degree 1 and 100 VDC for Pollution Degree 2 of bias on any range
Crest factor	Maximum of 5:1 at full scale
Additional crest factor errors (non-sinewave)	Crest factor 1-2 0.05% of reading Crest factor 2-3 0.15% of reading Crest factor 3-4 0.30% of reading Crest factor 4-5 0.40% of reading
AC filter bandwidth: Slow Medium Fast	3 Hz - 300 kHz 20 Hz - 300 kHz 200 Hz - 300 kHz
Input impedance	1 M Ω \pm 2% in parallel with 150 pF
Input protection	Pollution Degree 1: 300 Vrms all ranges Pollution Degree 2: 100 Vrms all ranges
Resistance	
Measurement method	Selectable 4-wire or 2-wire ohms
Current source	Referenced to LO input
Offset compensation	Selectable on 100 Ω , 1k Ω , 10 k Ω ranges
Maximum lead resistance	10% of range per lead for 100 Ω and 1k Ω ranges. 1k Ω on all other ranges
Input protection	300 V for Pollution Degree 1 and 100 for Pollution Degree 2
Frequency and period	
Measurement method	Reciprocal counting technique
Voltage ranges	Same as AC voltage function
Gate time	1 s, 100 ms, or 10 ms
Measurement timeout	Selectable 3 Hz, 20 Hz, 200 Hz LF limit
Measurement consideration (frequency and period): All frequency counters are susceptible to error when measuring low-voltage, low-frequency signals. Shielding inputs from external noise pickup is critical for minimizing measurement errors.	
DC current	
Shunt resistance	5 Ω for 10 mA, 100 mA; 0.1 Ω for 1 A

Input protection	1.5 A 250 Vac fuse on 34921A module
True RMS AC current	
Measurement method	Direct-coupled to the fuse and shunt. AC coupled True RMS measurement (measures the ac component only)
Shunt resistance	5 Ω for 10 mA; 0.1 Ω for 100 mA, 1 A
Input protection	1.5 A 250 Vac, 50/60 Hz fuse on 34921A module
Thermocouple	
Conversion	ITS-90 software compensation
Reference junction type	Internal, fixed, or external
Open thermocouple check	Selectable per channel. Open > 5 k Ω
Thermistor	44004, 44007, 44006 series
RTD	a = 0.00385 (DIN) and a = 0.00392
Measurement noise rejection 60/50 Hz¹	
DC CMRR	140 dB
AC CMMR	70 dB
Integration time Normal mode rejection²	
200 plc/3.33 s (4 s)	105 dB ³
100 plc/1.67 s (2 s)	100 dB ³
20 plc/333 ms (400 ms)	95 dB ³
10 plc/167 ms (200 ms)	90 dB ³
2 plc/33.3 ms (40 ms)	85 dB
1 plc/16.7 ms (20 ms)	60 dB
< 1 plc	0 dB
Note:	
1. For 1 k Ω unbalance in LO lead	
2. For power line frequency \pm 0.08%	
3. For power line frequency \pm 1% use 75 dB or \pm 2.5% use 60 dB	

DC operating characteristics⁴

Function	Digits ⁵	Readings / s	Additional RMS noise error
DCV ⁷ , DCI, and Resistance (≤10 kΩ)	6½	0.6 (0.5)	0% of range
	6½	6 (5)	0% of range
	5½	60 (50)	0.001% of range
	5½	300	0.001% of range ⁶
	4½	600	0.01% of range ⁶
	4½	3000	0.1% of range ⁶

Autozero OFF operation

Following instrument warm-up at calibration temperature ± 1 °C and < 10 minutes, add 0.0002% range additional error. +5 µV. (For 300 VDC, instead of .0002% of range, need .00066% of range)

Settling considerations

Reading settling times are affected by source impedance, low dielectric absorption characteristics, and input signal changes.

AC operating characteristics ⁸	Digits ⁹	Readings /	AC Filter
ACV, ACI:	6½	7 sec/reading	Slow (3 Hz)
	6½	1	Medium (20Hz)
	6½	8 ¹⁰	Fast (200 Hz)
	6½	100 ¹¹	Fast (200 Hz)

Note:

1. Reading speeds for 60 Hz and (50 Hz) operation; autozero OFF
2. 6½ digits = 22 bits; 5½ digits = 18 bits; 4½ digits = 15 bits
3. Add 20 µV for DCV, 4 µA for DCI, or 20 mΩ for resistance
4. For 300 VDC, multiply the additional noise error by 3.3
5. Maximum reading rates for 0.01% of AC step additional error; additional settling delay required when input DC level varies
6. 6½ digits = 22 bits; 5½ digits = 18 bits; 4½ digits = 15 bits
7. For external trigger or remote operation using default settling delay (Delay Auto)
8. Maximum limit with default settling delays defeated

General Specifications

System specifications

Scanning inputs	
Analog:	34921A, 34922A, 34923A, 34924A, and 34925A multiplexer channels
Digital	34950A/52A digital in and totalize
Scan triggering	
Source	Interval, external, button press software, or on monitor channel alarm
Scan count	1 to 50,000 or continuous
Scan Interval	0 0 99 hours; t ms step size
Channel delay	0 to 60 seconds per channel; 1 ms step size
External trig delay	< 2 ms. With monitor on < 200 ms
External trig jitter	< 2 ms
Alarms	
Analog inputs	Hi, Lo, or Hi + Lo evaluated each scan
Digital inputs	34950A/52A digital in maskable pattern match or state change 34950A/52A frequency and totalize: Hi limit only
Monitor channel	Alarm evaluated each reading
Alarm outputs	4 TTL compatible. Selectable TTL logic Hi or Lo on fail
Latency	5 ms (typical)
Memory	
Type	Volatile
Readings	500,000 with timestamp, readable during scan
States	5 instrument states with user label
Alarm queue	Up to 20 events with channel number, reading, and timestamp
System features	
Per-channel	Individual Mx+B scaling and calculated real-time min/max/average
Power fail recovery	Save switch states
Relay maintenance	Counts each relay closure and stores on module. User resettable
Real-time clock	Battery-backed, 20-year typical life
Line power	
Power supply	Universal 100 Vac to 240 Vac
Power line frequency	50 – 60 Hz ± 10% automatically sensed
Power consumption	150 VA
Environment	
Operating environment	<ul style="list-style-type: none"> 0 - 55°C, 2000 m, maximum humidity is 80% RH at 40°C and decreases linearly to 37% RH at 55°C ² IEC 60664-1 pollution degree 1 or 2 Refer to 34980A User's Guide, Chapter 4, Module Considerations section for the details of Environmental Operating Limits (current and power dissipation) for the Plug-In Modules in Pollution degree 1 or 2 environments.
Storage environment	- 40 °C to 70 °C ¹

Note:

1. Storage at temperatures above 40 °C will decrease battery life
2. From 40°C to 55°C, the maximum % Relative Humidity follows the line of constant dew point.

Mechanical

Mainframe dimensions	133 H x 426 W x 341 D mm (5.25" x 16.8" x 14") Full rack, 3 units high
Mainframe weight	8.8 kg (19.6 lbs)
Module dimensions	Approximately 170 W x 270 D x 27 H mm (6.69" x 10.62" x 1.06")
Module weights	0.73 to 1.18 kg (1.6 to 2.6 lbs)
Terminal block dimensions	170 W x 165 [or 105] D x 25 H mm (6.69" x 6.49" [or 4.13"] x 0.98")
Terminal block weights	0.27 to 0.36 kg (0.6 to 0.8 lbs)

Regulatory

Safety and EMC	Refer to Declaration of Conformity for the latest revisions of regulatory compliance at: www.keysight.com/go/conformity
----------------	---

Recommended software

- Keysight IO Libraries Suite 2019 or greater: www.keysight.com/find/IOLibraries
- BenchVue: www.keysight.com/find/benchvue
- BenchVue DAQ: www.keysight.com/find/benchvuedaq

The BenchVue platform is a prerequisite for the BenchVue DAQ application.

Software driver support for programming languages

Software drivers	IVI-C and IVI COM for Windows 7/8.1/10 and LabVIEW
------------------	--

Compatible programming tools and environments

- Keysight VEE Pro
- National Instruments Test Stand, Measurement Studio, Lab Windows/CVI, LabVIEW, Switch Executive
- Microsoft Visual Studio.NET, C/C++, Visual Basic

Keysight BenchVue Data Acquisition Control and Analysis Application system requirements

Operating system	<ul style="list-style-type: none">• Microsoft Windows 10: 32-bit & 64-bit (Professional, Enterprise, Education, Home versions).• Microsoft Windows 8 & 8.1: 32-bit & 64-bit (Professional, Enterprise, Core).• Microsoft Windows 7: SP1 and later 32-bit & 64-bit (Professional, Enterprise, Ultimate, Home Basic, Home Premium)
Processor	1 GHz or faster (2 GHz or greater recommended)
RAM	RAM: 1 GB (32-bit) or 2 GB (64-bit) (3 GB or greater recommended)
Display	1280x1024 minimum for single instrument view (higher resolution recommended for multiple instrument view)

Computer Interfaces

LXI	10/100Base-T Ethernet (Sockets, VXI-11 protocol, Web user interface)
USB	Standard USB 2.0
GPIB	IEEE-488
Language	SCPI-1999, IEEE-488.2

Definitions for Specifications

Specifications describe the warranted performance of calibrated instruments that have been stored for a minimum of 2 hours within the operating temperature range of 0 °C to 55 °C, unless otherwise stated, and after a 45-minute warm-up period. Data represented in this document are specifications unless otherwise noted.

Characteristics describe product performance that is useful in the application of the product but that is not covered by the product warranty. Characteristics are often referred to as Typical or Nominal values.

- Typically describes the characteristic performance, which 80% of instruments will meet when operated over a 20 °C to 30 °C temperature range. Typical performance is not warranted.
- Nominal describes representative performance that is useful in the application of the product when operated over a 20 °C to 30 °C temperature range. Nominal performance is not warranted.

Note: All graphs contain measured data from several units at room temperature unless otherwise noted.

Ordering Instructions

Mainframe – holds up to 8 plug-in modules

Mainframe	Description	Remarks
34980A	Multifunction data acquisition mainframe	Comes standard with “DMM” option and BenchVue DAQ
BV0006B	BenchVue Data Acquisition Control and Analysis (DAQ)	BenchVue makes it simple to connect, control instruments, and automate test sequences. Supported plug-in modules: 34921A, 34922A, 34923A, 34924A, 34925A, 34931A, 34932A, 34933A, 34937A, 34938A, 34952A.

Module	Description	Connectors	Optional terminal blocks, cables, connector kits
Multiplexer modules			
34921A	40-channel armature multiplexer w/low thermal offset (Order 34921T for temp reference)	2 – 50-pin Dsub, Male	3492xT Terminal block with screw connectors Y1135A – 1.5 m 50-pin M/F Dsub cable Y1136A – 3 m 50-pin M/F Dsub cable Y1139A – 50-pin female solder cup connector kit
34923A	40/80-channel reed multiplexer		
34925A	40/80-channel optically isolated FET multiplexer		
34922A	70-channel armature multiplexer	2 – 78-pin Dsub, Male	3492xT Terminal block, option 001 for solder connections, option 002 for screw connectors Y1137A – 1.5 m 78-pin M/F Dsub cable Y1138A – 3 m 78-pin M/F Dsub cable Y1140A – 78-pin female solder cup connector kit
34924A	70-channel reed multiplexer		
Matrix modules			
34931A	Dual 4x8 armature matrix	2 – 50-pin Dsub, Male	3493xT Terminal block with screw connectors Y1135A – 1.5 m 50-pin M/F Dsub cable Y1136A – 3 m 50-pin M/F Dsub cable Y1139A – 50-pin female solder cup connector kit
34932A	Dual 4x16 armature matrix		
34933A	Dual/Quad 4x8 reed matrix		
34934A	Quad 4x32 reed matrix	2 – 78-pin Dsub, Male	34934T Terminal block with screw connectors OR 34934C Configuration block Y1137A – 1.5 m 78-pin M/F Dsub cable Y1138A – 3 m 78-pin M/F Dsub cable Y1140A – 78-pin female solder cup connector kit
General-purpose/actuator modules			
34937A	32-channel Form C/Form A general-purpose switch	2 – 50-pin Dsub, Male	3493xT Terminal block with screw connectors Y1135A – 1.5 m 50-pin M/F Dsub cable Y1136A – 3 m 50-pin M/F Dsub cable Y1139A – 50-pin female solder cup connector kit
34938A	20-channel 5-amp Form A switch		
34939A	64-channel Form A Switch	2 – 78-pin Dsub, Male	34939T Terminal block with screw connectors Y1137A – 1.5 m 78-pin M/F Dsub cable Y1138A – 3 m 78-pin M/F Dsub cable Y1140A – 78-pin female solder cup connector kit
RF and microwave modules			
34941A	Quad 1x4 50-ohm 3-GHz RF multiplexer	20 - SMA	Requires standard 50 ohm SMA RF cables, and optional 8710-2576 SMA Extender wrench for connecting SMA connectors
34942A	Quad 1x4 75-ohm 1.5 GHz RF multiplexer	20 – mini SMB	Requires mini 75-ohm SMB RF cables, adapters
34945A	Microwave switch/attenuator driver	N/A	Requires 34945EXT and optional Y1150A-Y1155A distribution boards (one 34945EXT is automatically included in each 34945A order)
34946A	Dual 1x2 SPDT terminated microwave switch Option 001: No switches installed Option 004: 4 GHz switches installed Option 020: 20 GHz switches installed Option 026: 26.5 GHz switches installed	6 SMA	Requires standard 50 ohm SMA cables and adapters 8710-2576 SMA Extender for connecting SMA connectors. Option 001 supports qty 2 of any of the following switches: N1810UL unterminated SPDT N1810TL terminated SPDT N1811TL terminated 4 port transfer N1812UL unterminated 5 port transfer
34947A		9 SMA	Requires standard 50 ohm SMA cables and adapters 8710-2576 SMA Extender for connecting SMA connectors. Option 001 supports qty 3 N1810UL unterminated SPDT switches

System measurement and control modules

34950A	64-bit digital I/O with memory and counter	2 – 78-pin Dsub, Female	3495xT Terminal block with screw connectors Y1134A – Row expansion cables Y1137A – 1.5 m 78-pin M/F Dsub cable Y1138A – 3 m 78-pin M/F Dsub cable Y1142A – 78-pin male solder cup connector kit
34951A	4-channel isolated D/A converter with waveform memory (DMM option required for calibration)	1 – 50-pin Dsub, Female	3495xT Terminal block with screw connectors Y1135A – 1.5 m 50-pin M/F Dsub cable Y1136A – 3 m 50-pin M/F Dsub cable Y1141A – 50-pin male solder cup connector kit
34952A	Multifunction module with 32-bit DIO, 2-ch D/A, and totalizer		
34959A	Breadboard component module	26- & 40-pin internal ribbon cable connectors	Any terminal block can be used assuming 50- or 78-pin Dsub is used ¹

Accessories

Y1130B	Rackmount kit for 34980A, forward or reverse mount (must order either E3663AC rail kit for forward rack mounting or E3664AC rail kit for reverse rack mounting)
Y1131A	Verification and diagnostic tools for 34980A mainframe and modules (select option for specific module support)
Y1132A	Module extender for 34980A. Extends cable to locate module outside of mainframe 8710-2576 SMA Extender for connecting SMA connectors.

Terminal blocks used for discrete wiring. Supports 20 AWG wires for 100 connections

3492xT	Multiplexer terminal blocks
3493xT	Matrix and GP terminal blocks
3495xT	Measurement and control terminal blocks

Screw terminal block

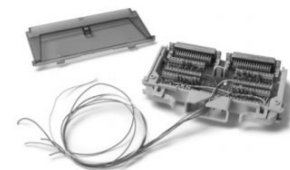

Cables - used for direct cable connection to the module. Some modules require 2 cables

Y1134A	Row expansion cables for 34934C and 34934T – 30Vrms, 60Vdc, 3A Max, no transients.
Y1135A	1.5 m 50-pin Dsub, M/F twisted pair with outer shield cable – 300 V, 3A, 1000Vpk transients Max
Y1136A	3 m 50-pin Dsub, M/F twisted pair with outer shield cable – 300 V, 3A, 1000Vpk transients Max
Y1137A	1.5 m 78-pin Dsub, M/F twisted pair with outer shield cable – 300 V, 1A, 750Vpk transients Max
Y1138A	3 m 78-pin Dsub, M/F twisted pair with outer shield cable – 300 V, 1A, 750Vpk transients Max

Connector kits used to build custom cables

Y1139A	Solder cup connector kit for 34921/23/25/31/32/33/37/38 – 50-pin Dsub female – 125 V, 7A Max
Y1140A	Solder cup connector kit for 34922, 34924 – 78-pin Dsub female – 60 V, 3A Max
Y1141A	Solder cup connector kit for 34951, 34952 – 50-pin Dsub male – 125 V, 5A, no transients
Y1142A	Solder cup connector kit for the 34950A – 78-pin Dsub male – 60 V, 5A, no transients.

Connector kit



1. Refer to the list of Conditions of Acceptability to determine suitability of the combination. See page 33 for more information.

Accessories

34945A accessory distribution boards are required for control of external switches. One 34945EXT is required for each 64 coils (included, add more 34945EXTs for additional coils).

34945EXT	External driver for 34945A, one required for each 64 coils –holds 4 distribution boards. Order Y1157A-Y1159A cable kits to connect from distribution boards to switches and attenuators
Y1150A	34945EXT distribution board for 8 N181x SPDT switches
Y1151A	34945EXT distribution board for two 87104x/106x L7x0xx multiport or 87406B matrix switches
Y1152A	34945EXT distribution board for one 87204x/206x or 87606B switch and two N181x switches
Y1153A	34945EXT distribution board for two 84904/5/6/7/8 or 8494/5/6 step attenuators
Y1154A	34945EXT distribution board for two 87222, L7222C transfer switches and six N181x SPDT switches
Y1155A	34945EXT distribution board w/ generic screw terminals for driving 16 switch coils
Y1157A	9-to-10 pin cable kit for Y1150A, Y1152A, Y1154A - supplies to build 4 cables
Y1158A	10-to-10/10-to-14 pin cable kit for Y1153A, Y1154A - supplies to build 2 cables
Y1159A	6-to-16 pin cable kit for 1150A/51A/52A/53A/54A/55A - supplies to build 2 cables

Thermocouples/thermistors

34307A	10 pack of J type thermocouples
34308A	5 pack of 10 k thermistors



Mess- und Prüftechnik. Die Experten.

**Ihr Ansprechpartner /
Your Partner:**

dataTec AG

E-Mail: info@datatec.eu

>>> www.datatec.eu



Keysight enables innovators to push the boundaries of engineering by quickly solving design, emulation, and test challenges to create the best product experiences. Start your innovation journey at www.keysight.com.

This information is subject to change without notice. © Keysight Technologies, 2019 – 2024, Published in USA, March 26, 2024, 5989-1437EN