

P/N: 29428-281

Copyright

© 2022, FLIR Systems, Inc.

All rights reserved worldwide. Names and marks appearing herein are either registered trademarks or trademarks of FLIR Systems and/or its subsidiaries. All other trademarks, trade names or company names referenced herein are used for identification only and are the property of their respective owners.

Document identity

Publ. No.: 29428-281

Commit: 82695

Language:

Modified: 2022-01-25

Formatted: 2022-09-05

Website

<http://www.flir.com>

Customer support

<http://support.flir.com>

Disclaimer

Specifications subject to change without further notice. Camera models and accessories subject to regional market considerations. License procedures may apply. Products described herein may be subject to US Export Regulations. Please refer to exportquestions@flir.com with any questions.



Specifications	
Model	X8581 SLS LWIR
Detector type	Strained layer superlattice (SLS)
Spectral range	7.5 μm (lower), 11.5–12.5 μm (upper)
Resolution	1280 \times 1024
Detector pitch	12 μm
Thermal sensitivity/NETD	40 mK typical
Operability	99% typical
Sensor cooling	Linear sterling cooler
Electronics	
Readout type	Snapshot
Readout modes	Asynchronous integrate while read, Asynchronous integrate then read
Synchronization modes	Sync-in, Tri-Level Sync, Sync-out
Image time stamp	Internal precision timestamp, IRIG-B AM decoder, TSPI accurate
Trigger modes	Trigger In, Record Start, Header Based
Minimum integration time	270 ns
Pixel clock	355 MHz
Frame rate (full window)	Programmable; \sim 0.5 Hz to 181 Hz
Subwindow mode	Flexible windowing down to 64 \times 4 (steps of 64 columns, 4 rows)
Dynamic range	14-bit
On-camera image storage	<ul style="list-style-type: none"> RAM (volatile): 16 GB RAM included SSD (non-volatile): 512 GB included (compatible with 4 TB) Data transfer: SSD to Research Studio via data streaming buses
Radiometric data streaming	Simultaneous Gigabit Ethernet (GigE Vision), Camera Link, CoaXPress® 1.1, dual 5 Gb links
Standard video	HDMI, SDI
Command and control	GigE, USB, RS-232, Camera Link, CXP (GenICam protocol supported over GigE or CXP)



Mess- und Prüftechnik. Die Experten.

**Ihr Ansprechpartner /
Your Partner:**

dataTec AG

E-Mail: info@datatec.eu

>>> www.datatec.eu



P/N: 29428-281

© 2022, FLIR Systems, Inc.

#29428-281; r. 82695;

Temperature measurement	
Standard temperature range	-20°C to 350°C (-4°F to 662°F)
Optional temperature range	Up to 3000°C (5432°F)
Accuracy	≤100°C/212°F: ±2°C (±1°C typical) >100°C/212°F: ±2% of reading (±1% typical)
Optics	
Camera f/Number	f/2.5
Motorized lenses	17 mm, 25 mm, 50 mm, 100 mm, 200 mm
Manual lenses	17 mm, 25 mm, 50 mm, 100 mm, 200 mm
Micro/Macro lenses	1x
Lens interface	FLIR FPO-M (4-tab bayonet, motorized)
Focus	Motorized (compatible with manual)
Filtering	4-position warm filter wheel, standard 1-inch filters
Image/Video Presentation	
Palettes	Selectable 8-bit
Automatic gain control	Manual, Linear, Plateau equalization, ROI, DDE
Overlay	Customizable (ability to toggle off)
Video modes	SDI: 720p@50/59.9, 1080p@25/29.97
Digital zoom	Auto, best fit
General	
Operating temperature range	-20°C to 50°C (-4°F to 122°F)
Power	24 VDC (< 50 W steady state)
Weight w/handle, w/o lens	6.35 kg (14 lbs)
Size (L x W x H) w/o lens or handle	249 x 157 x 147 mm (9.8 x 6.2 x 5.8 in)
Mounting	2 x ¼ in. -20, 1 x 3/8 in. -16, 4 x #10 -24 Side: 3x ¼ in. -20 (each side)
Export classification	ECCN 6A003.b.4.a
Declaration of conformity	See: https://support.flir.com/resources/DoC

Supplies & accessories:

- 4215503; Lens 7.5-12 um 100 mm f/2.5 FPO Manual Bayonet
- 4215424; Lens 7.5-12 um 17 mm f/2.5 FPO Manual Bayonet
- 4215505; Lens 7.5-12 um 200 mm f/2.5 FPO Manual Bayonet
- 4215496; Lens 7.5-12 um 25 mm f/2.5 FPO Manual Bayonet
- 4215501; Lens 7.5-12 um 50 mm f/2.5 FPO Manual Bayonet
- 4213642; Lens 7.5-12 um, 1X microscope, f/2.5 FPO Manual Bayonet
- 4227599; FLIR Science Camera Power Supply
- 4233062; Cooled Science A and X Camera Microscope Stand
- 4232535; FLIR Research Studio, Professional Edition - 1 Year Subscription (online activation)
- 4232556; FLIR Research Studio, Professional Edition - Perpetual License (online activation)
- 4232590; FLIR Research Studio, Professional Edition - Perpetual License (USB dongle)
- 4220499; FLIR Research Studio, Standard Edition - 1 Year Subscription (online activation)
- 4220500; FLIR Research Studio, Standard Edition - Perpetual License (online activation)



FLIR X8581 SLS LWIR (f/2.5)

P/N: 29428-281

© 2022, FLIR Systems, Inc.

#29428-281; r. 82695;

- 4220646; FLIR Research Studio, Standard Edition - Perpetual License (USB dongle)
- 4232591; FLIR ResearchIR to Research Studio, Professional Edition - 1 Year License Upgrade
- 4224157; FLIR Science Camera SDK
- 4216760; FLIR Science File SDK

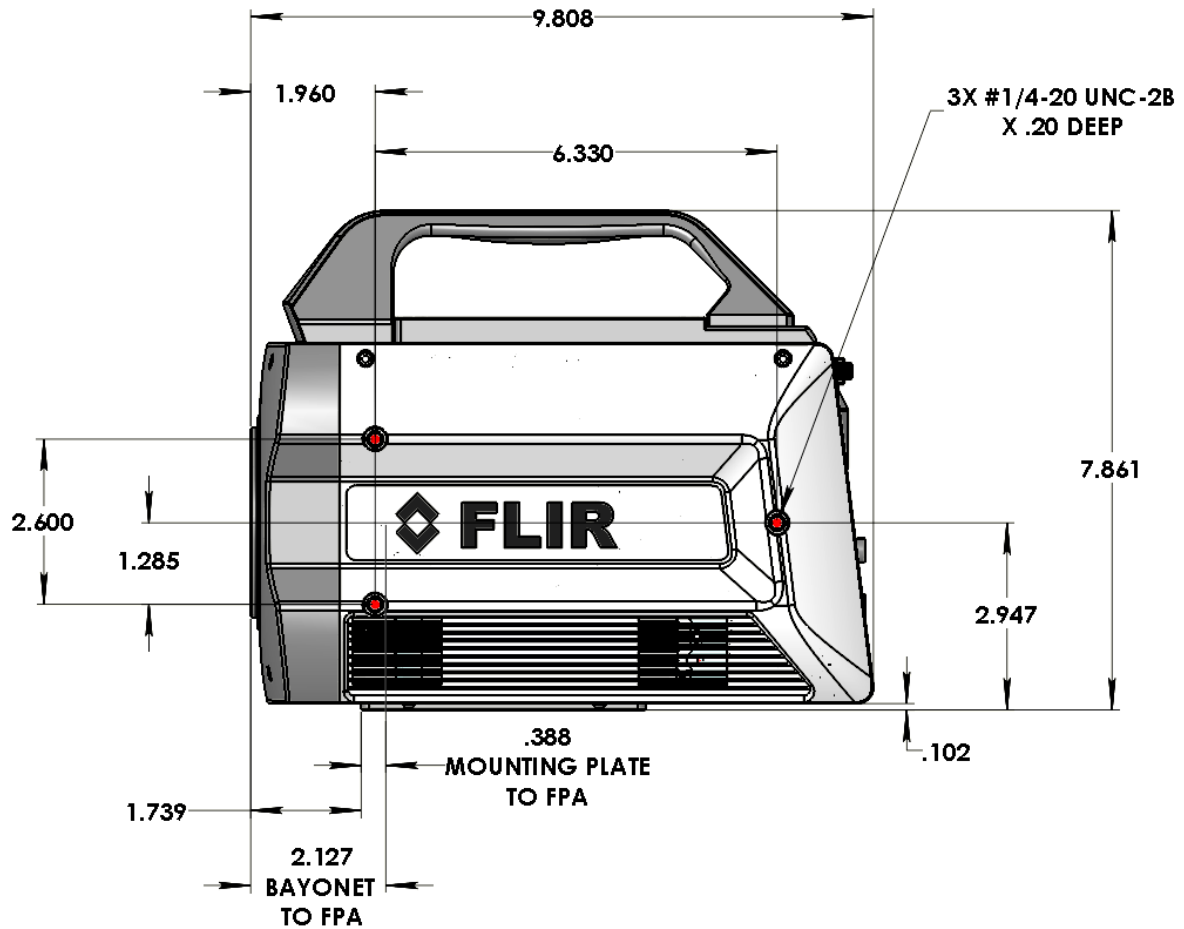

X6980 InSb in P/N Series 29267-28X

X6980 SLS in P/N Series 29421-28X

X8580 InSb in P/N Series 29422-28X

X8580 SLS in P/N Series 29428-28X

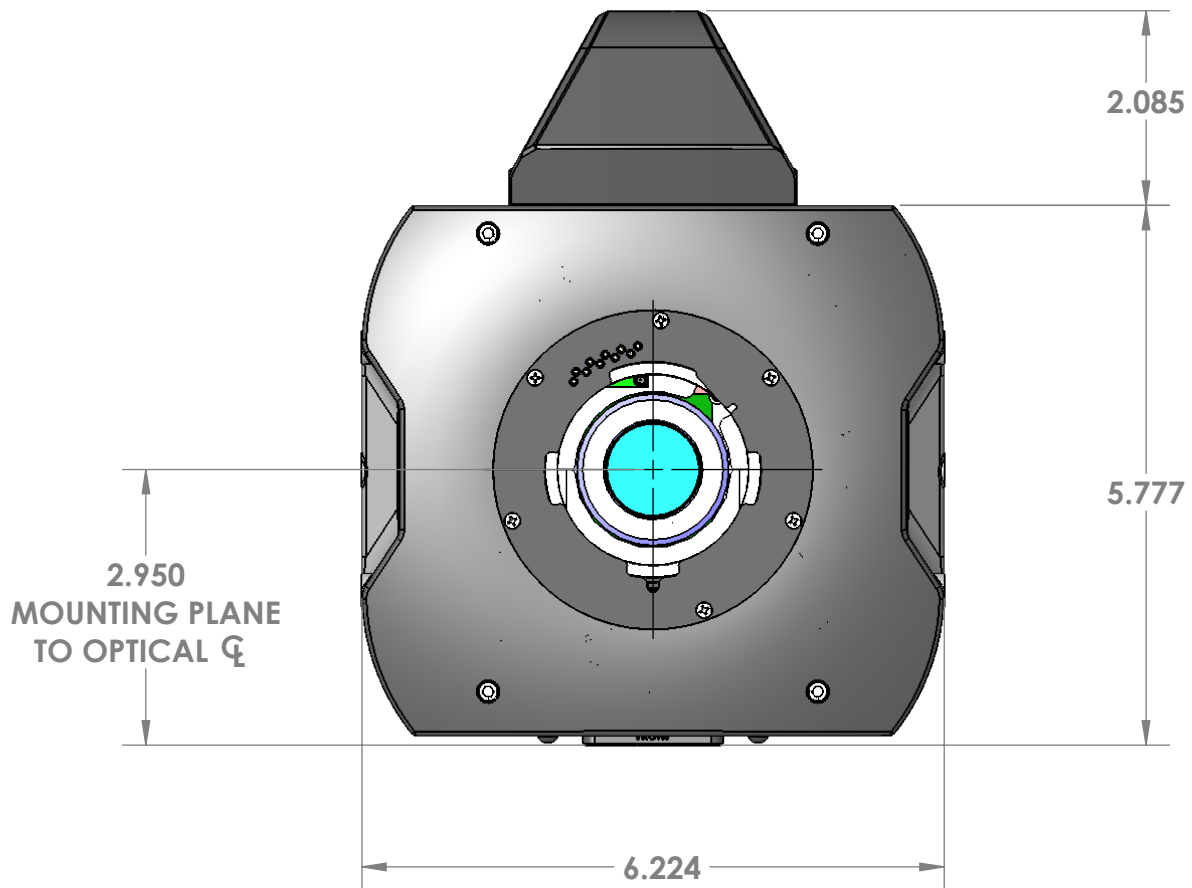

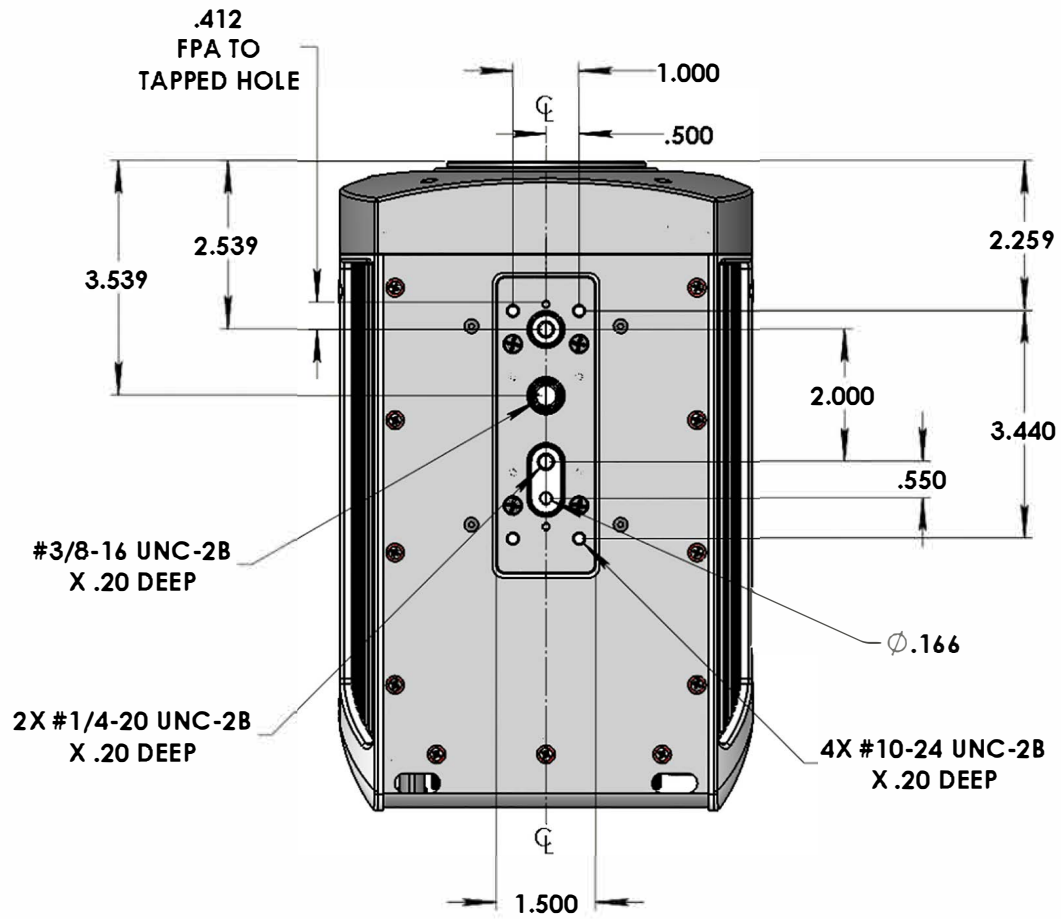

Mess- und Prüftechnik. Die Experten.

Ihr Ansprechpartner / dataTec AG
Your Partner:

E-Mail: info@datatec.eu

>>> www.datatec.eu

