

**dataTec**

**Ihr Ansprechpartner /  
Your Partner:**

**dataTec AG**

E-Mail: [info@datatec.eu](mailto:info@datatec.eu)

>>> [www.datatec.eu](http://www.datatec.eu)

EN

Mess- und Prüftechnik. Die Experten.



**Probing Solutions.  
Made in Germany.**



## HSDP Series

**High-Speed Differential Probes  
with Universal BNC Interface**

up to >4GHz,  $\pm 42V$ , 7.5m

Preliminary

Datasheet



## About HSDP Series

The HSDP series offers best-in-class performance with >2GHz models up to ±42V differential input range, and ±8V up to >4GHz bandwidth. The high input impedance, low noise, and 60V common mode voltage range the different models ideal for various in-circuit measurements for design, validation, debugging of analog signals, such as used in switched mode power supplies.

The HSDP probes series is also ideal for characterizing a wide range of serial bus designs, supporting the most popular serial bus interfaces, such as USB2.0, Ethernet (GbE), CAN/LIN, I2C, SPI, SATA, FireWire (1394b), FlexRay, HDMI etc.

The HSDP series features the industry standard 2.54mm (0.1") socketed inputs that can easily interface to a variety of connectivity options available in the market. The compact probe head design, and its variety of accessories, makes the HSDP series ideal for probing on today's smallest IC devices.

### Individual Connectivity Accessories for Highest Signal Fidelity

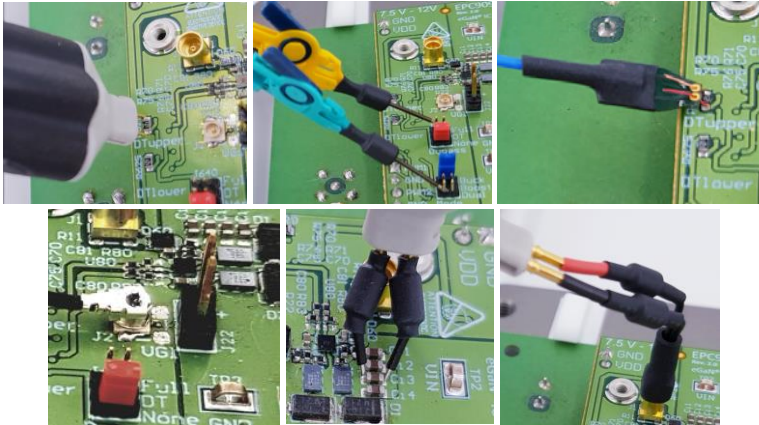

The input offset capability extends the input range of the probe. Having an input capacitance of <math><0.6\text{pF} \parallel 1\text{M}\Omega</math> between the probe tips, allows the HSDP Series to be used to probe sensitive circuits without adversely loading the circuit under test.

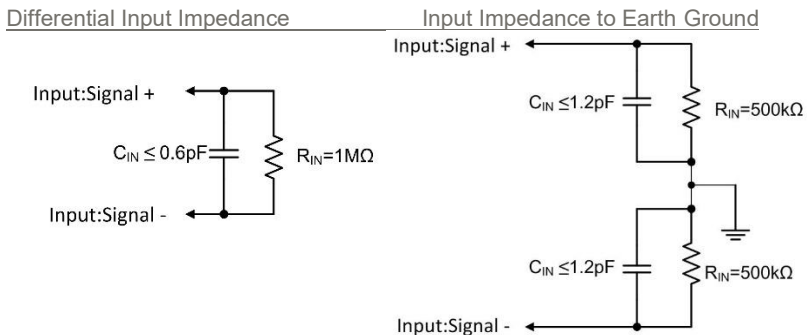

The HSDP-Series uses a PMK custom high speed FET input amplifier that provides a superior high frequency response, as well as low noise and low distortion to accurately capture the signals being measured.

All models are available with either a 7.5m or 1.3m cable length. Other lengths are available on request. The longer cable versions enable the user to probe remote, hard to reach test points that are impossible with the other probing solution in the market today.

The HSDP Series has a universal BNC output connector and is compatible with any oscilloscope with a 50Ω input impedance, or 1MΩ input impedance and a 50Ω feed-through termination, allowing the HSDP Series to be used on any oscilloscope in the lab.

HSDP-Series' DC offset can be controlled via remote control. The "PMK Probe Control" software provides the ability for the user to control the probe remotely via a computer, and provides the user with a graphical user interface. The software is free of charge, and included with PMK's 2ch and 4ch power supplies, PS2 and PS3, which are required to power the probe. The PS2 and PS3 power supplies have a USB interface as well as an optional LAN interface. The new AP-01, 1 channel battery pack power supply, provides >8h of portable and isolated operation, which allows the user the flexibility of where the probe can be used. The AP-01 supplies power only to the probe with no software remote control.

Input Voltage Range Examples

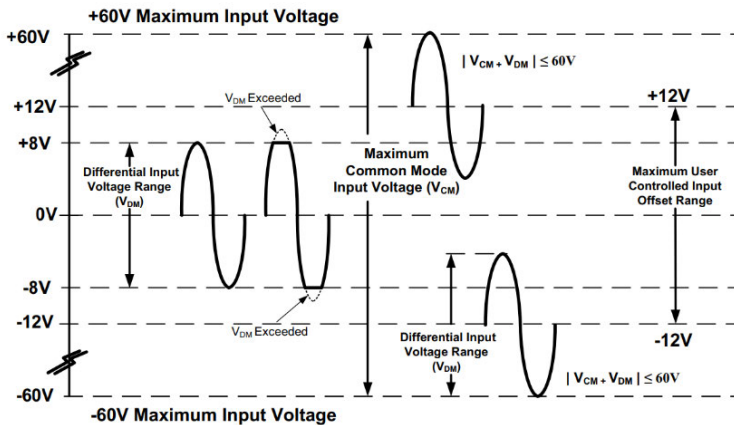

10:1 Models: HSDP4010 / HSDP2010 / HSDP2010L

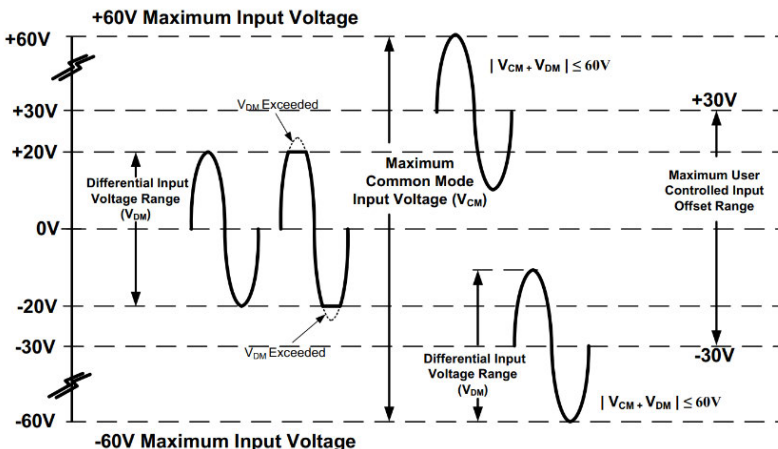

25:1 Models: HSDP2025 / HSDP2025L

## Specifications

Read the Instruction Manual before first use, and keep it for future reference. A digital copy of the latest Instruction Manual revision can be downloaded at [www.pmk.de](http://www.pmk.de)

Specifications that are not marked with (\*) as guaranteed are typical. Warm-up time is 20 minutes.

The electrical specifications are separated in multiple tables. Each specification is determined when using a PS2 power supply at +23 °C ambient temperature. This probe comes with 1 year warranty.

### Electrical Specifications

Model Number	Attenuation Ratio (± 2 % at DC)	Bandwidth (-3dB)	Differential Voltage Range (DC + AC peak) <sup>1</sup>	Differential DC Offset Range
HSDP4010	10:1	> 4 GHz 4.2 GHz (typ.)	± 8 V (16 V <sub>pp</sub> )	± 12 V
HSDP2010	10:1	> 2 GHz 2.3 GHz (typ.)	± 8 V (16 V <sub>pp</sub> )	± 12 V
HSDP2010L	10:1	> 1.8 GHz 2.0 GHz (typ.)	± 8 V (16 V <sub>pp</sub> )	± 12 V
HSDP2025	25:1	> 2 GHz 2.2 GHz (typ.)	± 20 V (40 V <sub>pp</sub> )	± 30 V
HSDP2025L	25:1	> 1.8 GHz 2.0 GHz (typ.)	± 20 V (40 V <sub>pp</sub> )	± 30 V
HSDP2050	50:1	> 2 GHz 2.2 GHz (typ.)	± 42 V (84 V <sub>pp</sub> )	± 60 V
HSDP2050M	50:1	> 1.8 GHz 2.0 GHz (typ.) <i>preliminary</i>	± 42 V (84 V <sub>pp</sub> )	± 60 V
HSDP2050L	50:1	> 1.8 GHz 2.0 GHz (typ.) <i>preliminary</i>	± 42 V (84 V <sub>pp</sub> )	± 60 V

The following specifications table is valid for all models of HSDP series. Observe the Maximum Non-Destructive Voltages between signal and GND.

<b>Common Mode Voltage Range (DC + Peak LF-AC)<sup>1</sup></b>	± 60 V
<b>Maximum Non-Destructive Voltage between signal and GND (DC + Peak LF-AC)<sup>1</sup></b>	± 60 V
<b>Differential Input Impedance</b>	1 MΩ    0.6 pF
<b>Single-ended Input Impedance</b>	500 kΩ    1.2 pF
<b>Input Coupling of the Measuring Instrument</b>	50 Ω

Notes:

<sup>1</sup> LF less than 10Hz

## Electrical Specifications (Continued)

Review also the referring derating over frequency graphs later in this document.

Model Number	Noise (Input referred) <sup>2</sup>	Rise time (10%-90%)	Propagation Delay	Common Mode Rejection Ratio (CMRR)
<b>HSDP4010</b>	< 2 mV rms 100 nV/sqrt(Hz) <i>preliminary</i>	< 140ps <i>preliminary</i>	6.7 ns	DC: > 70 dB 1 MHz: > 50 dB 10 MHz: > 45 dB 100 MHz: > 35 dB 500 MHz: > 25 dB 1 GHz: > 25 dB
<b>HSDP2010</b>	< 1.5 mV rms 50 nV/sqrt(Hz)	< 200 ps	6.7 ns	DC: > 70 dB 1 MHz: > 50 dB 10 MHz: > 45 dB 100 MHz: > 35 dB 500 MHz: > 25 dB 1 GHz: > 25 dB
<b>HSDP2010L</b>	< 2.5 mV rms 93 nV/sqrt(Hz)	< 200 ps	30.5 ns	DC: > 70 dB 1 MHz: > 50 dB 10 MHz: > 45 dB 100 MHz: > 35 dB 500 MHz: > 25 dB 1 GHz: > 25 dB
<b>HSDP2025</b>	< 3 mV rms 128 nV/sqrt(Hz)	< 200 ps	6.7 ns	DC: > 70 dB 1 MHz: > 50 dB 10 MHz: > 45 dB 100 MHz: > 35 dB 500 MHz: > 25 dB 1 GHz: > 25 dB
<b>HSDP2025L</b>	< 5 mV rms 238 nV/sqrt(Hz)	< 200 ps	30.5 ns	DC: > 70 dB 1 MHz: > 50 dB 10 MHz: > 45 dB 100 MHz: > 35 dB 500 MHz: > 25 dB 1 GHz: > 25 dB
<b>HSDP2050</b>	< 6 mV rms 250 nV/sqrt(Hz) <i>preliminary</i>	< 200 ps	6.7 ns	DC: > 70 dB 1 MHz: > 50 dB 10 MHz: > 45 dB 100 MHz: > 35 dB 500 MHz: > 25 dB 1 GHz: > 25 dB
<b>HSDP2050M</b>	< 6 mV rms 250 nV/sqrt(Hz) <i>preliminary</i>	< 200 ps	14.5 ns	DC: > 70 dB 1 MHz: > 50 dB 10 MHz: > 45 dB 100 MHz: > 35 dB 500 MHz: > 25 dB 1 GHz: > 25 dB
<b>HSDP2050L</b>	< 10 mV rms TBD nV/sqrt(Hz) <i>preliminary</i>	< 200 ps	30.5 ns	DC: > 70 dB 1 MHz: > 50 dB 10 MHz: > 45 dB 100 MHz: > 35 dB 500 MHz: > 25 dB 1 GHz: > 25 dB

Notes:

<sup>2</sup>RMS noise [mV] at 500MHz bandwidth; noise in [nV/sqrt(Hz)] at 100MHz

## Environmental Specifications

<b>Altitude</b>	operating	up to 2000 m
	non-operating	up to 15000 m
<b>Temperature Range</b>	operating	0 °C to +50 °C
	non-operating	-40 °C to +71 °C
<b>Maximum Relative Humidity</b>	operating	80 % relative humidity for temperatures up to +31 °C, decreasing linearly to 40 % at +50 °C
	non-operating	95 % relative humidity for temperatures up to +40 °C

## Probe Dimensions

The shown dimensions are in mm and [inch].

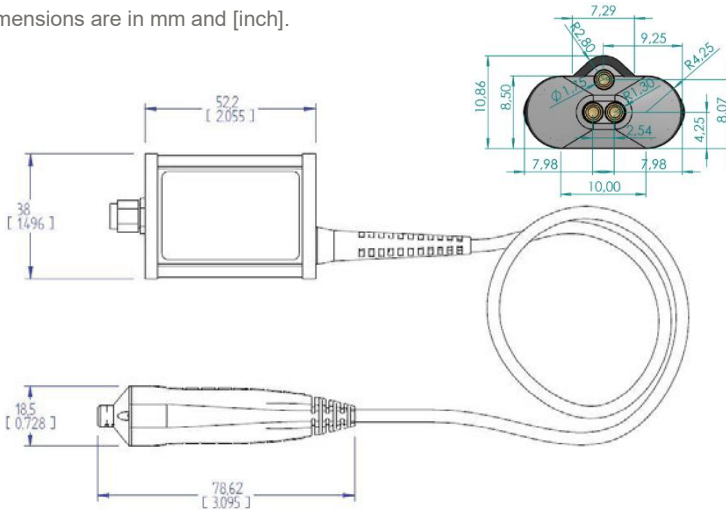

## Probe's power supply pin assignment

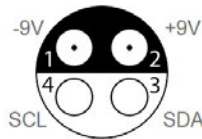

Probe's power supply pin assignment "cable view"



Observe the probe's power supply pin assignment

## Factory Calibration

Annual re-calibration is recommended. ISO17025 calibration upon delivery or as re-calibration will be possible on request.

## Typical Frequency Response

The frequency response plot shown here is for the probe series without any accessories. Frequency responses with specific accessories are available on request.

Frequency Response – HSDP Series: 2 GHz models

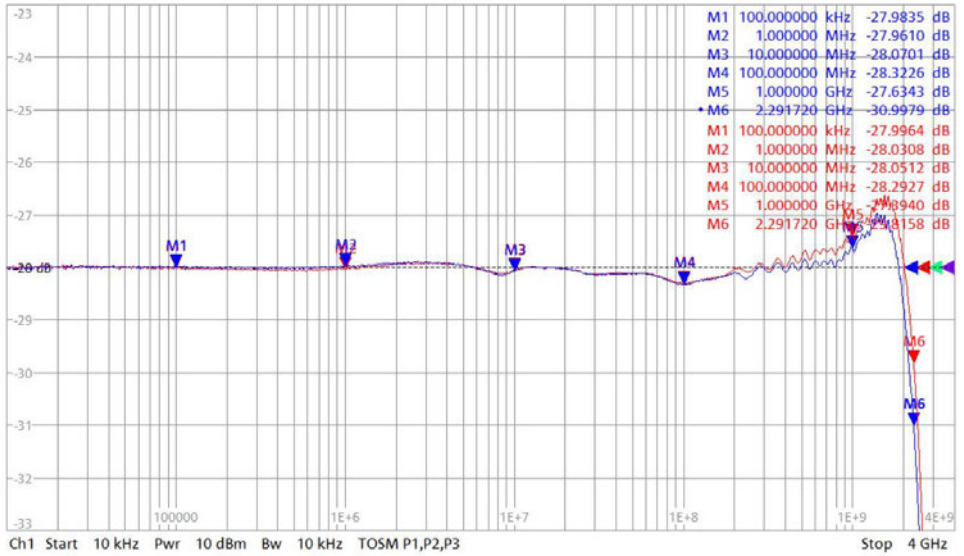

Frequency Response – HSDP Series: 4 GHz models

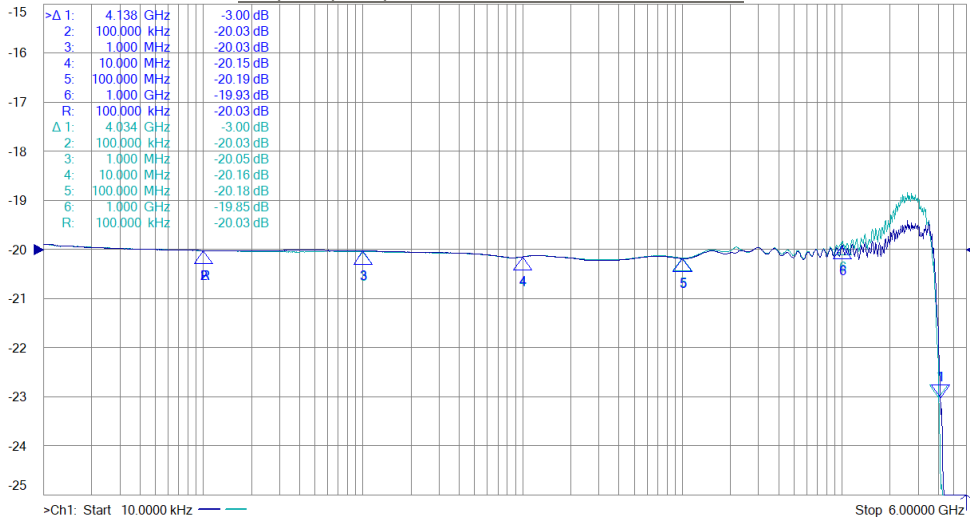

## Typical Differential Input Impedance



The input impedance of the probe decreases as the frequency of the applied signal increases.

Typical Differential Input Impedance - HSDP Series

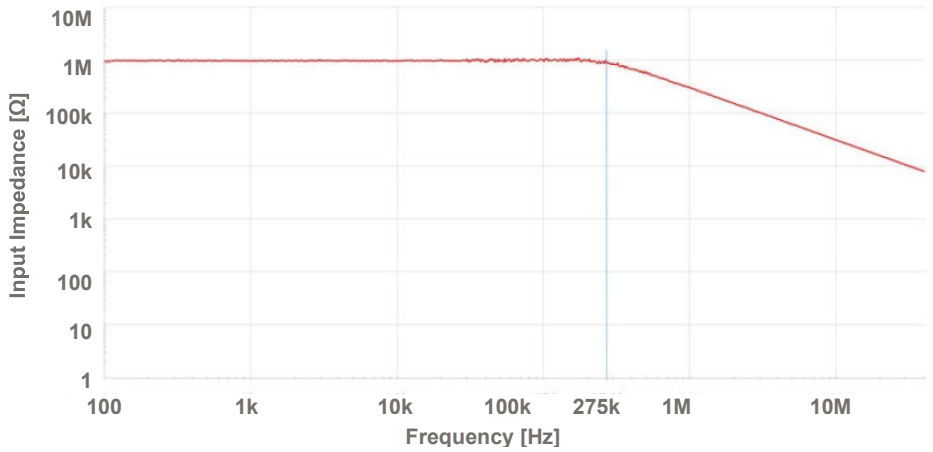

## Typical Input Voltages



Note that the maximum input voltage rating of the probe decreases as the frequency of the applied signal increases.

Input Voltage - HSDP2010 / HSDP2010L / HSDP4010

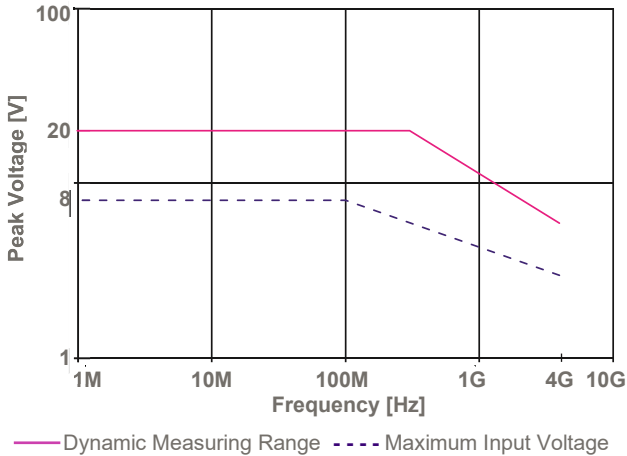



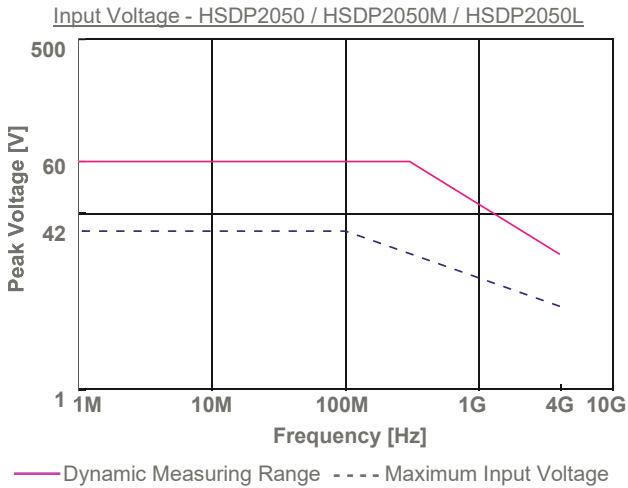
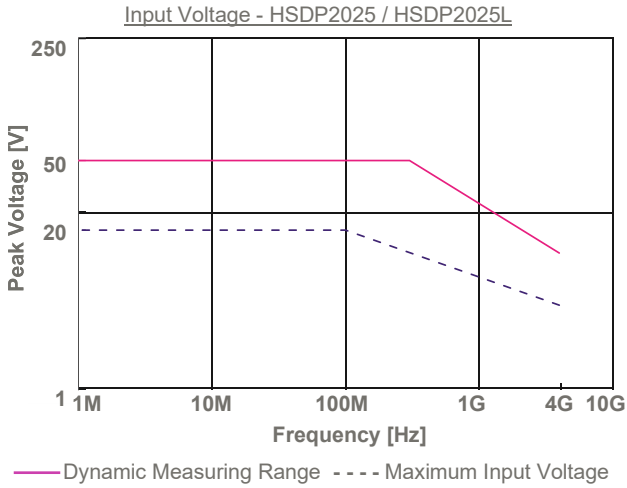

## Typical Rise Time

The typical rise time plots are coming soon.

## Ordering Information

A power supply with remote control capabilities or a battery pack for portable use are required and optional. The standard accessories are listed in Step 3.

### Step 1: Select Probe

Order No.	Item
<b>HSDP4010</b>	Differential probe 4GHz, $\pm 8V$ differential, $\pm 60V$ common mode, 10:1, low noise, 1.3m, including set of standard accessories
<b>HSDP2010</b>	Differential probe 2GHz, $\pm 8V$ differential, $\pm 60V$ common mode, 10:1, low noise, 1.3m, including set of standard accessories
<b>HSDP2010L</b>	Differential probe 1.8GHz, $\pm 8V$ differential, $\pm 60V$ common mode, 10:1, low noise, 7.5m, including set of standard accessories
<b>HSDP2025</b>	Differential probe 2GHz, $\pm 20V$ differential, $\pm 60V$ common mode, 25:1, low noise, 1.3m, including set of standard accessories
<b>HSDP2025L</b>	Differential probe 1.8GHz, $\pm 20V$ differential, $\pm 60V$ common mode, 25:1, low noise, 7.5m, including set of standard accessories
<b>HSDP2050</b>	Differential probe 2GHz, $\pm 42V$ differential, $\pm 60V$ common mode, 50:1, low noise, 1.3m, including set of standard accessories
<b>HSDP2050M</b>	Differential probe 1.8GHz, $\pm 42V$ differential, $\pm 60V$ common mode, 50:1, low noise, 3.5m, including set of standard accessories
<b>HSDP2050L</b>	Differential probe 1.8GHz, $\pm 42V$ differential, $\pm 60V$ common mode, 50:1, low noise, 7.5m, including set of standard accessories

### Step 2: Select Power Supply



The power supply pin assignment is different from other power supplies. Use only original PMK power supplies with PMK probes.

Order No.	Item
<b>889-09V-PS2</b>	PS-02 (2 channels, with USB interface for remote control)
<b>889-09V-PS2-L</b>	PS-02-L (2 channels, with LAN and USB interface for remote control)
<b>889-09V-PS3</b>	PS-03 (4 channels, with USB interface for remote control)
<b>889-09V-PS3-L</b>	PS-03-L (4 channels, with LAN and USB interface for remote control)
<b>889-09V-AP01</b>	AP-01 (battery pack, 1 channel, no remote control)
<b>890-520-900</b>	Power supply cable (0.5 m), included in probe's scope of delivery
<b>890-520-915</b>	Power supply cable (1.5 m)

Observe Connector Pin-Out  
for PMK power supply cables

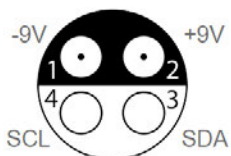

### Step 3: Accessories







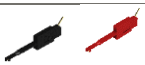

The accessories for this probe series have been safety tested.  
Do not use any other accessories or power supplies than what is recommended.

Order No.	Item	Scope of Delivery	Bandwidth (-3dB)	Picture
variable	Differential probe HSDP series model	x	variable	
890-808-105	2-Footer, black	x	n/a	
891-010-814	PCB adaptors, 10x	x	> 2.5 GHz	
890-800-001	Spring tips, gold-plated, 5x	x	> 2.5 GHz	
890-800-000	Solid tips, gold-plated, 5x	x	> 2.5 GHz	
899-000-002	SMD test grabber, 1 Pair, green/yellow	x	> 0.6 GHz	
890-600-214	Solder-In Adapter Flex PCB with Micro coax cable	x	> 1.2 GHz	
890-720-8A6	Y-Lead-Adaptor, 0.8mm Socket to MMCX plug	x	> 1.5 GHz	
018-292-937	Tip Saver	x	> 2.2 GHz	
018-291-913	Z-Ground, 1 pair	x	> 2 GHz	
018-291-914	Active Probe Bent Tip, 1 pair	x	> 1.5 GHz	
890-720-001	Y-Lead to 0.8mm socket for use with 899-000-002 and 890-500-001	x	n/a	
890-600-215	Adapter UF.L with Micro coax cable (optional)		> 1.3 GHz	
890-720-002	Y-Lead-R to 0.8 mm socket, compatible with Micro SMD-Clip 972416100	x	> 1.1 GHz	





Continues on next page.

### Step 3: Accessories (Continued)

Order No.	Item	Scope of Delivery	Bandwidth (-3dB)	Picture
890-500-001	QFP IC-Clips long, 1 Pair, black/red	x	> 0.6 GHz	
972416100	Micro SMD clip	x	> 0.5 GHz	
890-010-912	Marker bands 4 x 4 colors	x	n/a	
890-400-808	Ground lead 7cm	x	n/a	
890-400-809	Ground lead 13cm	x	n/a	
890-520-900	Power Supply Cable (0.5 m)	x	n/a	
n/a	Factory Calibration Certificate	x	na	

### Step 4: Select 3D Positioning System

Select one of PMK's 3D probe positioning systems with the universal probe holder. The arms and probe holders are also compatible to PMK's SKID positioning systems for probes and PCBs, which are also available for temperature ranges from -55°C to +155°C. To review all 3D positioning solutions, visit us at [www.pmk.de](http://www.pmk.de)

Order No.	Item	Picture
893-350-006	Universal 3D Probe Positioner MSU1500 with steel base (893-100-001), arm with span width 200mm (893-200-200), universal probe holder (893-090-000)	
893-350-011	Universal 3D Probe Positioner with magnet foot (893-100-004), arm with span width 200mm (893-200-200), universal probe holder (893-090-000)	
893-500-START	SKID-S Starter Kit: 3U Board Tester (160 x 160mm) including SKID vertical adapter kit (893-291-501), universal probe holder (893-090-000), PMK probe holder 5-12mm (893-050-000), arm with span width 130 mm (893-200-130) and with 200 mm (893-200-200)	
893-600-START	SKID-M Starter Kit: 6U Board Tester (240 x 160mm) including SKID vertical adapter kit (893-291-501), universal probe holder (893-090-000), PMK probe holder 5-12mm (893-050-000), arm with span width 130 mm (893-200-130) and with 200 mm (893-200-200)	
893-700-START	SKID-M Starter Kit: Board Tester (340 x 300mm) including SKID vertical adapter kit (893-291-501), universal probe holder (893-090-000), PMK probe holder 5-12mm (893-050-000), arm with span width 130 mm (893-200-130) and with 200 mm (893-200-200)	









Mess- und Prüftechnik. Die Experten.

**Ihr Ansprechpartner /  
Your Partner:**

**dataTec AG**

E-Mail: [info@datatec.eu](mailto:info@datatec.eu)

>>> [www.datatec.eu](http://www.datatec.eu)

**Copyright © 2024 PMK - All rights reserved.**

Information in this publication supersedes that in all previously published material.  
Specifications are subject to change without notice.

Informationen in dieser Anleitung ersetzen die in allen bisher veröffentlichten Dokumenten.  
Änderungen der Spezifikationen vorbehalten.