

PS0004A/6A/8A Optically-Isolated Differential Probes

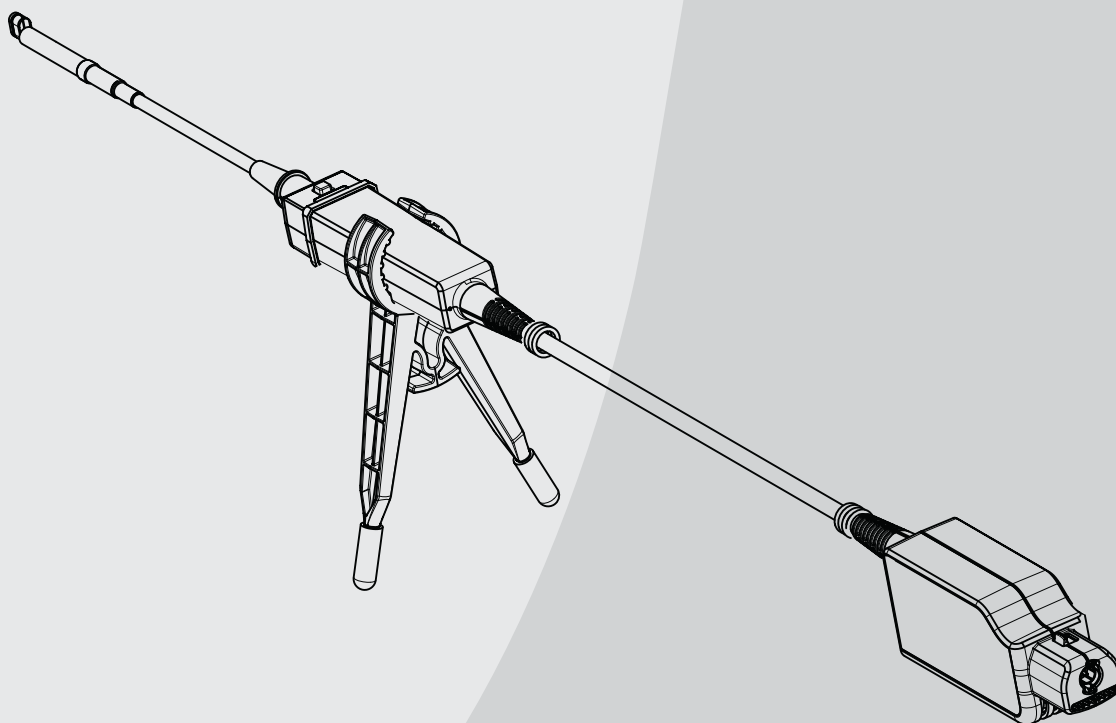

Mess- und Prüftechnik. Die Experten.

Ihr Ansprechpartner /
Your Partner:

dataTec AG
E-Mail: info@datatec.eu
>>> www.datatec.eu



KEYSIGHT

Authorized Premium
Distributor

Notices

© Keysight Technologies, 2025

No part of this manual may be reproduced in any form or by any means (including electronic storage and retrieval or translation into a foreign language) without prior agreement and written consent from Keysight Technologies, Inc. as governed by United States and international copyright laws.

Manual Part Number

PS0002-97000

Edition

First Edition, March 2025

Published by:
Keysight Technologies, Inc.

1900 Garden of the Gods Road
Colorado Springs, CO 80907 USA

Warranty

The material contained in this document is provided “as is,” and is subject to being changed, without notice, in future editions. Further, to the maximum extent permitted by applicable law, Keysight disclaims all warranties, either express or implied, with regard to this manual and any information contained herein, including but not limited to the implied warranties of merchantability and fitness for a particular purpose. Keysight shall not be liable for errors or for incidental or consequential damages in connection with the furnishing, use, or performance of this document or of any information contained herein. Should Keysight and the user have a separate written agreement with warranty terms covering the material in this document that conflict with these terms, the warranty terms in the separate agreement shall control.

Technology Licenses

The hardware and/or software described in this document are furnished under a license and may be used or copied only in accordance with the terms of such license.

U.S. Government Rights

The Software is "commercial computer software," as defined by Federal Acquisition Regulation ("FAR") 2.101. Pursuant to FAR 12.212 and 27.405-3 and Department of Defense FAR Supplement ("DFARS") 227.7202, the U.S. government acquires commercial computer software under the same terms by which the software is customarily provided to the public. Accordingly, Keysight provides the Software to U.S. government customers under its standard commercial license, which is embodied in its End User License Agreement (EULA), a copy of which can be found at

<http://www.keysight.com/find/sweula>. The license set forth in the EULA represents the exclusive authority by which the U.S. government may use, modify, distribute, or disclose the Software. The EULA and the license set forth therein, does not require or permit, among other things, that Keysight: (1) Furnish technical information related to commercial computer software or commercial computer software documentation that is not customarily provided to the public; or (2) Relinquish to, or otherwise provide, the government rights in excess of these rights customarily provided to the public to use, modify, reproduce, release, perform, display, or disclose commercial computer software or commercial computer software documentation. No additional government requirements beyond those set forth in the EULA shall apply, except to the extent that those terms, rights, or licenses are explicitly required from all providers of commercial computer software pursuant to the FAR and the DFARS and are set forth specifically in writing elsewhere in the EULA. Keysight shall be under no obligation to update, revise or otherwise modify the Software. With respect to any technical data as defined by FAR 2.101, pursuant to FAR 12.211 and 27.404.2 and DFARS 227.7102, the U.S. government acquires no greater than Limited Rights as defined in FAR 27.401 or DFAR 227.7103-5 (c), as applicable in any

technical data. 52.227-14 (June 1987) or DFAR 252.227-7015 (b)(2) (November 1995), as applicable in any technical data.

Safety Notices

CAUTION

A **CAUTION** notice denotes a hazard. It calls attention to an operating procedure, practice, or the like that, if not correctly performed or adhered to, could result in damage to the product or loss of important data. Do not proceed beyond a **CAUTION** notice until the indicated conditions are fully understood and met.

WARNING

A **WARNING** notice denotes a hazard. It calls attention to an operating procedure, practice, or the like that, if not correctly performed or adhered to, could result in personal injury or death. Do not proceed beyond a **WARNING** notice until the indicated conditions are fully understood and met.

Contents

1 Overview

Introduction	6
Key Features	6
Probe Components	7
Standard Accessories	9
Additional Accessories	10
Probe Tips	10
Other Optional Accessories	11
How Do Isolated Probes Work?	13
Compatibility with Keysight Oscilloscopes	14

2 Characteristics and Specifications

Electrical Specifications and Characteristics	16
Environmental Characteristics	18
Probe Tips Input Impedance	19
MMCX Probe Tips (PS0017A/18A/19A)	20
100 mil Pitch Socket Probe Tips (PS0022A/23A/25A)	22
200 mil Pitch Socket Probe Tips (PS0027A/28A)	24
Typical CMRR	26
Typical Step Responses and Rise-times	27
Non-Destructive Derating and Maximum Usable Signal Range Plots for Probe Tips	28
MMCX Probe Tips (PS0017A/18A/19A)	29
100 mil Pitch Socket Probe Tips (PS0022A/23A/25A)	30
200 mil Pitch Socket Probe Tips (PS0027A/28A)	32
Mechanical Characteristics	34
Probe Dimensions	34
Probe Tip Dimensions	34
Bipod Dimensions	35

3 Setting up and Using PS0004A/6A/8A Probes

Connecting the Probe to an Oscilloscope	38
Using Channel Identification Rings	38
Connecting the Probe Tip to the Probe	39
Connecting the Probe Tip to the Probe Sensor Head	39
Supporting the Probe using the Supplied Bipod	39
Assembling the PS0014A Isolated Probe Adapter for the 3D Probe Positioner	39

Connecting the Probe to the DUT	44
Calibrating the PS0004A/6A/8A Probes	45
Performing Deskew Procedure	46
Calibrating Default Skew	46
Calibrating with MMCX Probe Tip (PS0017A) and PV Fixture Kit (PS0015A)	46
Deskewing Other Tips	46
Performance Verification	47
Before you Start	47
Bandwidth Verification	47
Performance Test Record	57

4 Safety and Regulatory Information

Safety Checks and Warnings	60
Safety Requirements when Connecting to a Circuit	61
Safety and Regulatory Symbols	63
Safety Circuit	64
Mesures de sécurité et avertissements	65
Procédures de sécurité lors de la connexion à un circuit	66
Symboles de sécurité et de réglementation	68
Cleaning the Probe and its Parts/Accessories	70
Cleaning the AutoProbe I Interface and Probe Pogo Pins	70

5 Returning the Probe

Contacting Keysight Technologies for Technical Assistance	75
---	----

Index

1 Overview

Introduction	6
Standard Accessories	9
Optional Accessories	10
How Do Isolated Probes Work?	13
Compatibility with Keysight Oscilloscopes	14

Introduction

The PS0004A/6A/8A are high voltage optically-isolated differential probes that allow you to safely make high speed and high voltage measurements such as measurements for power supplies, converters, and electric vehicles.

Key Features

- **Optical isolation between sensor head and probe pod** - Optical isolation is achieved by transmitting power, signals, and control messages optically using fiber optic cables between the sensor head and probe pod. The fiber optic cables isolate the sensor head potential from the probe pod and oscilloscope case (that are at earth ground) thereby making these probes suitable for floating measurements with minimal Device Under Test (DUT) loading. Though this isolation allows measurements with high frequency / high voltage common mode components, it is crucial to follow safety requirements to ensure safe isolation from hazardous input voltages. See **“Safety Checks and Warnings”** on page 60 to know about the safety requirements when the probe is connected to an energized test circuit.
- **Multiple probe tip options with different connector types and measurement ranges** - The probe tips support connections to MMCX connectors (board mount/SMT) as well as 100 and 200 mil square pin headers. These tips support different bandwidth, input impedance, and input voltage ranges. You can select a tip based on the required input voltage range to reduce the signal to noise ratio.
- **Signals acquisition up to 1 GHz** - Probe variants are available to support 350 MHz to 1 GHz bandwidth.
- **High differential voltage probing capabilities in the presence of high common-mode voltages with good common-mode rejection performance** -
 - Supports high voltage (up to ± 2500 V) based on the probe tip being used.
 - Gate to source measurements with high voltage and high frequency common mode signals
 - High common mode rejection -80 dB at high frequency

See also **“How Do Isolated Probes Work?”** on page 13.

Probe Components

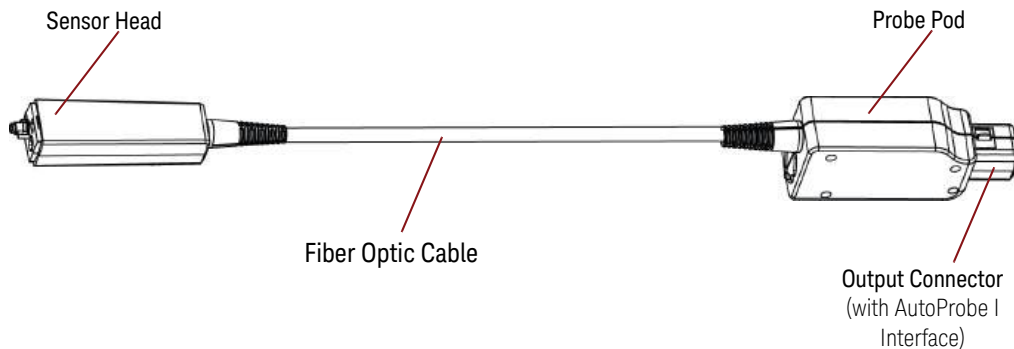



Figure 1 PS0004A/6A/8A Probe Components

PS0004A/6A/8A Probe Component	Description
Sensor Head	<p>The sensor head connects to DUT via a Keysight compatible probe tip. It receives DUT signals from the probe tip, converts these electrical signals to optical signals, and transmits these optical signals to the probe pod.</p> <p>CAUTION Do not connect the sensor head directly to DUT. Always use the sensor head with one of the probe tips (see “Probe Tips” on page 10) to make the connection to DUT.</p>
Fiber Optic Cable	<p>The fiber optic cable provides optical connections for:</p> <ul style="list-style-type: none"> ▪ transmitting measurement signals from sensor head to probe pod. ▪ transmitting power from probe pod to sensor head. ▪ communicating control messages and configuring safety-related mechanisms between the probe pod and sensor head.

PS0004A/6A/8A Probe Component	Description
Probe Pod/Output Connector	<p>The probe pod connects to an input channel of the oscilloscope via the AutoProbe I connector. It performs Optical-to-Electrical (O/E) conversion on the optical signals received from the sensor head and transmits the resulting electrical signals to the oscilloscope.</p> <p>CAUTION Handle the AutoProbe I pod with care when placing it on hard surfaces. The pogo pins for the AutoProbe I interface are delicate and can be easily damaged.</p> <p>The output connector has the Keysight AutoProbe I interface that allows these probes to connect to a compatible Keysight oscilloscope (see "Compatibility with Keysight Oscilloscopes" on page 14). This AutoProbe I connector is used to:</p> <ul style="list-style-type: none">▪ transmit DUT signals to the oscilloscope.▪ receive probe power from the oscilloscope.▪ support communication between oscilloscope and probe such as auto-configuration of the probe type and attenuation setting on connection.

Standard Accessories

The accessories listed below ship standard with these probes. You can use these accessories interchangeably across PS0004A/6A/8A probes.

Standard Accessory	Part Number	Description
SMA Wrench (Qty 1)	8710-2466	To connect the probe tip to the sensor head by tightening the SMA connector
		
Bipod Probe Positioner (Qty 1)	PS0013-64701	<p>To hold the probe in place while making measurements and to support a hands-free usage model.</p> <p>The Bipod is recommended for:</p> <ul style="list-style-type: none"> ▪ High frequency measurements (reduced capacitance to DUT) ▪ High frequency common mode voltages (reduced loading on the DUT) ▪ Reduce stress on DUT connection
		

Additional Accessories

Besides the standard accessories that are shipped with these probes, replacement and additional accessories are also available that you can order separately.

Probe Tips

The following figure displays the three types of probe tips that are available as additional accessories for PS0004A/6A/8A probes. Each of these probe tip types are available with different input voltage ratings. These variants are listed below with their part numbers and associated maximum differential input voltages.

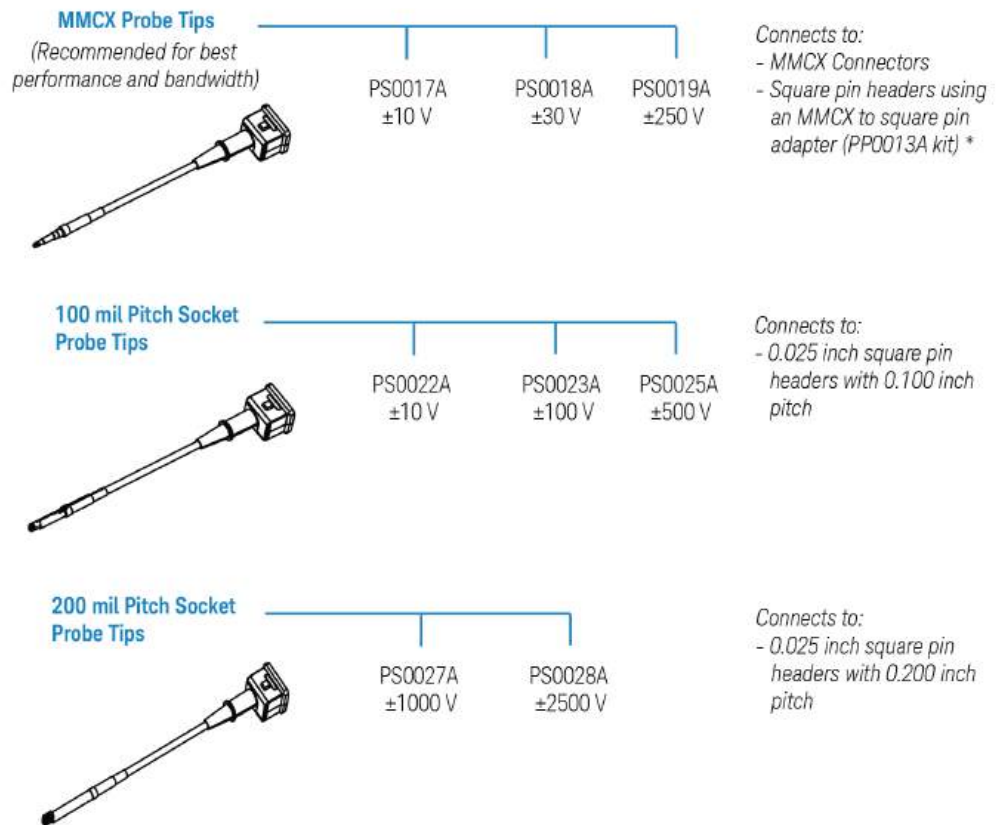

* The MMCX to square pin adapter in the PP0013A kit offers limited performance when used with PS0004A/6A/8A probes.

Figure 2 Additional Accessories for PS0004A/6A/8A Probes

See also “[Electrical Specifications and Characteristics](#)” on page 16.

Other Optional Accessories

Table 1 lists the other optional accessories that you can order separately.

Table 1 List of Other Optional Accessories

Part Number	Description
PS0015A	Deskew and Performance Verification Fixture Kit
PS0014A	Isolated Probe Adapter
PS0010A	Basic Connectivity Kit
PS0011A	Solder-in Connectivity Kit

Deskew and Performance Verification Fixture Kit (PS0015A)

PS0015A Kit	Accessory Included in the Kit	Quantity
	Deskew Fixture	1
	SMA (male) to SMA (male) Adapter	1
	SMA (male) to BNC (female) Adapter	1
	BNC (male) to SMA (male) Adapter	1
	50 Ω SMA Terminator	1

You can use the PS0015A kit to verify the performance of PS0004A/6A/8A probes when used with the PS0017A probe tips.

CAUTION

The PS0015A PV fixture is meant only for deskew and performance verification of your probe. It is not designed for any other testing purpose. This fixture is safely rated to the maximum of $30 V_{\text{rms}}/42 V_{\text{pk}}/60 V_{\text{dc}}$. Do not use it on voltages higher than this rating.

Isolated Probe Adapter (PS0014A)

The Adapter is a specialized component designed for the 3D Probe Positioner. This adapter helps in ensuring precise positioning and stability of probes. Since the adapter comes disassembled, you must assemble it before connecting to the 3D Probe Positioner. See [“Assembling the PS0014A Isolated Probe Adapter for the 3D Probe Positioner”](#) on page 39 for the assembly instructions of the adapter.

The adapter assembly resembles [Figure 3](#) with the probe attached.



Figure 3 Example of the Adapter with Probe

How Do Isolated Probes Work?

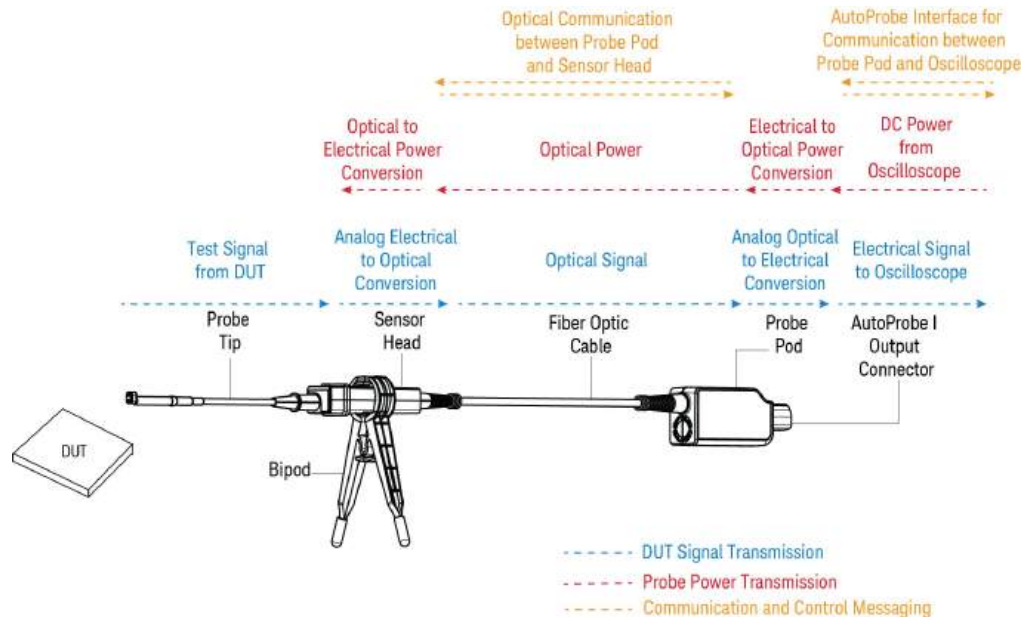

Figure 4 Working of the PS0004A/6A/8A Probes

As illustrated in the above picture, all signal, power, and communication between the probe pod and sensor head are optical which make these probes galvanically isolated and suitable for high voltage and high frequency common-mode signals.

The following is a brief description of how these probes work to provide safe isolation to the probe pod and oscilloscope when measuring high frequency/high voltage signals.

- **DUT Signal Transmission** - When the probe tip transmits a signal from the DUT, it is attenuated and converted to an optical signal in the sensor head. This optical signal is transmitted to the probe pod. In the probe pod, the signal is converted from the optical signal to a low voltage electrical signal which is transmitted to the oscilloscope via the AutoProbe I interface.
- **Probe Power Transmission** - The probe gets its power from the oscilloscope via the AutoProbe I interface. This low voltage DC power is converted and transmitted as optical power from probe pod to the sensor head. The sensor head performs the required conversion to use this optical power as electrical power.
- **Communication and Control Messaging**
 - Communication and messaging between the probe pod and sensor head is done on separate fiber optic cables.
 - Communication and low voltage DC power transmission between the oscilloscope and probe pod is done via the AutoProbe I interface.

Compatibility with Keysight Oscilloscopes

Compatible Oscilloscopes	Adapter(s) Required	Required Software Version
Infiniium Oscilloscopes		
EXR-Series	None	Infiniium 11.70 or higher
MXR-Series	None	Infiniium 11.70 or higher

Is your oscilloscope software up-to-date?

Keysight periodically releases software updates to support your probe, fix known defects, and incorporate product enhancements. To download the latest firmware, go to www.Keysight.com and search for your oscilloscope's model number. Click the “**Drivers, Firmware & Software**” tab under the **Technical Support** link.

2 Characteristics and Specifications

Electrical Specifications and Characteristics	16
Environmental Characteristics	18
Probe Tips Input Impedance	19
Typical CMRR	26
Typical Step Responses and Rise-times	27
Non-Destructive Derating and Maximum Usable Signal Range Plots for Probe Tips	28
Mechanical Characteristics	34

Electrical Specifications and Characteristics

NOTE

All entries included in this chapter are characteristics unless explicitly mentioned as warranted specifications.

Table 2 Warranted Specifications

Probe	Probe Tip	Bandwidth (-3 dB)
PS0004A		350 MHz
PS0006A	PS0017A MMCX Probe Tip	700 MHz
PS0008A		1 GHz

Table 3 Probes - Electrical Characteristics

NOTE

These characteristics are the typical performance values of the PS0004A/6A/8A probes when used with the PS0017A MMCX probe tip.

Characteristic	PS0004A	PS0006A	PS0008A
Probe Rise Time (10%-90%)		≤ 2 ns at 200 MHz ≤ 850 ps at 500 MHz ≤ 450 ps at 1 GHz	
Max. Differential Measurement Range (DC + AC peak) 		Tip dependent	
Max. Common Mode Voltage Range		± 60 kV	
DC Gain Accuracy		After calibration: 1% Pod or sensor within ± 2 °C of calibration: 1.5%	
Offset Error		After calibration: 0.5% Pod or sensor within ± 2 °C of calibration: 2%	
Overvoltage and Measurement Category per IEC -61010-031		Non-CAT (mains isolated) ^a	
Input Coupling of the oscilloscope		50 Ω AutoProbe I Interface	

^a IEC Measurement Category MAINS ISOLATED is for measurements performed on circuits not directly connected to mains.

Table 4 Probe Tips - Electrical Characteristics

NOTE

The electrical ratings given below are for probe tips only. As these probes are designed to be used with probe tips only, the lower of the electrical rating of the probe and of the tip is applicable for a probe + tip combination.

Connector Type	Probe Tip Model Number	Bandwidth	Maximum Differential Input Voltage (DC + AC peak)	Maximum Rated Input Voltage	Input Impedance
MMCX	PS0017A	1 GHz	±250 V	±10 V	10 MΩ 3 pF
	PS0018A			±30 V	
	PS0019A			±250 V	
100 mil pitch socket	PS0022A	1 GHz	±500 V	±10 V	10 MΩ 3.5 pF
	PS0023A			±100 V	
	PS0025A			±500 V	
200 mil pitch socket	PS0027A	1 GHz	±2500 V	±1000 V	40 MΩ 3.5 pF
	PS0028A			±2500 V	

Table 5 Input Referred Noise

Probe Model/Tip	PS0017A	PS0018A	PS0019A	PS0022A	PS0023A	PS0025A	PS0027A	PS0028A
PS0004A	20 mV _{rms}	60 mV _{rms}	504 mV _{rms}	20 mV _{rms}	201 mV _{rms}	1.00 V _{rms}	2.074 V _{rms}	5.20 V _{rms}
PS0006A	25 mV _{rms}	76 mV _{rms}	637 mV _{rms}	25 mV _{rms}	254 mV _{rms}	1.27 V _{rms}	2.62 V _{rms}	6.58 V _{rms}
PS0008A	32 mV _{rms}	96 mV _{rms}	802 mV _{rms}	32 mV _{rms}	320 mV _{rms}	1.60 V _{rms}	3.30 V _{rms}	8.29 V _{rms}

Environmental Characteristics

Characteristic	Probe Pod	Sensor Head	Probe Tip
Temperature			
Operating	5 °C to +40 °C	0 °C to +55 °C	-40 °C to +85 °C
Non-operating	-40 °C to +70 °C	-40 °C to +70 °C	-40 °C to +85 °C
Altitude			
Operating	3,100 m (10,171 ft)	3,100 m (10,171 ft)	3,100 m (10,171 ft)
Non-operating	4,600 m (15,092 ft)	4,600 m (15,092 ft)	4,600 m (15,092 ft)
Humidity			
Operating	Up to 80% RH at 40 °C, non-condensing	Up to 85% RH at 55 °C, non-condensing	Up to 85% RH at 85 °C, non-condensing ^a
Non-operating	+40 °C, 95% RH (\leq 39.0 °C Dew Point) derated linearly to 25% RH at 70 °C		
Pollution Degree	2 ^b (rated for indoor use only)		

^a Qualified for 140 hours of continuous use.

^b Normally only non-conductive pollution occurs. Occasionally, however, a temporary conductivity caused by condensation must be expected.

Probe Tips Input Impedance

This section provides:

- Input impedance plots for the different probe tips to show the matching of the measured data to the modeled data. Matching is generally very good up to the specified bandwidth of the probe tips.
- Equivalent circuit schematics for the different probe tips.
- SPICE models for the different probe tips. This SPICE model is only for input impedance which allows modeling of the probe loading effects.

NOTE

The input impedances shown in this section are between the probe tip and shield of the various tips. The shield impedance to the surrounding environment is reduced to around 2 pF at higher frequencies by the ferrite beads on the shield under the jacket of the tip. If possible, when connecting to a DUT, the shield side should be connected to a DUT node with the lower impedance to limit the loading effect on the DUT.

MMCX Probe Tips (PS0017A/18A/19A)

Input Impedance Plot

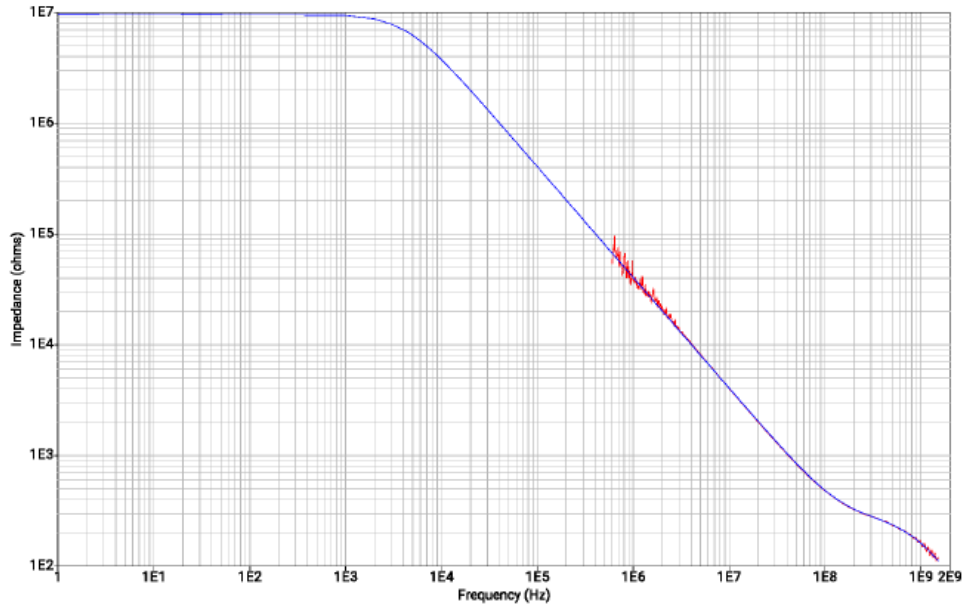

Equivalent Circuit Schematics

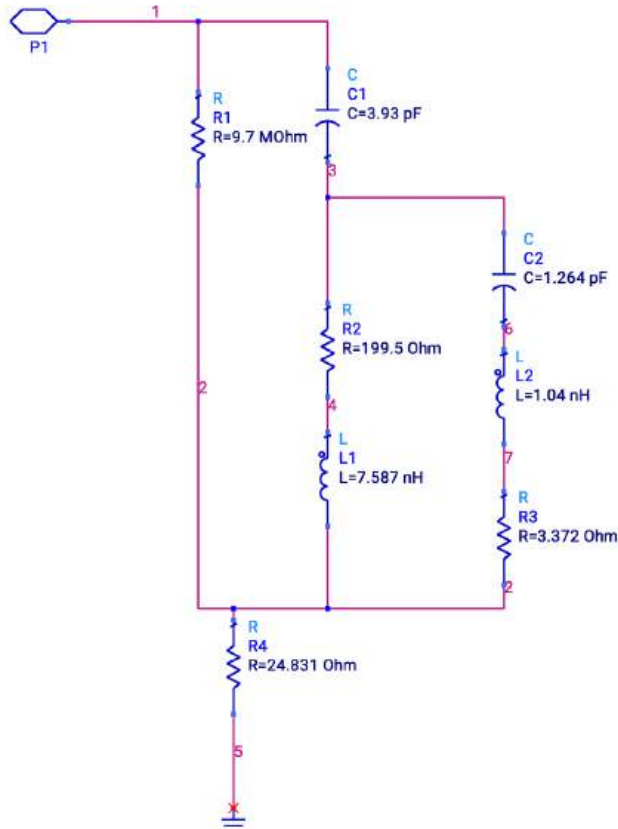

SPICE Model

```
#PS0017A
.subckt PS0017A 1 5
R1 1 2 9.7MEG
C1 1 3 3.93p
R2 3 4 199.5
L1 4 2 7.587n
C2 3 6 1.264p
L2 6 7 1.04n
R3 7 2 3.372
R4 2 5 24.831
.END
```

100 mil Pitch Socket Probe Tips (PS0022A/23A/25A)

Input Impedance Plot

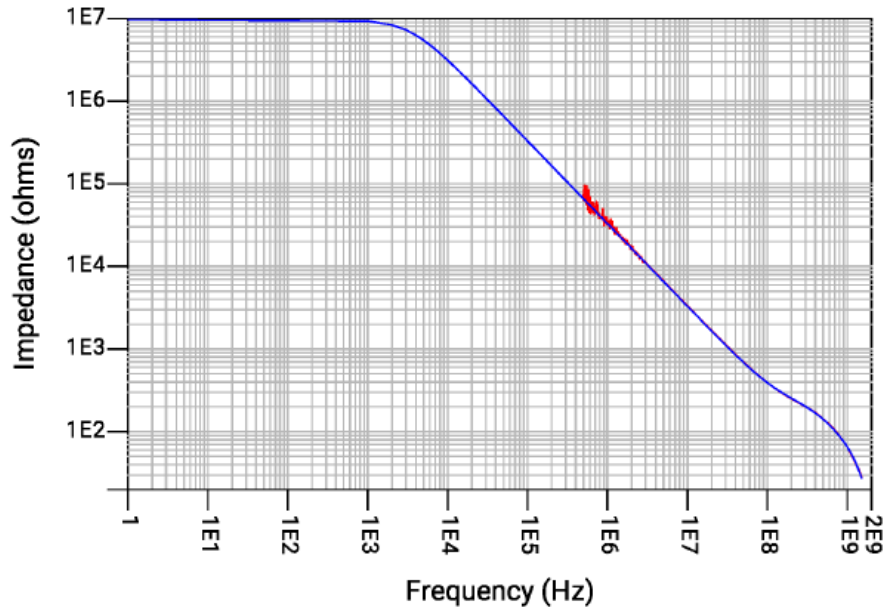

Equivalent Circuit Schematics

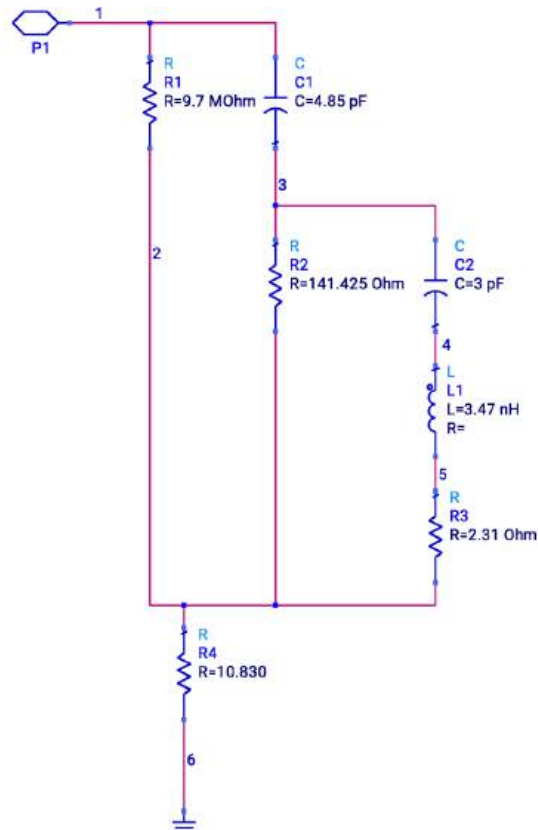

SPICE Model

```
#PS0022A
.subckt PS0022A 1 6
R1 1 2 9.7MEG
C1 1 3 4.85p
R2 3 2 141.425
C2 3 4 3p
L1 4 5 3.47n
R3 5 2 2.31
R4 2 6 10.830
.END
```

200 mil Pitch Socket Probe Tips (PS0027A/28A)

Input Impedance Plot

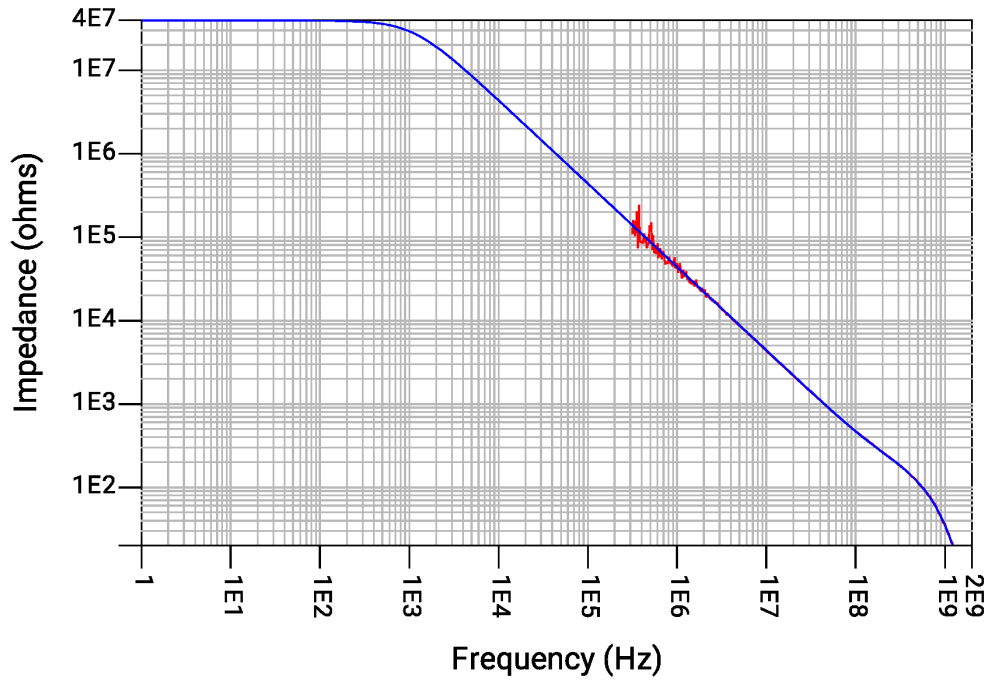

Equivalent Circuit Schematics

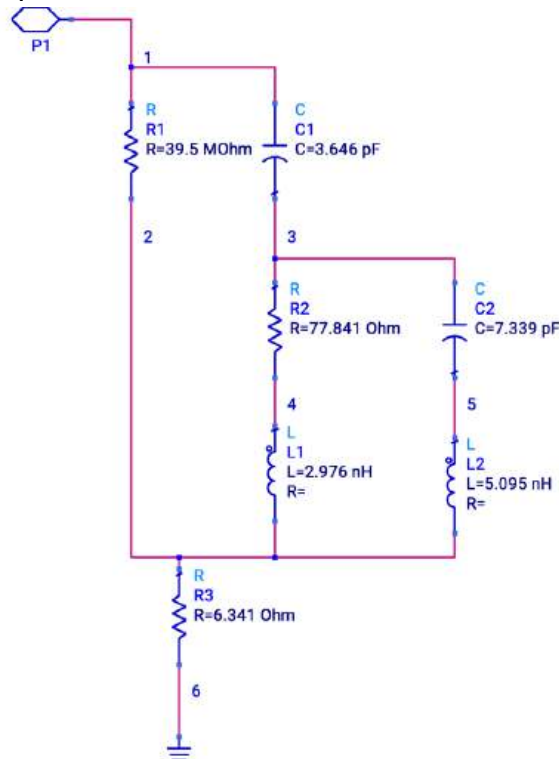

SPICE Model

```
#PS0027A
.subckt PS0027A 1 6
R1 1 2 39.5MEG
C1 1 3 3.646p
R2 3 4 77.841
L1 4 2 2.976n
C2 3 5 7.339p
L2 5 2 5.095n
R3 2 6 6.341
.END
```

Typical CMRR

If an optically isolated probe is held with a non-conducting probe holder that has virtually no DC leakage to the surrounding environment (i.e., very high resistance), then the DC CMRR becomes unmeasurable in practice and can be considered nearly infinite. The CMRR shown in the plot is measured from 100 kHz to 1 GHz and is not extrapolated. Measurement below 100 kHz becomes beyond most measurement techniques.

Figure 5 shows the typical CMRR for the PS0008A probe and all the probe tips combination.

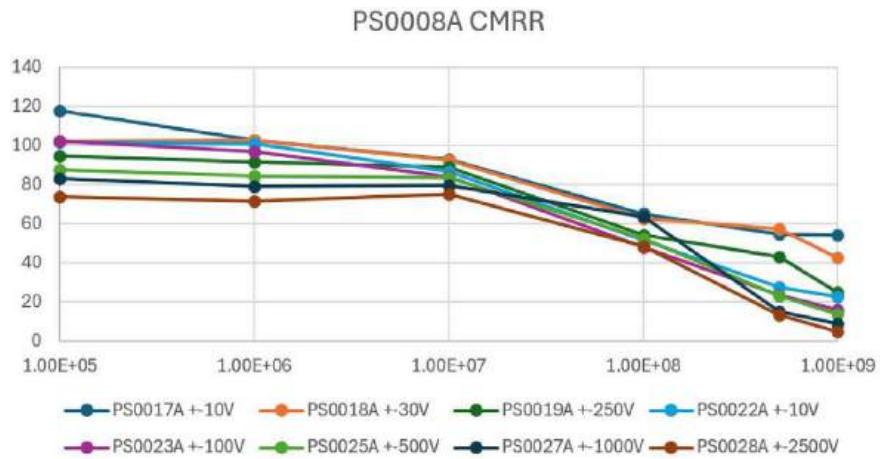

Figure 5 CMRR of the PS0008A Probe with all the Probe Tips

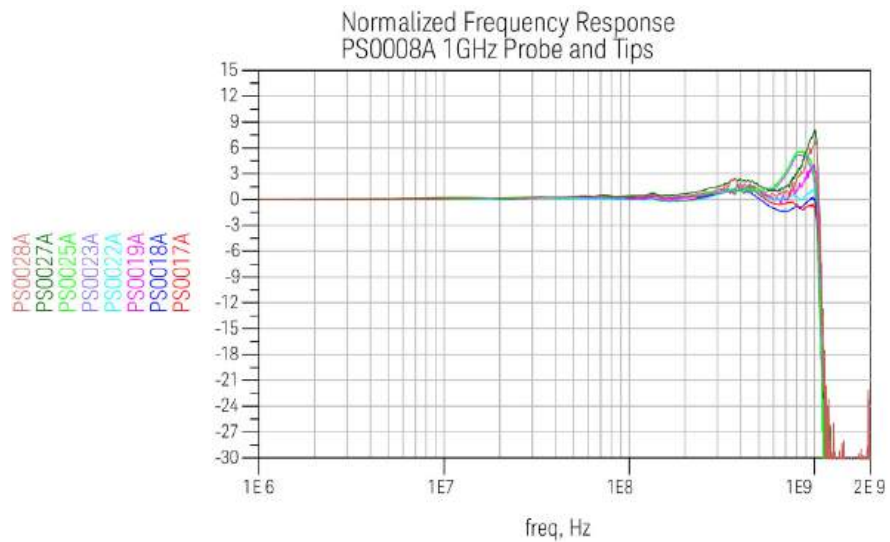

Figure 6 Normalized frequency response of the PS0008A Probe and Tips

Typical Step Responses and Rise-times

Figure 7 shows the typical step responses and rise-times for the PS0008A probe and all the probe tips combination.

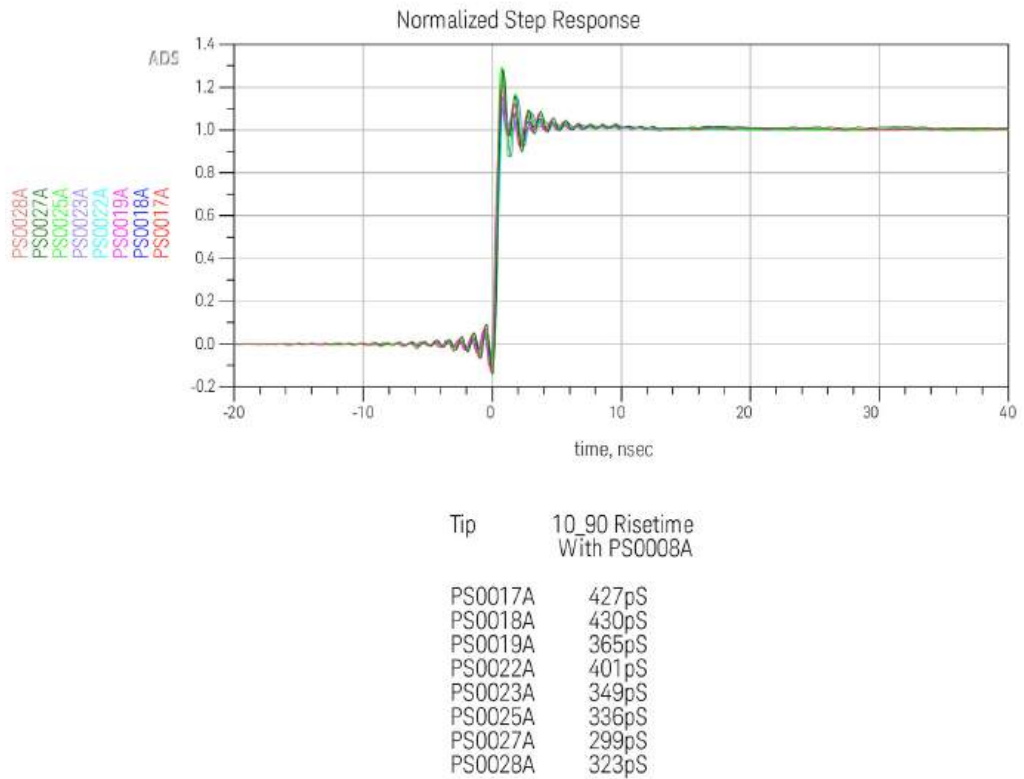

Figure 7 Step Responses and Rise-Times of the PS0008A Probe with all the Probe Tips

Non-Destructive Derating and Maximum Usable Signal Range Plots for Probe Tips

Figure 8 shows the representation of probe tip input voltage (that is, AC, DC, and common mode limits).

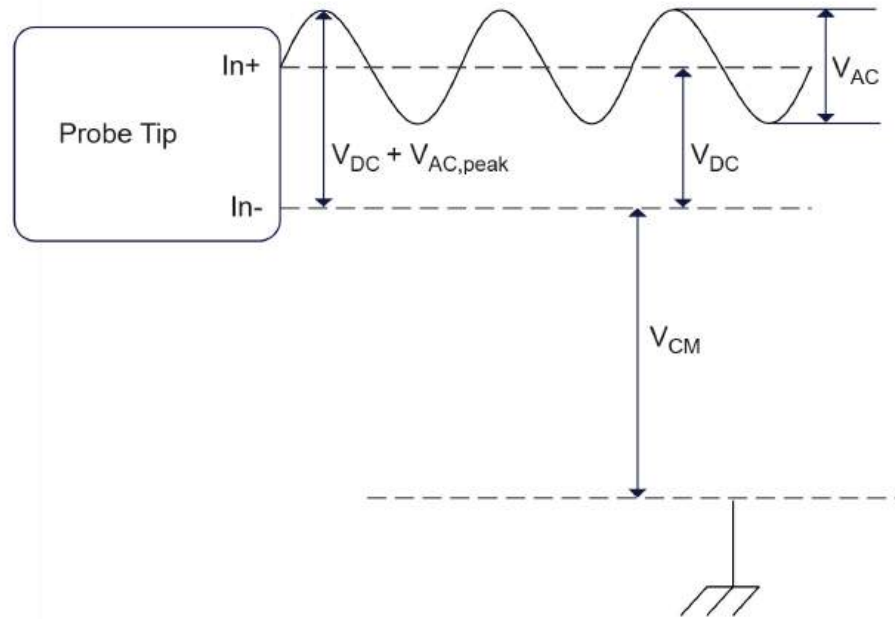

Figure 8 Input Voltage Terms

MMCX Probe Tips (PS0017A/18A/19A)

Probe Tip	Max Measurable Differential Signal $V_{AC,peak}+V_{DC}-V_{OFFSET}$, derated with frequency	Max Measurable AC differential Signal $V_{AC,peak}$, derated with frequency	Max Non-Destructive Differential voltage $V_{AC,peak}+V_{DC}$, derated with frequency	Max Offset (V)
PS0017A	±10 V	±10 V	±250 V	±250 V
PS0018A	±30 V	±30 V	±250 V	±250 V
PS0019A	±250 V	±250 V	±250 V	±250 V

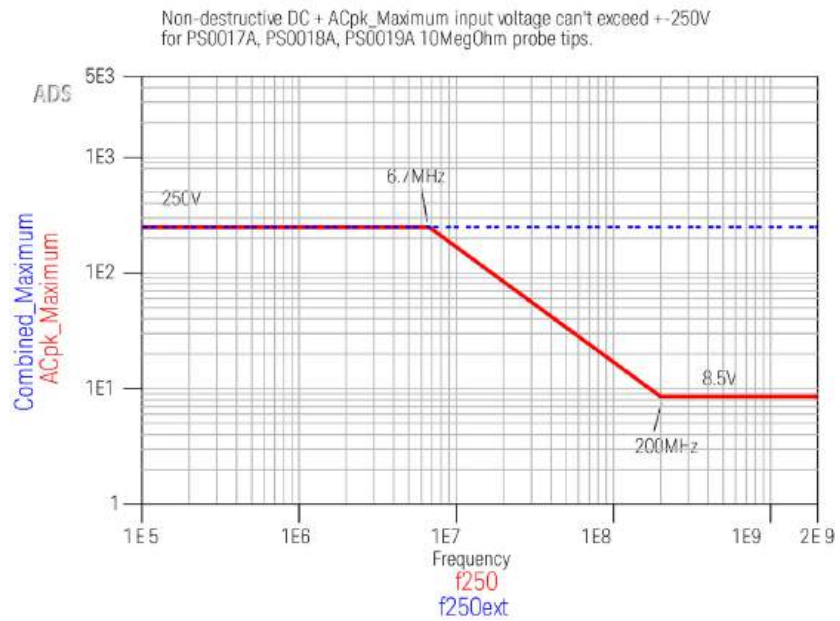

Figure 9 Non-destructive derating plot for MMCX probe tips

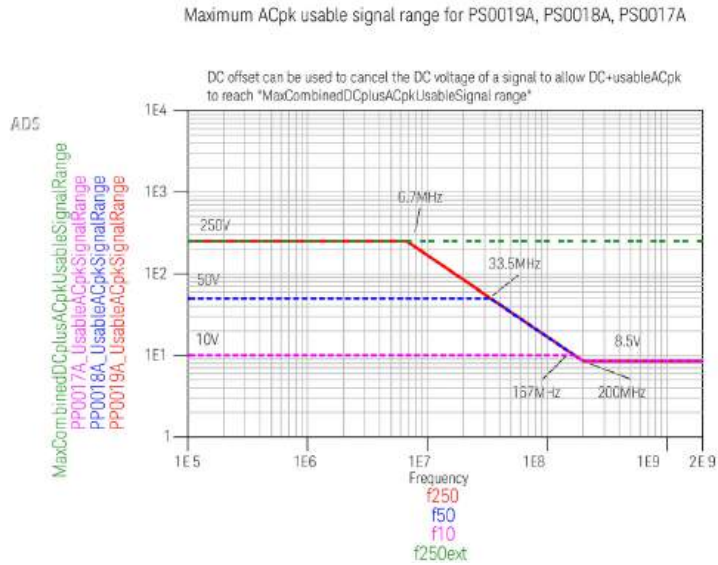

Figure 10 Maximum usable signal range plot for MMCX probe tips

100 mil Pitch Socket Probe Tips (PS0022A/23A/25A)

Probe Tip	Max Measurable Differential Signal $V_{AC,peak} + V_{DC} - V_{OFFSET}$, derated with frequency	Max Measurable AC differential Signal $V_{AC,peak}$, derated with frequency	Max Non Destructive Differential voltage $V_{AC,peak} + V_{DC}$, derated with frequency	Max Offset (V)
PS0022A	±10 V	±10 V	±500 V	±250 V
PS0023A	±100 V	±100 V	±500 V	±500 V
PS0025A	±500 V	±500 V	±500 V	±500 V

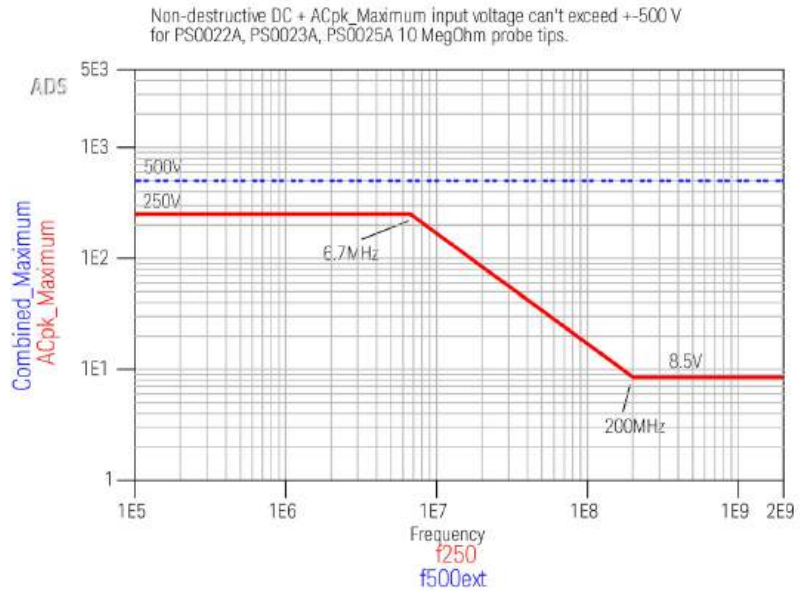

Figure 11 Non-destructive derating plot for 100 mil pitch socket probe tips

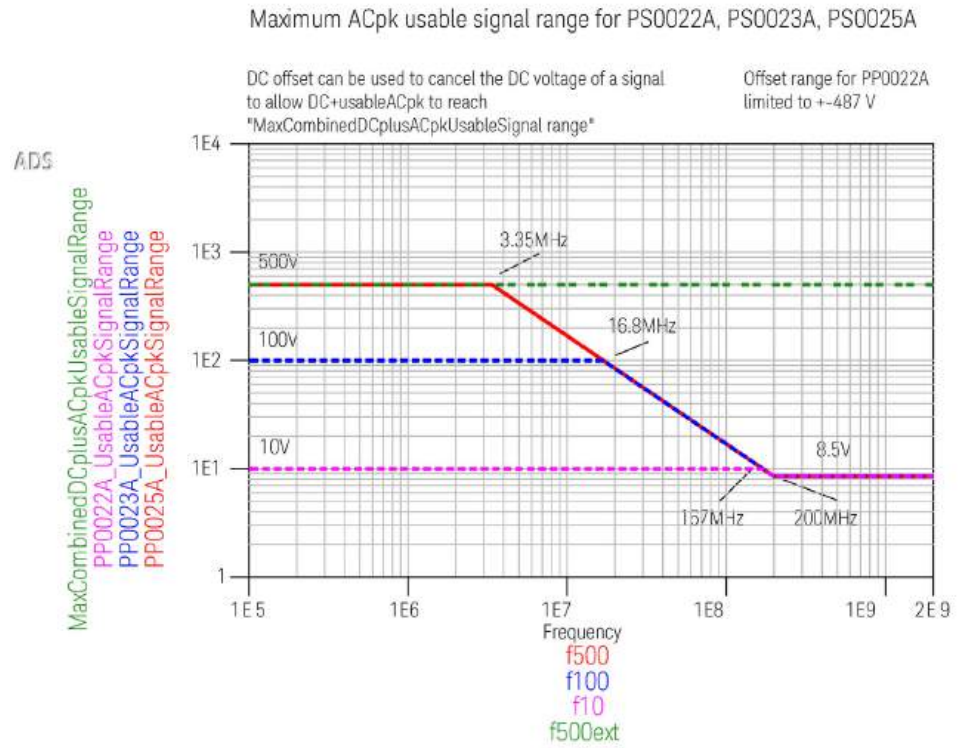

Figure 12 Maximum usable signal range plot for 100 mil pitch socket probe tips

200 mil Pitch Socket Probe Tips (PS0027A/28A)

Probe Tip	Max Measurable Differential Signal $V_{AC,peak}+V_{DC}-V_{OFFSET}$, derated with frequency	Max Measurable AC differential Signal $V_{AC,peak}$, derated with frequency	Max Non Destructive Differential voltage $V_{AC,peak}+V_{DC}$, derated with frequency	Max Offset (V)
PS0027A	±1000 V	±1000 V	±2500 V	±2500 V
PS0028A	±2500 V	±2500 V	±2500 V	±2500 V

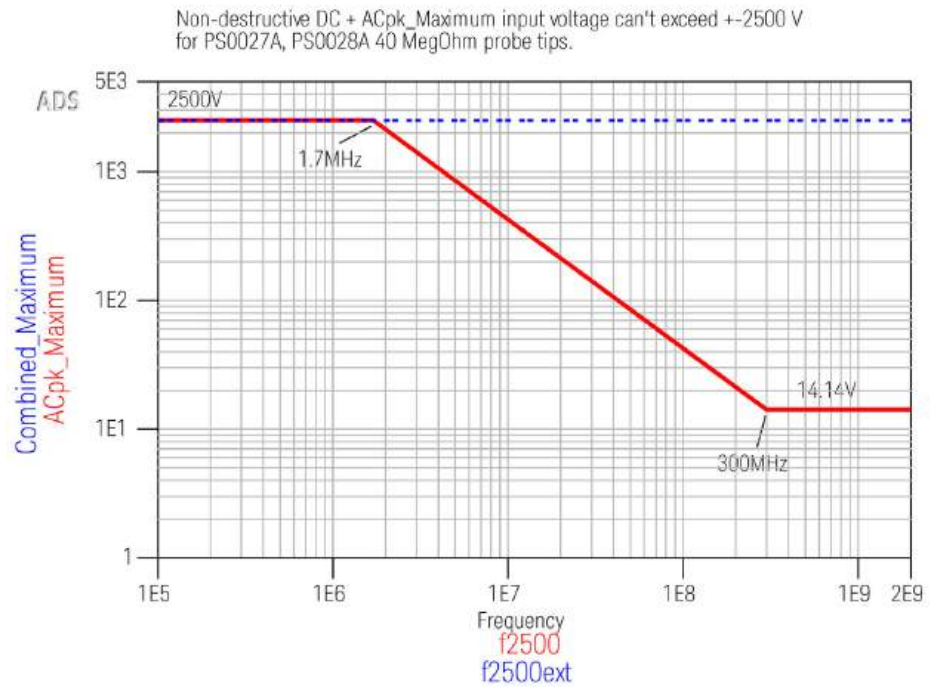

Figure 13 Non-destructive derating plot for 200 mil pitch socket probe tips

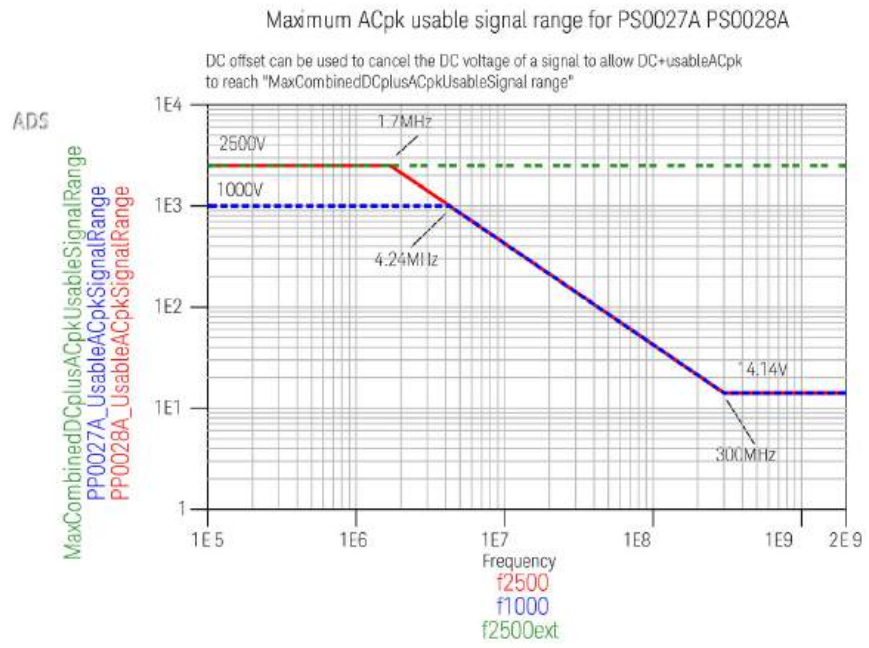

Figure 14 Maximum usable signal range plot for 200 mil pitch socket probe tips

Mechanical Characteristics

Characteristic	Value
PP0004A/6A/8A Probe Cable Length	2 m
Probe Cable Type	Optical fiber bundle
Probe mass (without a tip or other accessories)	375 g
Probe tip average mass	40 g

Probe Dimensions

All dimensions are in millimeters.

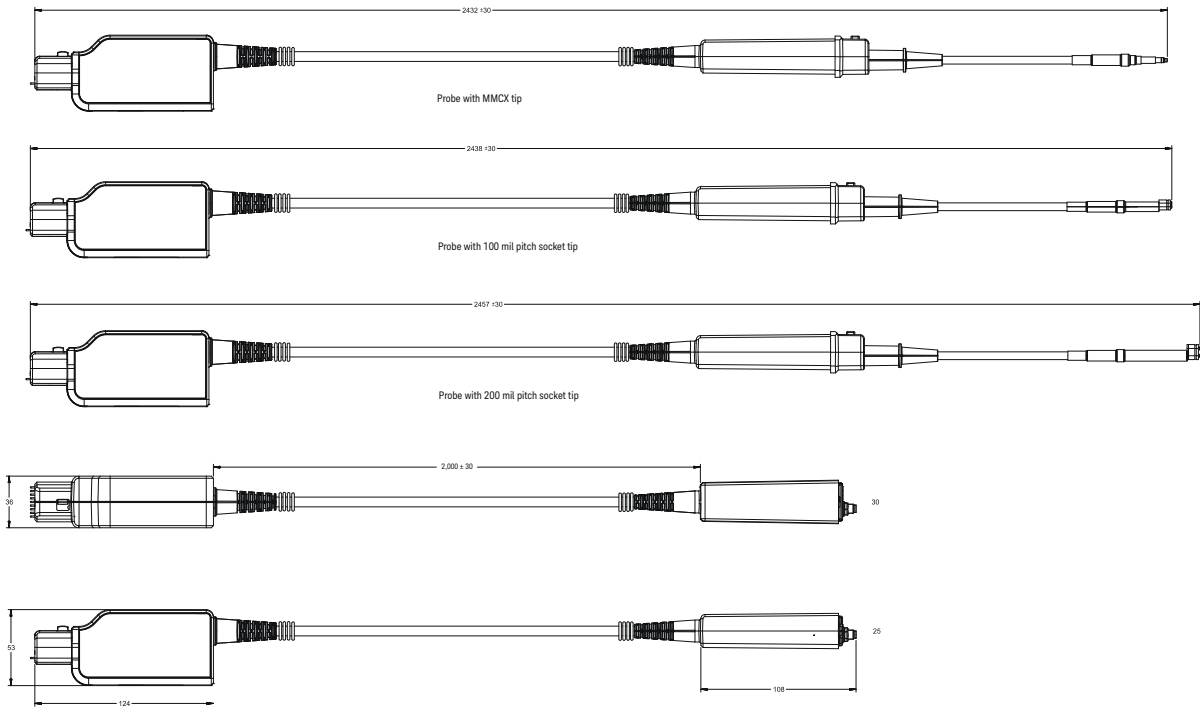

Figure 15 PP0004A/6A/8A Probe Dimensions

Probe Tip Dimensions

All dimensions are in millimeters.

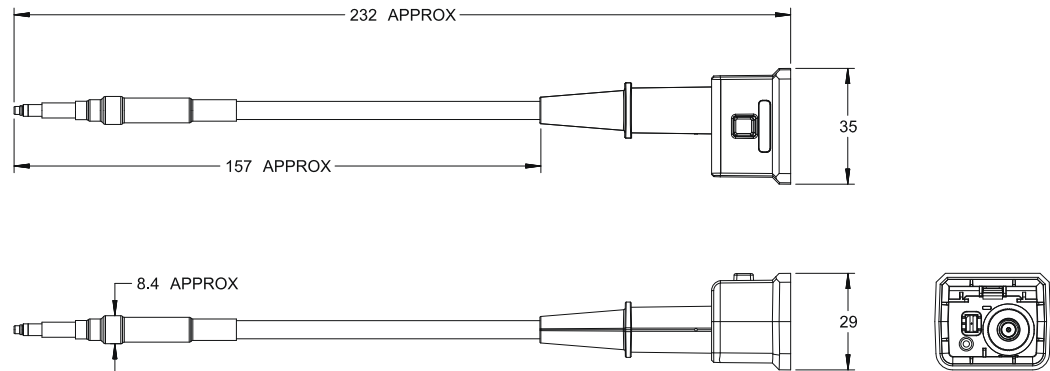

Figure 16 MMCX Probe Tip Dimensions

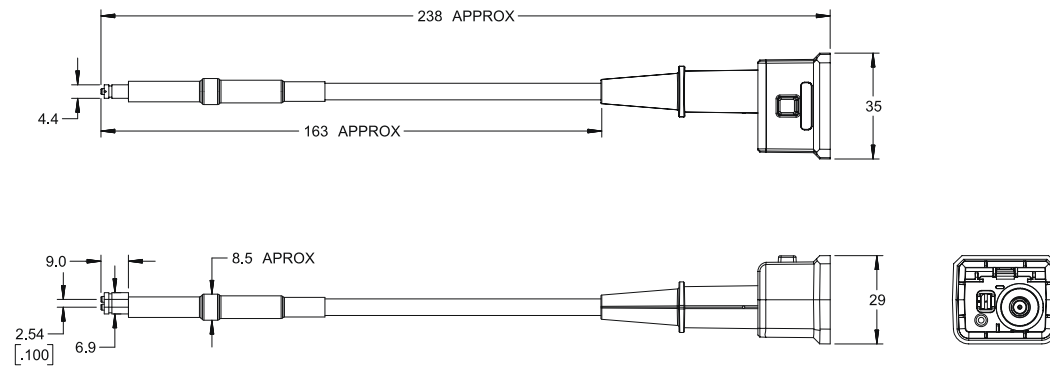

Figure 17 100 Mil Pitch Socket Probe Tip Dimensions

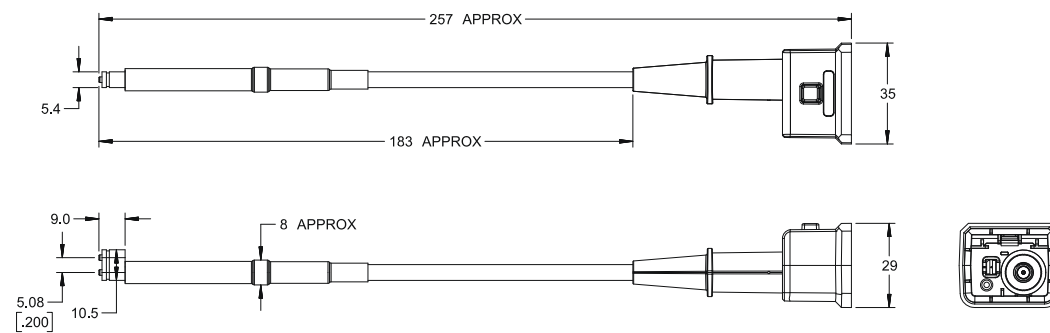

Figure 18 200 Mil Pitch Socket Probe Tip Dimensions

Bipod Dimensions

All dimensions are in millimeters.

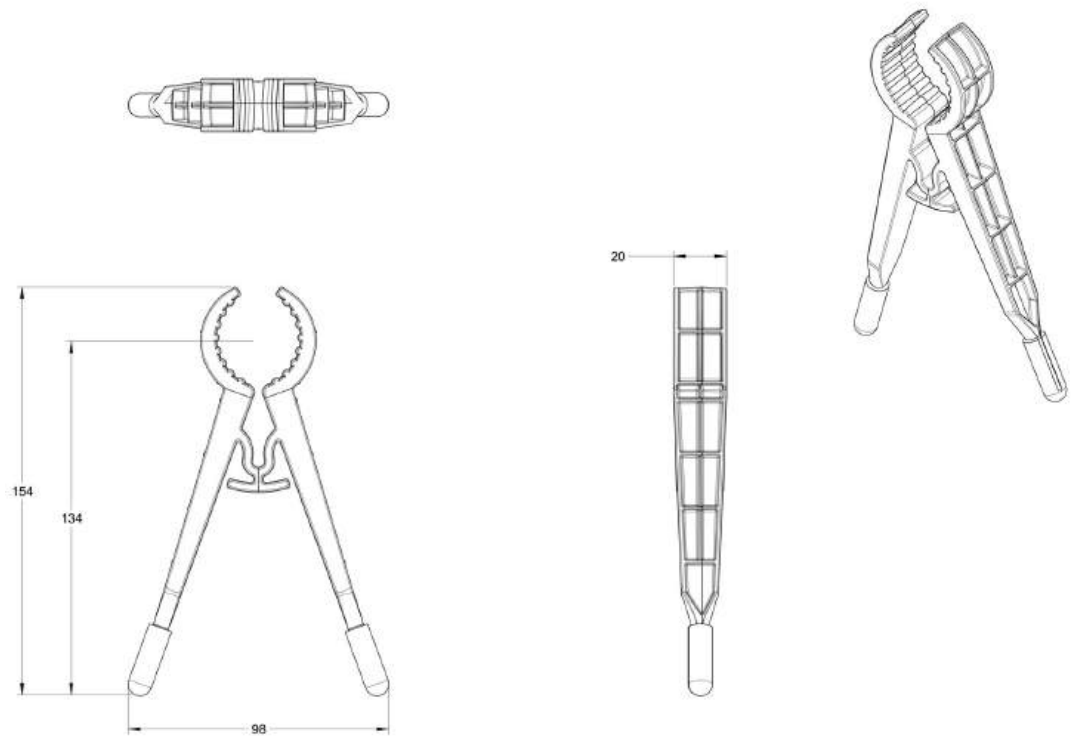

Figure 19 Bipod Dimensions

3 Setting up and Using PS0004A/6A/8A Probes

Connecting the Probe to an Oscilloscope 38

Connecting the Probe Tip to the Probe 39

Calibrating the PS0004A/6A/8A Probes 45

Performing Deskew Procedure 46

Performance Verification 47

CAUTION

Optically isolated probes may be used in the presence of high frequency/high voltage common mode signals, carefully read and follow the warnings and cautions given in the safety chapter.

Connecting the Probe to an Oscilloscope

NOTE

These probes are designed for ground-referenced measurements. Connect the probe to the oscilloscope input before connecting to the DUT.

- 1 Connect the probe to an input channel of a compatible Keysight oscilloscope by gently pushing the probe onto the connector on the oscilloscope's input channel. As the probe is pushed, the lever on top of the probe moves to the left. When the probe is fully seated, the lever returns to the locked position.

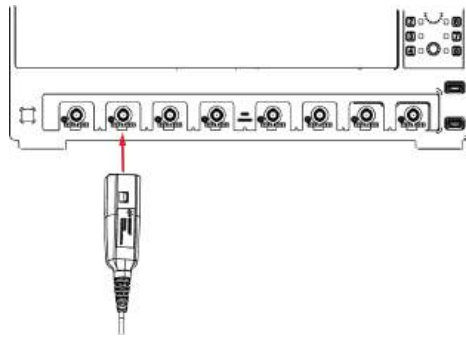

Using Channel Identification Rings

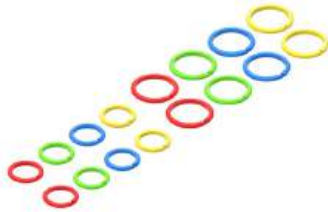

When multiple probes are connected to the oscilloscope, you can quickly identify which probe is connected to each oscilloscope channel by using the supplied channel identification rings.

Place rings of the same color on each end of the probe's cable.

Using these rings ensures that you can pick up a probe and immediately know which channel it is connected to without having to track the cable back to the oscilloscope's channel input.

Connecting the Probe Tip to the Probe

Connecting the Probe Tip to the Probe Sensor Head

NOTE

Always use a probe tip to make measurements.

- 1 Choose an appropriate probe tip that meets your measurement requirement (see **“Optional Accessories”** on page 10).
- 2 The probe tip connects to the sensor head of the probe. To make this connection:
 - a Align and connect the SMA connector by finger-tightening or using the wrench supplied with the probe. Do not over-tighten.
 - b Gently push the probe tip housing into the sensor head to fully engage and seat it in place.

Supporting the Probe using the Supplied Bipod

- 1 Squeeze the PS0013A Bipod Probe Positioner legs to widen its grip so that it can hold the probe.
- 2 Slide the probe body into the bipod’s grip and rest its sensor head part on the bipod. The bipod reduces stress on the DUT connection as well as provides a firm support to the sensor head of the probe.
- 3 Place the setup of the probe, probe tip and bipod assembly on the required test location.

Assembling the PS0014A Isolated Probe Adapter for the 3D Probe Positioner

Table 6 lists and **Figure 20** shows all the parts of the adapter required to complete the assembly. Follow the procedure below to assemble it. Once assembled, the adapter must be connected to the 3D Probe Positioner.

Table 6 List of Adapter Parts

Serial Number	Part Number	Quantity	Description
1	0380-5984	1	Standoff-HEX Female-Female M6X1 51mm-LG Nylon-66
2	0515-7111	1	Screw-Machine Flat-HD Phillips M6X1.0 12mm-LG SST-316 Passivated DIN 965
3	PS0014-27701	1	Body - Probe Adapter to 3D Positioner
4	1400-3934	2	Cable-Tie 1/2X8-in-Size Black



Figure 20 Different parts of the adapter

- 1 Attach the Hex Standoff to the Adapter Body:
 - a Align the hex standoff with the hexagonal recess on the bottom face (see [Figure 21](#)) of the adapter body.



Figure 21 Bottom face of the adapter body



Figure 22 Top face of the adapter body

- b** Insert the machine screw through the top face of the body (see [Figure 22](#)) and tighten it into the standoff until secure (see [Figure 23](#)).



Figure 23 Image of the hex standoff attachment

2 Fasten the Adapter Body with Cable Ties:

- a** Insert and pull out the open end of a Velcro cable tie through the holes near the hexagonal stand in the manner shown in **Figure 24**.



Figure 24 Attaching the cable tie to the body

- b** Loop the cable tie around the body and fasten it securely. This will ensure it grips the probe correctly.

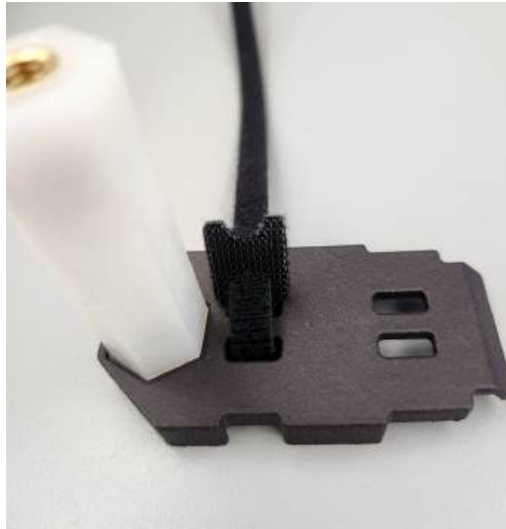

Figure 25 Fastening the cable tie

- c Repeat the above steps for the second cable tie so that the assembly looks like **Figure 26**.



Figure 26 Image showing both the cable ties fastened

- 3 Final Assembly Check:
 - a Ensure all parts are securely attached.
 - b Place the probe on the adapter body and secure it by strapping the Velcro cable ties tightly.
 - c The assembly should resemble **Figure 27** with the probe attached.



Figure 27 Example of the Adapter with Probe

Connecting the Probe to the DUT

- 1 Ensure that the probe tip is installed.
- 2 Ensure that the probe is attached to the oscilloscope.
- 3 Ensure that the DUT is powered down.
- 4 Connect the probe to the DUT.

NOTE

The probe is not intended for handheld use or browsing a powered up DUT.

Calibrating the PS0004A/6A/8A Probes

Allow your Keysight isolated probe to warm up for 30 minutes after powering it on. This warm-up period helps stabilize gain and DC drift, which are dependent on self-heating and environmental temperature changes.

When you first connect the probe to the oscilloscope, it automatically calibrates. This initial calibration ensures basic accuracy.

After the initial calibration, a calibration prompt appears in the following cases:

- After the initial 30-minute warm-up.
- Whenever the internal temperature of the probe's pod or sensor changes by 2 °C.

While calibrations are optional, performing them ensures you meet nominal and specified accuracy. You can initiate calibration in either of the following two ways:

- Use the probe menu, and then click the prompts on the oscilloscope software GUI.
- Via a SCPI command.

You don't need to disconnect your DUT during calibration. The probe's internal relay automatically disconnects the DUT, and an internal source provides the necessary calibration signal.

Between calibrations, the probe automatically compensates for drift to maintain measurement accuracy.

Performing Deskew Procedure

Calibrating Default Skew

Each probe contains a default skew value stored in the IDROM, which is programmed during the manufacturing process. This value is an initial estimate, and you can perform further calibration to achieve more precise adjustments.

Calibrating with MMCX Probe Tip (PS0017A) and PV Fixture Kit (PS0015A)

- 1 Use the PS0017A probe tip (10 V) and the PS0015A kit to calibrate the probe.
- 2 Follow the standard probe deskew procedure in the oscilloscope software to accurately adjust the skew.
- 3 Retain the PS0017A skew as it accurately accounts for the rest of the probe with minimal variation between tips.

Deskewing Other Tips

For tips other than the PS0017A, apply the skew value derived from the PS0017A calibration. This value should suffice due to minimal variation across tips.

However, if you need precise calibration, use a double-probing method by doing the following:

- 1 Probe an appropriate signal with both the probe tips.
- 2 Adjust the channel skew to align their timings accurately.

Performance Verification

This section describes how to verify the warranted electrical characteristics (Bandwidth) of the PS000xA probes.

Before you Start

WARNING

The procedures documented in this chapter require the application of high voltage to the inputs of the PS000xA probe. Ensure that you follow all pertinent safety rules and guidelines for elevated voltage measurements. Only qualified personnel should perform any testing with voltage levels exceeding 30 V_{rms} .

WARNING

Generators produce hazardous voltages. To avoid risk of shock, do not touch exposed metal parts after the generator output is enabled.

NOTE

Allow the probe to warm up for at least 20 minutes before the initiating the performance verification procedure.

Recommended Test Interval

The recommended test interval is 1 year.

Bandwidth Verification

The procedure described in this section can be used to Bandwidth Verification Procedure for 1 GHz PS0008A Isolated Probe.

Equipment Required

Table 7 Required Test Equipment for Bandwidth Verification

Description	Critical Specification(s)	Recommended Model / Part Number & Adapters	Purpose
DUT to measure		PS0017A MMCX tip and PS0008A probe	
Oscilloscope	Infiniium EXR or MXR oscilloscope	Bandwidth ≥ 2 GHz	To display probe output
Deskew and Performance Verification Fixture		PS0015A MMCX Performance verification fixture kit	
Probe holder			
BNC cable			

Setup

The following image shows the setup for the Performance Verification procedure.



Procedure

- 1 Connect the PS0017A MMCX probe tip and PS0008A probe to an Oscilloscope Channel, hereafter referred to as the “Probe Channel” in this procedure.
- 2 Insert both the SMA to BNC adapters from the PS0015A kit on the PS0015A fixture.
- 3 Connect the fixture to another Channel, hereafter referred to as the “Fixture Channel” in this procedure.
- 4 Connect Oscilloscope’s AUX output to the fixture.
- 5 Connect the PS0017A probe tip to the PS0008A probe. Then, tighten the SMA connector and snap the plastic cap on the probe body.
- 6 Use a probe holder to position the tip and connect the tip to the MMCX connector on PV fixture.
- 7 On the Infiniium software of your Oscilloscope:
 - a Click **Default Setup**.
 - b Enable the “Probe Channel” and “Fixture Channel” only. In the images below, Ch1 is selected as Probe Channel and Ch2 is selected as Fixture Channel.
 - c From the main menu,
 - Click **Utilities > Calibration Output....** Set the **Signal Output** to **Probe Comp**.



- Click **Setup > Acquisition....** Set **Analog Averaging** to **Enabled** and set the **# of Averages** to **1024**.



- d For the Fixture Channel,
 - Set **Impedance** to **50 ohms**.
 - Set **Scale** to **200 mV/div**.
 - Set **Offset** to **-250 mV**.



- e For the Probe Channel,
 - Set **Scale** to **200 mV/div**.
 - Set **Offset** to **-250 mV**.



- f From the main menu, click **Trigger**.
 - Set **Source** as the Fixture Channel.

- Set **Level** to **-250mV**.
- Set **Edge** to the positive rising slope.

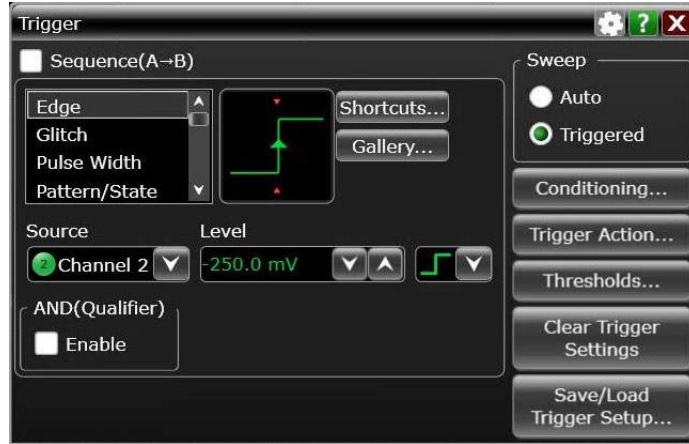

- g Allow 15 minutes for the probe to warm up. Then, click **Setup > Probe Calibration** to initiate probe calibration.
- h On the Probe Channel, adjust the **Skew** to center the Probe Channel's step horizontally.
- i Set timebase to **10 ns/div**.
- j From the main menu, click **Math > Function**.
 - Configure **f1** settings: Do not select the **On** check box. In the **Function 1** area, select **Math > Differentiate**. Select **Source** as the Probe Channel. Do not select the **Low Pass and Align Phase** check box.

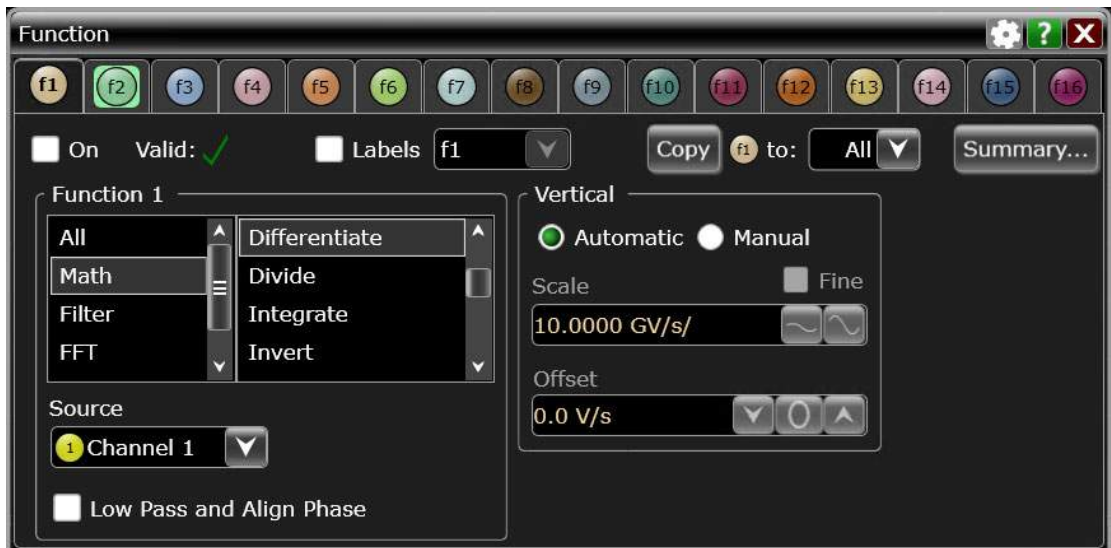

- Configure **f2** settings: Select the **On** check box. In the **Function 2** area, select **FFT > FFT Magnitude**. Select **Source** as **f1:Diff(Ch1)**. Set the **Stop** frequency to **2 GHz**. Set **Vertical Scale** to **3 dBm/**. Adjust the **Vertical Reference Level** to center f2 vertically at approx. **168 dbm**.



- Configure **f3** settings: Do not select the **On** check box. In the **Function 3** area, select **Math > Differentiate**. Select **Source** as the Fixture Channel. Do not select the **Low Pass and Align Phase** check box.

3 Setting up and Using PS0004A/6A/8A Probes



- Configure **f4** settings: Select the **On** check box. In the **Function 4** area, select **FFT > FFT Magnitude**. Select **Source** as **f3:Diff(Ch2)**. Set the **Stop** frequency to **2 GHz**. Set Vertical Scale to **3 dBm/**. Adjust the Vertical Reference Level to center f4 vertically at approx. **168 dbm**.



- Configure **f5** settings: Select the **On** check box. In the **Function 5** area, select **Math > Subtract**. Select **Source1** as **f4:FFTM(f3)** and **Source2** as **f2:FFTM(f1)**. Set **Vertical Scale** to **3 dBm/**. Adjust the **Vertical Reference Level** to center f5 vertically at approx. **11.4 dbm**.

3 Setting up and Using PS0004A/6A/8A Probes

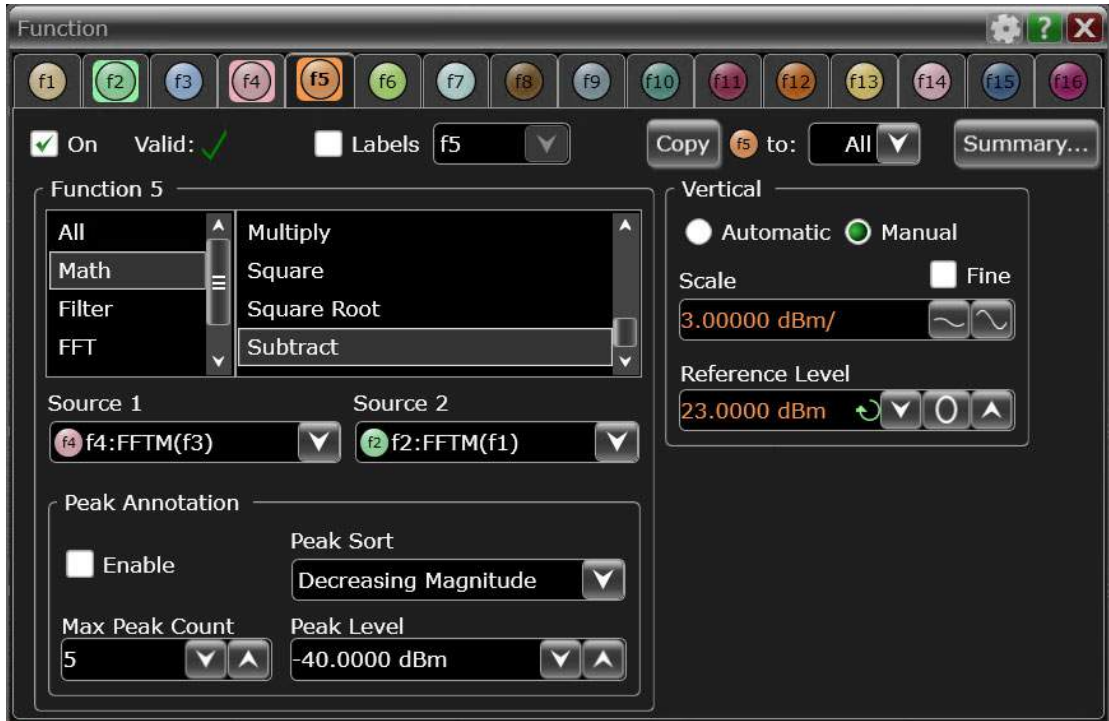

- k Shrink window with steps so FFT windows bigger.
- l Ensure that f5 is not more than 1 div below 3 db of its value at 50 MHz.

The following image shows the appearance of the signals on the Oscilloscope display with probe on channel1 and fixture on channel 2.



Performance Test Record

Table 8 Performance Test Record

Model #:	Date:	Tested by:	
Serial #:	Recommended next test date:		
Test	Test Limits	Result	Pass/Fail
Bandwidth (-3 dB)			

3 Setting up and Using PS0004A/6A/8A Probes

4 Safety and Regulatory Information

Safety Checks and Warnings	60
Safety and Regulatory Symbols	63
Mesures de sécurité et avertissements	65
Symboles de sécurité et de réglementation	68
Cleaning the Probe and its Parts/Accessories	70

Safety Checks and Warnings

These products have been designed and tested in accordance with accepted industry standards, and have been supplied in a safe condition. The documentation contains information and warnings that must be followed by the user to ensure safe operation and to maintain these products in a safe condition.

WARNING

If the probe assembly is used in a manner not specified by the manufacturer, the protection provided by it may be impaired.

WARNING

Use of controls or adjustments or performance of procedures other than those specified in the probe's documentation may result in hazardous radiation exposure.

WARNING

Do not attempt to remove any coverings from the sensor head and cable or disassemble the product. These probes are equipped with laser sources. Exposing these sources can put you at the risk of laser radiation exposure.

WARNING

Periodically inspect the probe wires and cables. Do not operate with visible/suspected damage. If you suspect a damage, have it inspected by a Keysight authorized service personnel.

WARNING

**Do not install substitute parts or perform any unauthorized modification to the probe / accessory.
Do not attempt internal service or adjustment. These probes are not serviceable. If the probe is defective, it should be made inoperative and returned to the Keysight sales office. See "Contacting Keysight Technologies for Technical Assistance" on page 75 to know more.**

WARNING

**Must be Grounded
Before connecting the probe's output connector to a channel input of the oscilloscope, ensure that the oscilloscope is properly grounded.**

WARNING

**Indoor Use Only.
Do not operate in wet/damp environments. Keep product surfaces dry and clean.**

WARNING

Do not operate the probe or oscilloscope in the presence of flammable gasses or fumes. Operation of any electrical instrument in such an environment constitutes a definite safety hazard.

CAUTION

Do not twist, tightly bend, pull, or kink the probe's fiber optic cable to avoid stressing the optical fibers.

When bending the probe's fiber optic cable, avoid tight bends and sharp angles that could damage the cable. The minimum bend radius of the cable is 2.5 inches (63.5 mm) and the smallest loop diameter is 5 inches (127 mm).

CAUTION

When not in use, keep the probe and its accessories in the product case.

CAUTION

Do not block the ventilation holes on the fan located on the probe pod.

Safety Requirements when Connecting to a Circuit

WARNING

Preventing Potential RF Burns/Electric Shock

Minimum clearance requirement for making measurements
As these probes support high frequency / high voltage common mode measurements, it is crucial to observe clearance requirements to ensure isolation from hazardous input voltages. You must remain at least 1 meter away from all sides of the probe's sensor head and probe tip cable whenever the probe is connected to an energized test circuit.

WARNING

Ensure that the test circuit is de-energized before you connect the probe tip to the test circuit and before you disconnect the probe tip from the test circuit.

WARNING



Observe Probe and Tips Voltage Ratings

Do not apply any electrical potential to the probe input that exceeds the maximum rating of the probe and tip. See **“Electrical Specifications and Characteristics”** on page 16 for maximum input voltage ratings.

These probe assemblies are **NOT** intended for measurements on circuits directly connected to mains (that is, CAT II, CAT III, or CAT IV circuits).



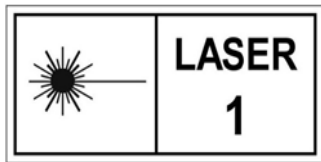



Laser Certification





CLASS 1 LASER PRODUCT

Class 1 laser system under “Normal Use” conditions
Complies with IEC 60825-1:2014 standards for laser systems.

Safety and Regulatory Symbols

Symbol	Description
	The product is marked with this symbol when it is necessary for the user to refer to the instructions in the documentation.
	Warning High Voltage - Possibility of electric shock
	These probes are Electrostatic Discharge (ESD) sensitive devices, particularly at the probe amplifier. Follow standard ESD precautions when handling these.
	This symbol indicates the Environmental Protection Use Period (EPUP) for the product's toxic substances for the China RoHS requirements.
	The crossed out wheeled bin symbol indicates that separate collection for waste electric and electronic equipment (WEEE) is required, as obligated by the EU DIRECTIVE and other National legislation. Please refer to keysight.com/go/takeback to understand your Trade in options with Keysight in addition to product takeback instructions.
	The CE mark is a registered trademark of the European Community. ISM GRP 1-A denotes the instrument is an Industrial Scientific and Medical Group 1 Class A product. ICES/NMB-001 indicates product compliance with the Canadian Interference-Causing Equipment Standard.
MAINS ISOLATED	IEC Measurement Category MAINS ISOLATED is for measurements performed on circuits not directly connected to mains.
	KC certification mark to demonstrate compliance with the South Korean EMC requirements. South Korean Class A EMC declaration: This equipment is Class A suitable for professional use and is for use in electromagnetic environments outside of the home.

Symbol	Description
	A registered trademark of the Spectrum Management Agency of Australia. This signifies compliance with the Australia EMC Framework regulations under the terms of the Radio Communication Act of 1992.
	<p>This mark denotes compliance with the essential requirements of the following applicable UK regulations:</p> <ul style="list-style-type: none"> ▪ Electromagnetic Compatibility Regulations 2016 No. 1091 (as amended) ▪ Electrical Equipment (Safety) Regulations 2016 No. 1101 (as amended) ▪ The Restriction of the Use of Certain Hazardous Substances in electrical & Electronic Equipment Regulations 2012 No. 3032 (as amended)

Safety Circuit

Your Keysight isolated probe includes a safety circuit to protect you in case the fiber bundle is damaged. This circuit monitors the optical signal from the sensor and trips if the signal is lost.

The safety circuit may trip for non-hazardous reasons, such as a loss of power to the probe from the oscilloscope. If this happens, you may see a power-related warning message on the oscilloscope.

- 1 Remove the probe and inspect the fiber bundle for any damage.
- 2 If no damage is visible, reinsert the probe into the oscilloscope to reset the safety circuit.

If the circuit trips semi-frequently, clean the contacts of the AutoProbe I connector on the oscilloscope and the probe pins (see **"Cleaning the AutoProbe I Interface and Probe Pogo Pins"** on page 70):

- 1 Power down the oscilloscope.
- 2 Use isopropyl alcohol and a cotton swab to clean the contacts and pins.

Mesures de sécurité et avertissements

Ces produits ont été conçus et testés conformément aux normes reconnues de l'industrie et ont été fournis dans un état sans danger. La documentation contient des informations et des avertissements qui doivent être suivis par l'utilisateur pour garantir un fonctionnement en toute sécurité et pour maintenir ces produits dans un état sans danger.

AVERTISSEMENT

Si l'ensemble de sonde est utilisé d'une manière non spécifiée par le fabricant, la protection fournie par celui-ci peut être altérée.

AVERTISSEMENT

N'essayez pas de retirer les revêtements de la tête du capteur et du câble ou de démonter le produit. Ces sondes sont équipées de sources laser. L'exposition de ces sources peut vous exposer au risque d'exposition au rayonnement laser.

AVERTISSEMENT

Inspectez périodiquement les fils et les câbles de la sonde. Ne pas utiliser avec des dommages visibles/suspects. Si vous suspectez un dommage, faites-le inspecter par un personnel de service agréé Keysight.

AVERTISSEMENT

N'installez pas de pièces de rechange et n'effectuez aucune modification non autorisée sur la sonde/l'accessoire. Ne tentez pas d'entretien ou de réglage interne. Ces sondes ne sont pas réparables. Si la sonde est défectueuse, elle doit être rendue inopérante et renvoyée au bureau de vente Keysight. Voir "[Contacting Keysight Technologies for Technical Assistance](#)" on page 75 pour en savoir plus.

AVERTISSEMENT

**Doit être mis à la terre
Avant de connecter le connecteur de sortie de la sonde à une entrée de voie de l'oscilloscope, assurez-vous que l'oscilloscope est correctement mis à la terre.**

AVERTISSEMENT

**Utilisation en intérieur uniquement.
Ne pas utiliser dans des environnements mouillés/humides. Gardez les surfaces du produit sèches et propres.**

AVERTISSEMENT

N'utilisez pas la sonde ou l'oscilloscope en présence de gaz ou de fumées inflammables. L'utilisation de tout instrument électrique dans un tel environnement pose un danger pour la sécurité.

ATTENTION

Ne pas tordre, tirer ou plier la fibre optique de la sonde afin d'éviter de stresser les fibres optiques.

Lorsque vous pliez le câble à fibre optique de la sonde, évitez les coudes serrés et les angles vifs qui pourraient endommager le câble. Le rayon de courbure minimum du câble est de 2,5 pouces (63,5 mm) et le plus petit diamètre de boucle est de 5 pouces (127 mm).

ATTENTION

Lorsqu'elle n'est pas utilisée, conservez la sonde et ses accessoires dans la mallette du produit.

ATTENTION

Ne bloquez pas le conduit d'aération du ventilateur situé sur le boîtier de la sonde.

Procédures de sécurité lors de la connexion à un circuit

AVERTISSEMENT



Prévention des brûlures RF/chocs électriques potentiels
Dégagement minimal requis pour effectuer des mesures
Comme ces sondes prennent en charge les mesures en mode commun haute fréquence/haute tension, il est crucial de respecter les exigences de dégagement pour assurer l'isolation des tensions d'entrée dangereuses.

Vous devez rester à au moins 1 mètre de tous les côtés de la tête de capteur de la sonde et du câble de la pointe de la sonde chaque fois que la sonde est connectée à un circuit de test sous tension.

AVERTISSEMENT



Assurez-vous que le circuit de test est hors tension avant de connecter la pointe de la sonde au circuit de test et avant de déconnecter la pointe de la sonde du circuit de test.

AVERTISSEMENT**Observer les tensions nominales de la sonde et des embouts**

N'appliquez aucun potentiel électrique à l'entrée de la sonde qui dépasse la valeur nominale maximale de la sonde et de la pointe. Voir "**Electrical Specifications and Characteristics**" on page 16 pour les tensions d'entrée maximales.

Ces ensembles de sondes ne sont **PAS** destinés aux mesures sur des circuits directement connectés au secteur (c'est-à-dire des circuits CAT II, CAT III ou CAT IV).

Certification laser

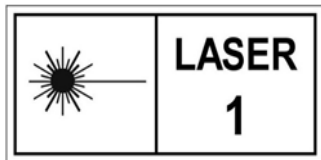



PRODUIT LASER DE CLASSE 1

Système laser de classe 1 dans des conditions « d'utilisation normale »
Conforme aux normes IEC 60825-1:2014 pour les systèmes laser.

Symboles de sécurité et de réglementation

Symbol	Description
	Le produit est marqué de ce symbole lorsqu'il est nécessaire pour l'utilisateur de se référer aux instructions de la documentation.
	Avertissement Haute tension - Possibilité de choc électrique
	Ces sondes sont des dispositifs sensibles aux décharges électrostatiques (ESD), en particulier au niveau de l'amplificateur de la sonde. Suivez les précautions ESD standard lors de leur manipulation.
	Ce symbole indique la période d'utilisation de protection de l'environnement (EPUP) pour les substances toxiques du produit pour les exigences RoHS de la Chine.
	Le symbole de la poubelle à roulettes barrée indique qu'une collecte séparée des déchets d'équipements électriques et électroniques (DEEE) est requise, comme l'exige la DIRECTIVE DE L'UE et d'autres législations nationales. Veuillez consulter keysight.com/go/takeback pour comprendre vos options d'échange avec Keysight en plus des instructions de reprise du produit.
 CAN ICES/NMB-001(A) ISM GRP 1-A	Le marquage CE est une marque déposée de la Communauté européenne. ISM GRP 1-A indique que l'instrument est un produit industriel, scientifique et médical du groupe 1 de classe A. ICES/NMB-001 indique la conformité du produit à la norme canadienne sur les équipements causant des interférences.
MAINS ISOLATED	La catégorie de mesure IEC MAINS ISOLATED est destinée aux mesures effectuées sur des circuits non directement connectés au secteur.
	Marque de certification KC pour démontrer la conformité aux exigences CEM sud-coréennes. Déclaration CEM de classe A sud-coréenne : cet équipement est de classe A adapté à un usage professionnel et est destiné à être utilisé dans des environnements électromagnétiques en dehors de la maison.

Symbol	Description
	<p>Une marque déposée de l'Agence de gestion du spectre d'Australie. Cela signifie la conformité aux réglementations australiennes EMC Framework en vertu de la Radio Communication Act de 1992.</p>
	<p>Cette marque indique la conformité aux exigences essentielles des réglementations britanniques applicables suivantes:</p> <ul style="list-style-type: none"> ▪ Règlement sur la compatibilité électromagnétique 2016 n° 1091 (tel que modifié) ▪ Règlement n° 1101 sur les équipements électriques (sécurité) de 2016 (tel que modifié) ▪ Règlement n° 3032 de 2012 sur la restriction de l'utilisation de certaines substances dangereuses dans les équipements électriques et électroniques (tel que modifié)

Cleaning the Probe and its Parts/Accessories

If the probe requires cleaning:

- 1 Disconnect the probe from the oscilloscope and the DUT.
- 2 Clean the external parts of the probe with a soft dry cloth or if needed, with one slightly dampened with mild soap and water solution.

CAUTION

Do not use too much liquid to avoid damaging sensitive electronic components.
Do not attempt to clean internally.

- 3 Make sure the probe is completely dry before reconnecting it to the oscilloscope.





Cleaning the AutoProbe I Interface and Probe Pogo Pins

NOTE

You must perform this procedure even if you are using a brand new oscilloscope.

Table 9 lists the materials required to perform the cleaning procedure. The brands shown in the table are examples only. You may use any brand of these materials locally available to you.

Table 9 List of cleaning materials

Material	Images of materials (examples)
Isopropanol (IPA)	
Lint-free wipes	
Lint-free swabs	
Duster spray	

Cleaning the AutoProbe I Pockets and Pads on the Oscilloscope

CAUTION

Turn off the oscilloscope before you start the cleaning procedure.

- 1 Apply IPA to a swab.

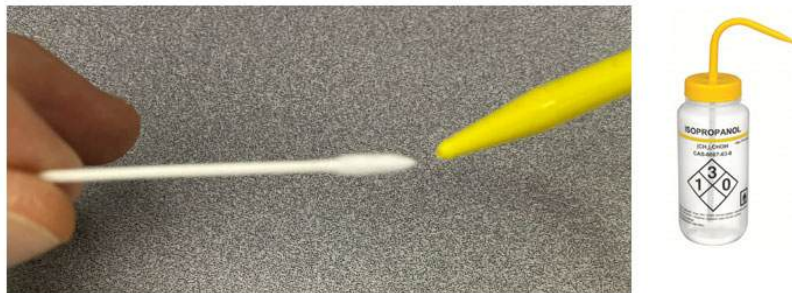

Figure 28 Applying IPA to swab

- 2 Swirl the IPA saturated swab around several times to ensure proper cleaning is done in each of the nine AutoProbe I pockets.

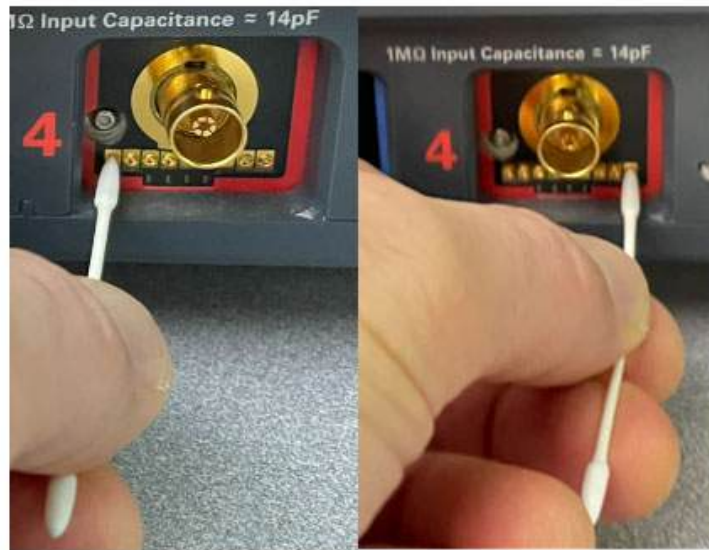

Figure 29 Cleaning pockets with IPA-saturated swab

- 3 Repeat this process using two to three swab ends to ensure thorough cleaning of the pads.
- 4 Apply IPA to a wipe.
- 5 Use the IPA saturated wipe to clean each of the nine AutoProbe I pads several times.



Figure 30 Cleaning pads with IPA-saturated wipe

- 6 Repeat this process using two to three swab ends to ensure thorough cleaning of the pads.
- 7 Spray the pockets and pads with a duster to eliminate any remaining dust.



Figure 31 Spraying with duster

Cleaning the Probe Pogo Pins

- 1 Use an IPA-saturated wipe to clean the ends of the pogo pins of the probe.
- 2 Wipe each pogo pin end carefully to ensure no residue remains.



Figure 32 Cleaning probe pogo pins with IPA-saturated wipe

4 Safety and Regulatory Information

5 Returning the Probe

WARNING

Do not install substitute parts or perform any unauthorized modification to the probe. Only Keysight approved accessories should be used.

If the probe is defective and needs to be returned, perform the following steps before shipping the probe back to Keysight Technologies.

- 1 Contact your nearest Keysight sales office for any additional details.
- 2 Write the following information on a tag and attach it to the malfunctioning equipment.
 - Name and address of owner
 - Product model number (for example, PS0004A)
 - Product Serial Number (for example, MYXXXXXXXX)
 - Description of failure or service required

NOTE

Include accessories shipped with the probe.

- 3 Protect the probe by wrapping in plastic or heavy paper. Use original packaging or comparable.
- 4 Pack the probe in the original carrying case or if not available, use bubble wrap or packing peanuts.
- 5 Place securely in a sealed shipping container and mark container as "FRAGILE".

If any correspondence is required, refer to the product by serial number and model number.

Before returning an instrument, you must first call the Keysight Call Center.

Contacting Keysight Technologies for Technical Assistance

For technical assistance, contact your local Keysight Call Center.

- In the Americas, call 1 (800) 829-4444
- In other regions, visit <http://www.keysight.com/find/assist>

Index

A

adapter, 14
additional accessories, 10
Autoprobe I, 13
AutoProbe I interface, 8

B

bend radius, 61
Bipod, 9

C

cleaning, 70
clearance, 61

F

fan, 61
fiber optic cable, 61

I

Infiniium oscilloscopes, 14
Infiniium software version, 14

L

laser, 62
loop diameter, 61

O

optical isolation, 6

P

performance test record, 57
performance verification, 47
PS0013A, 39

R

RF burns, 61

S

safety information, 60
SMA wrench, 9
software, 14

V

ventilation holes, 61

