

WireXpert MP - User Manual



© 2025 Softing Singapore Pte. Ltd.

Version 1.9.5

dataTec

Mess- und Prüftechnik. Die Experten.

Ihr Ansprechpartner /
Your Partner:

dataTec AG
E-Mail: info@datatec.eu
>>> www.datatec.eu

1. Disclaimer	4
1.1 Safety Precaution	5
1.2 Intended Use	5
1.3 About this document	6
1.4 Conventions Used	6
2. About Product	7
2.1 Scope of Delivery	10
2.2 Product Specifications	11
2.3 Product Overview	13
2.4 Battery Information	16
2.5 PC Software and Device Firmware	18
2.6 Cabling Certification and Testing	19
2.7 General Product Maintenance and Care Guide	21
3. Understanding the Product	23
3.1 Graphical User Interface Overview	24
3.2 Slide-down Menu	25
3.2.1 User Manager	26
3.2.2 System Settings	31
3.3 Copper Connection Status	43
3.4 Project, Site & Data	43
3.4.1 Project	44
3.4.2 Site	49
3.4.2.1 Label Source	53
3.4.3 Link Information	56
3.4.4 Data	56
3.5 Test Settings	60
3.6 Tools	69
3.6.1 Camera	71
4. Using the Product	74
4.1 Setting Reference	74
4.2 Performing an Autotest (WIP camera function)	76
4.3 Understanding the Results	79
4.4 Managing test result(s)	84
5. Technical Support	86

1 Disclaimer

The information contained in these instructions corresponds to the technical status at the time of printing of it and is passed on with the best of our knowledge. The information in these instructions is in no event a basis for warranty claims or contractual agreements concerning the described products, and may especially not be deemed as warranty concerning the quality and durability. We reserve the right to make any alterations or improvements to these instructions without prior notice. The actual design of products may deviate from the information contained in the instructions if technical alterations and product improvements so require.

It may not, in part or in its entirety, be reproduced, copied, or transferred into electronic media.

Softing Singapore Pte. Ltd.

73 Science Park Drive
#02-12/13 Cintech I
Singapore Science Park 1
Singapore 118254
<https://itnetworks.softing.com>



+ 65 6569 6019



+ 65 6899 1016



asia-support.itnetworks@softing.com

The latest version of this manual is available in the Softing download area at <https://itnetworks.softing.com/>.



**Ihr Ansprechpartner /
Your Partner:**

dataTec AG

E-Mail: info@datatec.eu

>>> www.datatec.eu

Mess- und Prüftechnik. Die Experten.

1.1 Safety Precaution



Read this manual before starting

For damages due to improper connection, implementation or operation Softing refuses any liability according to our existing warranty obligations.



Note

This symbol is used to call attention to notable information that should be followed during installation, use, or servicing of this device.



Hint

This symbol is used when providing you with helpful user hints.



CAUTION

Selection of option may cause all or partial of saved data and/or settings in the device to be erased or restored to non-reversible original factory state. Backing up of saved result(s) is recommended before executing option.



CAUTION

CAUTION indicates a potentially hazardous situation which, if not avoided, may result in minor or moderate injury.



Warning

WARNING indicates a potentially hazardous situation which, if not avoided, could result in death or serious injury



DANGER

DANGER indicates an imminently hazardous situation which, if not avoided, will result in death or serious injury. This signal word is to be limited to the most extreme situations.

1.2 Intended Use

The WireXpert MP series has been designed for use in factory, process and building control. The unit must not be used in explosion hazard areas. The permissible ambient conditions given in the Technical Data must be complied with.

The faultless and safe operation of the product requires proper transport, proper storage and installation, and expert operation and maintenance in accordance with the manual.

1.3 About this document



Read this manual before starting

For damages due to improper connection, implementation or operation Softing refuses any liability according to our existing warranty obligations.

1.4 Conventions Used

The following conventions are used throughout Softing customer documentation:

Keys, buttons, menu items, commands and other elements involving user interaction are set in bold font and menu sequences are separated by an arrow	Open Start → Control Panel → Programs
Buttons from the user interface are enclosed in brackets and set to bold typeface	Press [Start] to start the application
Coding samples, file extracts and screen output are set in Courier font type	MaxDlsapAddressSupported=23
Filenames and directories are written in italic	Device description files are located in C: \ <i><product name></i> \delivery\software\Device Description files

The following conventions are used in conjunction with products, accessories and procedures mentioned in this documentation:

Action verb	When performed on/with	Example
Tap	Touchscreen	Tap [Back] to return to the previous screen Tap the [Okay] button to proceed
Tap & hold	Touchscreen	Tap and hold selection seconds to multiple select
Swipe	Touchscreen	Swipe right to view the next page
Slide	Touchscreen	Slide the slider to increase brightness
Select	Touchscreen	Select the radio/checkbox/option
Pinch	Touchscreen	Pinch to zoom out the plot
Stretch	Touchscreen	Stretch to zoom in the plot
Press	Physical button	Press the [Home] button

Action verb	When performed on/with	Example
Press & hold	Physical button	Press and hold the button
Click	Mouse	Click the [Okay] button
Attach/Detach	Test Module/Test adapter	Attach the copper module to the mainframe Detach the Channel adapter from the copper module
Connect/Disconnect	Cable to connecting interface	Connect one end of the cable to the RJ45 port on the device Connect the SC connector to the coupler Disconnect the USB cable from the USB port

2 About Product

WireXpert MP is Softing’s next-generation evolution of the flagship WireXpert certifier. This advanced measurement tool now certifies structured copper cabling up to 3,000 MHz and introduces the new capability of quad-mode fiber optic certification thanks to its redesigned measurement module.

The device's enhanced modular design, consisting of a Mainframe, Test Module, and Test Adapter (for copper), allows for easy customization and scalability to adapt to evolving needs and technological advancements, making it a future-proof investment. The enhanced **Dual Control System Plus (DCS+)** now adds additional features to the dual touchscreen, including dual Autotest buttons, Flip-tag, a built-in camera, and the ability to view test results in landscape mode—all designed to optimize the certification process with unmatched efficiency.

WireXpert MP includes two identical units, LOCAL and REMOTE, for dual-ended testing and certification. The DCS+ ensures that both the LOCAL and REMOTE units display the same graphical data in real-time, significantly enhancing efficiency and productivity by allowing test data and settings to be viewed from either side.

In the event of a wire map failure, the DCS+ enables the operator at the far end to visually identify which specific wire pair is causing the error, along with the corresponding measurement parameters, rather than just relying on a basic LED indication as with traditional testers.

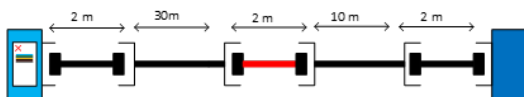

Traditional tester with single display screen, usually on LOCAL unit only

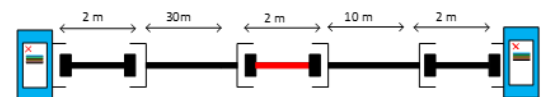

WireXpert MP with LCD screens display on both LOCAL and REMOTE units

WireXpert MP is available in several variants to offer flexibility for your certification needs: WireXpert MP C6A (up to 600 MHz), WireXpert MP C8 (up to 3,000 MHz), and WireXpert MP FQ for single and multimode fiber optics. The WireXpert MP C6A variant provides an affordable solution that can evolve with your certification requirements—upgrade

to WireXpert MP C8 when your needs extend beyond CAT 6A. The WireXpert MP FQ offers a complete fiber optic certification solution within a single module platform.

At Softing IT Networks, not only do we design testers that perform fast and accurate results, we build measurement tools that improve user experience and productivity.

Optimize!

Key differences between WireXpert MP series

Features	WireXpert MP C8	WireXpert MP C6A	WireXpert MP FQ
Frequency of measurement	3,000 MHz	600 MHz	-
Accuracy Specification	Exceeds: IEC 61935-1 Level IIIe, IV, V, VI; IEC 61935-1-1; IEC 61935-1-2; TIA 1152A Level IIIe, 2G; TIA-5071; draft ISO/IEC 61935-4	Exceeds: IEC 61935-1 Level IIIe, IV; IEC 61935-1-1; IEC 61935-1-2; TIA 1152A Level IIIe; TIA-5071; draft ISO/IEC 61935-4	IEC 14763-3, IEC 61280-4-1, IEC 61280-4-2
CAT 6A and below testing options	Yes	Yes	No
Class FA/CAT 8 options	Yes	No	No
SM Fiber Testing option	-	-	Yes
MM Fiber Testing option	-	-	Yes

Calibration

Softing recommends WireXpert MP to be calibrated annually. The devices will remind the user to calibrate the units if the last calibration was more than one year ago. This notification can be closed by tapping the **[Okay]** ✓ button, but will be displayed on every boot up until the units are calibrated.

Calibration data are stored in the Test Module and is not transferable when swapping between Mainframes.

Calibration is not required upon upgrading via license keys or swapping between Mainframes.

Calibration can only be done by the service center. Please contact your local sales representative for more information.

Serial Numbers

Each main component of the WireXpert MP has a unique serial number. The serial numbers can be found on the label at rear of the Mainframe, Test Module and Test Adapter. The serial numbers can also be found in **System Settings** → **Device Information** when the respective component are attached to the Mainframe.

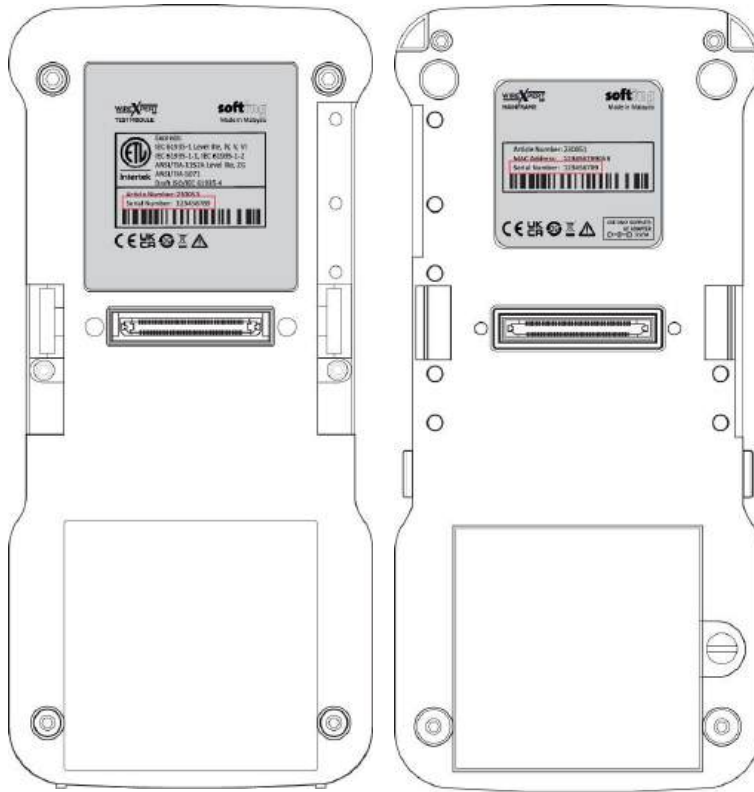

Rear view of the Mainframe

Rear view of the Test Module



Rear view of the Test Adapter

2.1 Scope of Delivery

A standard WireXpert MP C8 or WireXpert MP C6A kit comprises the following parts:



Tri-mode Soft Carrying Case
230058, Qty: 1



WireXpert MP Mainframe
units
230051, Qty: 2



Copper Measurement Test
Modules
230053 or 230052, Qty: 2



Channel Test Adapters
230071 or 230054, Qty: 2



Permanent Link Test Adapters
230072 or 230055, Qty: 2



Longlife Test/Reference Cords
230069, Qty: 2



Power Supply Adapters
230066, Qty: 2



Adjustable neck/shoulder
sling
230068, Qty: 2



Wired Headsets
230065, Qty: 2

- Calibration & conformance certificates, Qty: 1 set



DCRU Calibration Artifact
230070, Qty: 1



2.2 Product Specifications

Parameters	Specifications	
	WIREXPRT MP C6A	WIREXPRT MP C8
COPPER TESTING		
Accuracies	Exceeds: IEC 61935-1 Level IIIe, IV; IEC 61935-1-1; IEC 61935-1-2; TIA 1152A Level IIIe; TIA-5071; draft ISO/IEC 61935-4	Exceeds: IEC 61935-1 Level IIIe, IV; IEC 61935-1-1; IEC 61935-1-2; TIA 1152A Level IIIe; TIA-5071; draft ISO/IEC 61935-4
Certification testing	TIA 568.2-E CAT 5e, 6, 6A, TIA 1005A, TIA 568.5, TIA 568.7; ISO/IEC 11801 series and EN 50173 Class D, E, E A, F; TIA and ISO testing modes: Permanent link, channel, MPTL, E2E; Patchcord testing Cat 5e, 6, 6A, 7	TIA 568.2-E CAT 5e, 6, 6A, CAT 8, TIA 1005A, TIA 568.5, TIA 568.7; ISO/IEC 11801 series and EN 50173 Class D, E, EA, F, FA, Class I and Class II; TIA and ISO testing modes: Permanent link, channel, MPTL, E2E; Patchcord testing Cat 5e, 6, 6A, 7, 7A, 8
Max. cable length for dual-ended Autotest	Measurement range: 0 - 2000m, display resolution: 0.1m	
Insertion cycles Channel:	Channel: 10000 typical, Permanent link: 5000 typical	
TEST PARAMETERS		
Wiremap	TIA 568A and 568B, crossover variants, Profinet	
Loop Resistance	Measurement range: 0 - 200 Ohm, display resolution: 0.1 Ohm	
Length	0 - 2000 m, display resolution: 0.1 m	
Propagation Delay and Delay Skew	Measurement range 1 ns – 10 µsec, display resolution: 1 ns	
RF Parameter Display Resolution	0.1 dB	
Advanced diagnostics	Time-domain fault Locator for RL and NEXT	
GENERAL SPECIFICATIONS		
Interfaces	4x USB host, 1x USB device, 1x DC power jack, 1x 3.5mm audio jack, 1x RJ45 Ethernet jack	
Display	5.5" industrial LCD, projected capacitive touch sensitive area on both units	
Camera	Single 5MP, f/2.2, 89 degree FOV, integrated with single white LED	
Sensority	Built-in accelerometer for screen orientation	

Parameters	Specifications
Enclosure	Ruggedized plastic with rubber over-mold and rubber dust covers
Remote unit abilities	View test results, save tests, start autotest
Power supply	AC 100-240V to 12V; 3A power adapter
Battery	7.2V, 6.7Ah; removable and rechargeable Li-Ion
Operating time with batteries	8 hours continuous operation
Internal storage capacity	2,500MB or > 10,000 test results (excluding images)
External storage	USB Flash Drive
Dimensions	260mm x 120mm x 55mm
Weight	Approx. 1.1kg (incl. battery)
Supported languages	EN, DE, FR, ES , IT
Calibration period	1 year
ENVIRONMENTAL	
Operating temperature	0 to 40°C
Storage temperature	-20 to 60°C
Relative humidity	10% to 80%
MINIMUM SYSTEM REQUIREMENTS FOR REPORTING SOFTWARE	
Microsoft Windows 10/11, 32 or 64bit	Intel Core i5, 2.4GHz and higher
500MB of free disk space	1GB RAM
Microsoft.NET Framework 4.0	

2.3 Product Overview



Part	Functionality												
FRONT VIEW													
[Power]  button	<p>To turn on the device, press and hold the power button for 2 seconds.</p> <p>To turn off the device, press and hold the power button for 2 seconds and select the [Okay] button to shutdown the device safely.</p> <p>To turn off the back-light without shutting down the device, press and release the power button quickly. Touch the screen or press the [Home] button to restore.</p> <table border="1"> <thead> <tr> <th>LED status:</th> <th>Description</th> </tr> </thead> <tbody> <tr> <td>Green</td> <td>The device is fully charged when the power supply is connected. The device is switched on, in battery mode.</td> </tr> <tr> <td>Red</td> <td>The device is switched off, charging.</td> </tr> <tr> <td>Red, blinking</td> <td>The device is switched off, battery removed, in AC power mode.</td> </tr> <tr> <td>Orange</td> <td>The device is switched on, charging.</td> </tr> <tr> <td>Orange-green, blinking</td> <td>The device is switched on, battery removed, in AC power mode. The device is switched on, battery in, power supply is connected while performing an Autotest.</td> </tr> </tbody> </table>	LED status:	Description	Green	The device is fully charged when the power supply is connected. The device is switched on, in battery mode.	Red	The device is switched off, charging.	Red, blinking	The device is switched off, battery removed, in AC power mode.	Orange	The device is switched on, charging.	Orange-green, blinking	The device is switched on, battery removed, in AC power mode. The device is switched on, battery in, power supply is connected while performing an Autotest.
LED status:	Description												
Green	The device is fully charged when the power supply is connected. The device is switched on, in battery mode.												
Red	The device is switched off, charging.												
Red, blinking	The device is switched off, battery removed, in AC power mode.												
Orange	The device is switched on, charging.												
Orange-green, blinking	The device is switched on, battery removed, in AC power mode. The device is switched on, battery in, power supply is connected while performing an Autotest.												
Touch Sensitive LCD screen	Performs configuration, test executions and viewing of results.												
[Home]  button	Returns device to the Home screen.												
FlipTag	Reversible tags changes unit to the LOCAL or REMOTE unit when flipped and reattached to the Mainframe. Function can be disabled in system settings.												
LEFT SIDE VIEW													
Audio port	Enables vocal communication between LOCAL and REMOTE units when connected to talk set headphones.												
Power Supply port	Performs charging of device when connected to power adapter shipped with WireXpert MP.												
AUTOTEST button (L)	Performs test based on the saved configuration and settings.												
RIGHT SIDE VIEW													
USB device port (1), (2)	Used only for the Wi-Fi and Bluetooth dongle as required for the respective connectivity.												
USB device port (3), (4)	Enables exporting of test results and importing of configuration files via USB memory sticks and other peripherals supported by the device.												
RJ-45 communication port	For development and debugging purposes only.												
AUTOTEST button (R)	Performs test based on the saved configuration and settings.												
Back view													

Part	Functionality
Module interface connector	When connected with different measurement modules, device will enable specified measurement test to be conducted.
Battery compartment	Battery storage compartment. Refer to Battery Information ¹⁶ for more information.
Top view	
Onboard camera	Built-in camera for taking snapshots for attaching to test reports.
Flash light	Light for dim or dark environment.

2.4 Battery Information

WireXpert MP units are powered by Lithium Ion rechargeable batteries. These batteries contain circuitry that reports their state of charge to the device. The devices can be powered by external AC/DC power supply adapters.

A fully charged battery can operate WireXpert MP for five to eight hours before requiring recharging. Reducing the screen brightness and enabling the sleep function allows the device to run longer on a charge.



WARNING

Do not set reference or operate WireXpert MP while the battery is hot immediately after charging.

Make sure that the WireXpert MP is always operated within the allowed temperature range from 0-40°C. If a significant increase or decrease of the temperature is discovered, repeat the set reference procedure to remain the instrument's accuracy



CAUTION

Use only the power supply adapters delivered with the WireXpert MP kit. Using other powers may damage the device and void its warranty.

Battery Safety

- To avoid the risk of fire, burns or damage to your battery pack, do not allow metal objects to touch the battery contacts.
- The battery pack is suitable for use only with compatible WireXpert MP devices.
- Do not disassemble the battery pack. There are no user serviceable parts inside. Do not dispose the battery pack in fire or water.
- Handle a damaged or leaking battery with extreme care. If you come into contact with the electrolyte, wash the exposed area with soap and water. If the electrolyte contacts the eye, flush the eye with water for 15 minutes and seek medical attention.
- Do not expose the battery pack to high storage temperatures (above 40°C).
- When discarding a battery pack, contact your local waste disposal provider regarding local restrictions on the disposal or recycling of Lithium Ion batteries.
- To obtain a replacement battery (230061), contact your local dealer.
- Do not charge the batteries pack if the ambient temperature is above 40°C.

Replacing Battery

1. Switch off WireXpert MP and disconnect external power supplies.

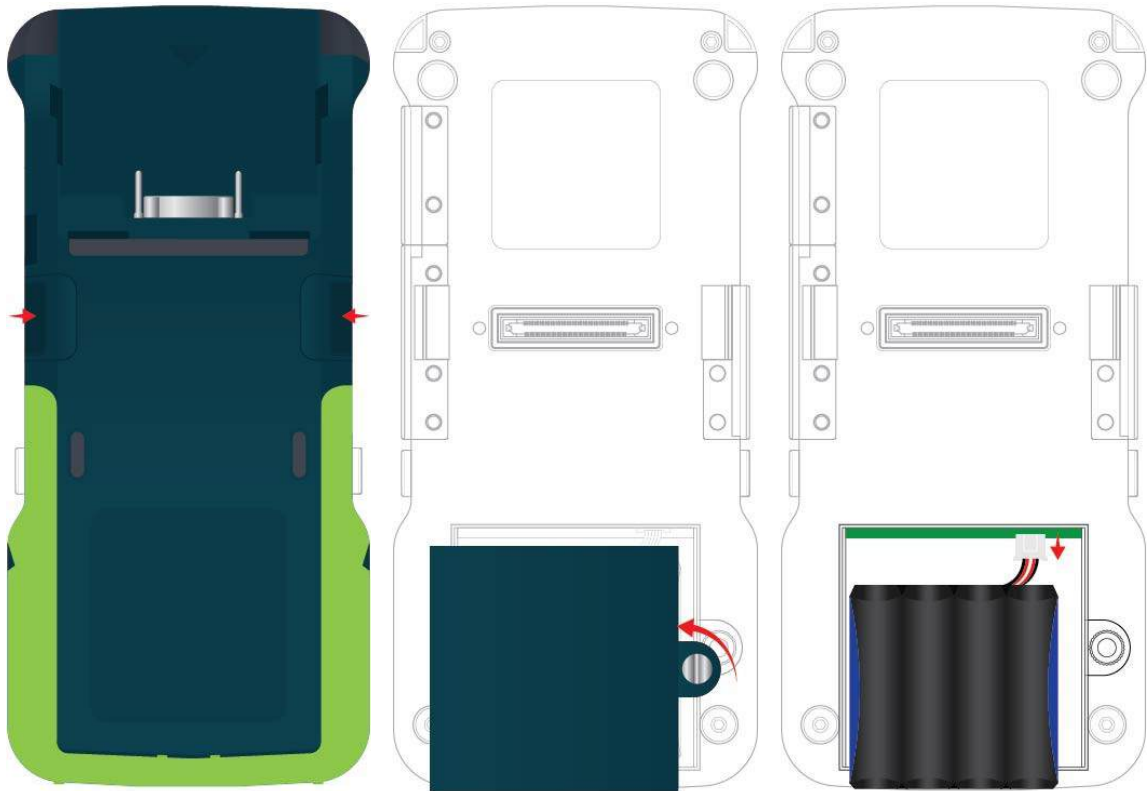

2. Detach the Test Module from the Mainframe.
3. Unlock the quarter-turn stud to remove the the cover of the battery compartment on the Mainframe.
4. Disconnect the connector from the device and remove the battery from the compartment.
5. After disconnecting the battery, press and release the power button to perform a power discharge.
6. Replace and connect new battery to the Mainframe.
7. Close the cover and lock the quarter-turn stud onto the Mainframe.



Note

There will not be any visible reaction when performing the power discharge. By performing the battery, any information from the previous battery will be erased and replaced with the new battery.



CAUTION

Use only the batteries supplied by Softing. Using other batteries may damage the device and void its warranty.

2.5 PC Software and Device Firmware

Minimum System Requirements for Reporting Software

- | | |
|---------------------------------------|-----------------------------------|
| ✓ Microsoft Windows 11, 32 or 64 bits | ✓ Intel Core i5, 2.4GHz or higher |
| ✓ 500MB of free disk space | ✓ 1GB RAM |
| ✓ Microsoft .NET Framework 4.0 | |

Install PC software

1. Download the latest eXport PC software from <https://itnetworks.softing.com/>
2. Run eXport setup v9.x.x64.exe
3. Follow through the instructions on the screen and click **[Next]** to proceed.
4. Click **[Install]** to begin installation.
5. Click **[Finish]** to complete installation.
6. If this is an upgrade from an earlier version from 6.x and above, click **[Yes]** to proceed.
7. Follow the instructions to complete installation.



Read this manual before starting

For more information on installation and using eXport PC software, please refer to “Installation Guide for eXport PC software” and “User Manual for eXport PC software”.

Update firmware

1. Download and install the latest eXport PC software.
2. Connect an USB flash drive to the workstation.
3. Run eXport PC software.
4. Go to **Tools** → **Update Device Firmware**
5. Click **[OK]** and select USB drive from “Export to USB” window.
6. Click **[Export]** and **[OK]** to proceed.
7. Please wait while exporting takes place. This process may take a while.
8. Remove USB flash drive from workstation and connect to WireXpert.
9. Select **[Upgrade Firmware]** from prompt and click **[OK]** button to continue.
10. If prompt did not appear, check that USB icon is present on the status bar. Tap the USB icon on the status bar or go to **System Settings** → **Storage** → **USB**.
11. Please wait while upgrading takes place. This process may take a while.

12. Firmware update is completed.



CAUTION

Saved test results and settings may be erased during upgrading. You are recommended to save all test results before upgrading the firmware.



Note

It is recommended to update both LOCAL and REMOTE units using the same firmware version.

2.6 Cabling Certification and Testing

Permanent Link

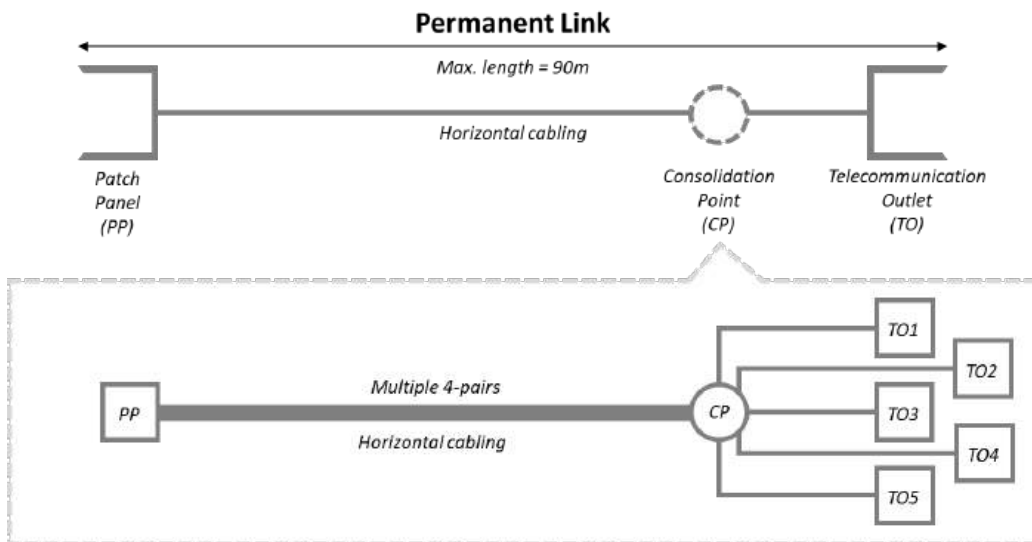

The Permanent Link configuration is generally used in facilities still under construction and does not include user patch cords. As the link configuration does not include the two additional connections of the patch cords, performance standards are more stringent. Special link adapters are used on both LOCAL and REMOTE units for links that are under test. The Permanent Link test adapters are delivered with the standard WireXpert MP kit.

Channel Link

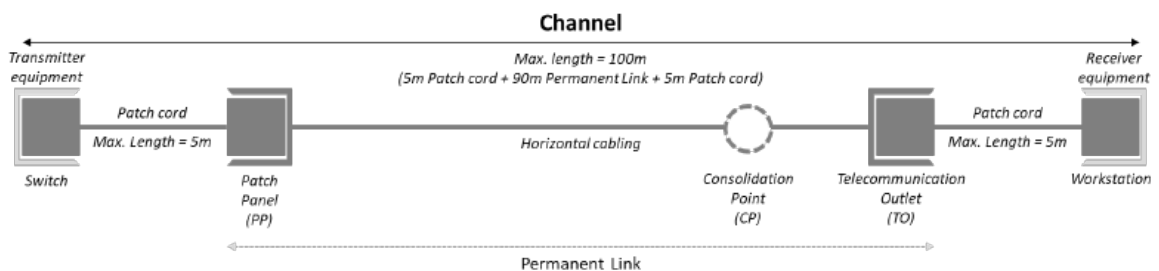

User patch cords are included for the Channel configuration. The pass/fail limits for this configuration allows performance degradation inherent in the two additional patch cords

included in the measurements, thus are less stringent. Special channel adapters are used on both LOCAL and REMOTE units for channels that are under test. The Channel test adapters are delivered with the standard WireXpert MP kit.

End-to-End (E2E) Link

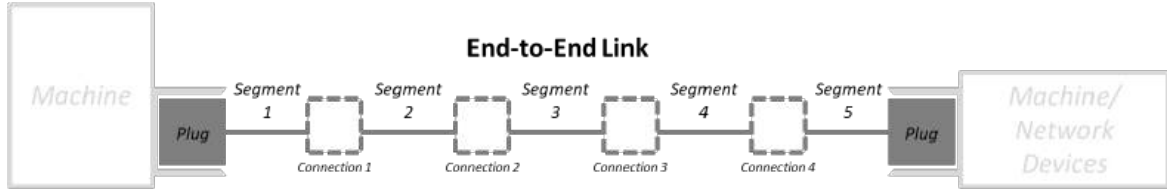

E2E links are applicable when application is required to connect directly to machines or machines to network devices. The E2E link test adapters are not delivered with the standard WireXpert MP kit.

Modular Plug Terminated Link (MPTL)

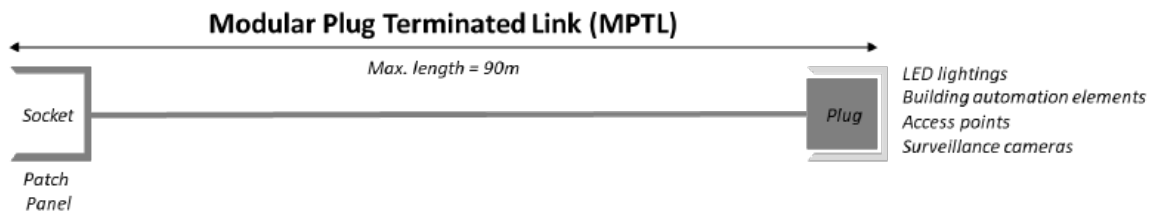

MPTL features a socket on the patch panel, and a plug on the opposite side of the link. The MPTL is similar to the E2E link, however, is used when IP-capable devices are permanently installed, e.g, LED lights, building automation elements or surveillance cameras. The installation cable is plugged directly into the termination device without the addition of a socket plus patch cable. A Permanent Link and a Patch Cord test adapter is required to perform the MPTL test. The Patch cord test adapter is not delivered with the standard WireXpert MP kit.

2.7 General Product Maintenance and Care Guide

This document contains general instructions and recommendations in performing maintenance and care for the product, accompanying and optional accessories.

Products and accessories are recommended to operate and stored under the conditions as stated in the Product Specifications.

Mainframe

- a) The touchscreen and all other parts of the main device are recommended to be cleaned with a soft cloth without any solvent.
- b) The Test Modules are recommended to be calibrated annually. Calibration can only be performed by authorized Service Centers. Please contact your local sales representative for more information.
- c) All electronic parts and components should not be dismantled and replaced. Any unauthorized repairs or modifications will void all warranties. Please contact your local sales representative for more information.

Battery

- a) Use only battery supplied by Softing for your devices.
- b) The battery in the device should be fully discharged and fully charged again should the device is planned for storage for an extended period, i.e., > 6 months.
- c) The battery in the device should be fully discharged and fully charged again after a long period of inactivity to allow reset of battery level measurements.
- d) If battery replacement is required, the user non-replaceable battery in the device will maintain the internal clock for 24 hours.

Copper Test Module & Adapter

- a) Recommended insertion cycles before replacement
 - Channel: 10,000 (typical)
 - Permanent Link: 5,000 (typical)
- b) Lint-free wipes or isopropyl alcohol may be used to remove oxidation residues on the copper contacts, e.g., the test adapter interface and connector port.
- c) Copper Test Modules are recommended to be calibrated annually. Calibration can only be performed by authorized Service Centers. Please contact your local sales representative for more information.

Fiber Optic Test Module

- a) Fiber optic end-face inspection for contamination to the patch cords, patch panels and equipment are recommended before performing any termination.
- b) Fiber optic end-face cleaning is recommended before performing any termination.
- c) Fiber optic Test Modules are recommended to be calibrated annually. Calibration can only be performed by authorized Service Centers. Please contact your local sales representative for more information.

Copper Permanent Link/Test Reference Cord

- a) Recommended insertion cycles before replacement: 750

Fiber Optic Reference Cord

- a) Fiber optic end-face inspection for contamination to the patch cords, patch panels and equipment are recommended before performing any termination.
- b) Fiber optic end-face cleaning is recommended before performing any termination.
- c) Ensure the patch cords are straight, without tension and refrained from sharp bends to prevent causing damage and/or additional losses to the cables.

AC Power Supply Adapter

- a) The power supply adapter should be protected from high temperature and moisture at all times.
- b) The power supply adapter should be used in a well-ventilated environment.

Warranty, extended warranty and XpertCare program

Softing provides a standard one-year warranty for manufacture defects. The warranty covers defects such as devices or accessories that have ceased to operate as intended that are not caused by mishandling or wear and tear. The standard warranty does not include calibration. An optional extended warranty can be purchased with each new purchase of the device.

Softing recommends calibrating WireXpert MP annually. The XpertCare program supports annual calibration and replacement of selected test accessories. Please contact your local sales representatives for more information.

For more information on Service Centers and technical support, please visit <https://itnetworks.softing.com/contact/>.

3 Understanding the Product

[Home]  button





The device can be navigated using the touchscreen and be returned to the Home screen by pressing the [Home]  button.

The AUTOTEST buttons

The AUTOTEST or Autotest buttons are located at both sides of the device, allowing left or right handed person to handle and operate the device more efficiently. The buttons can be configured to be active only when there it is connected to a far-end unit. Soft button only option is also available. Refer to [Auto-test Settings](#) ³¹ for more information.

By pressing either of the AUTOTEST button, the device will perform a certification test on the last configured settings. If no settings were configured, default settings will be used.

Test summary screen indicating the overall test result and individual parameters with the following symbols. More information of the test results can be viewed by selecting [View Details]  on the result screen.

	“PASS” – Good test result in accordance to pre-defined settings.
	Marginal “PASS” – “PASS” result with one or more test parameters that have margin in the range of uncertainty of the tester.
	“FAIL” – Unacceptable results with severe disturbance on one or more test parameters.
	Marginal “FAIL” – “FAIL” result with one or more test parameters that have negative margin in the range of uncertainty of the tester.
	For Information Only - Parameter is tested but not required for the selected test limit or configuration.

FlipTag

The FlipTag allows the user to swap a LOCAL unit to become a REMOTE unit by removing the tag from its dock, flip it over and place it back to the dock. This feature can be disabled from the **System Settings** → **Display Settings** → **Device Type**.

Onboard Camera

The onboard camera allows the user to take a snapshot of the test conditions as an optional attachment to the main test result. This feature can be selected from the TOOLS menu.

Landscape-view

Plots from AUTOTEST results can be viewed in the landscape orientation to maximize viewing. Rotate the device to switch between portrait and landscape view. Feature is only available on plots of AUTOTEST results, e.g., NEXT, Return Loss, ACRF, etc. This feature can be enabled from the **System Settings** → **Display Settings** → **Device Type**

3.1 Graphical User Interface Overview

On boot-up, the Home screen is divided into 6 sections.



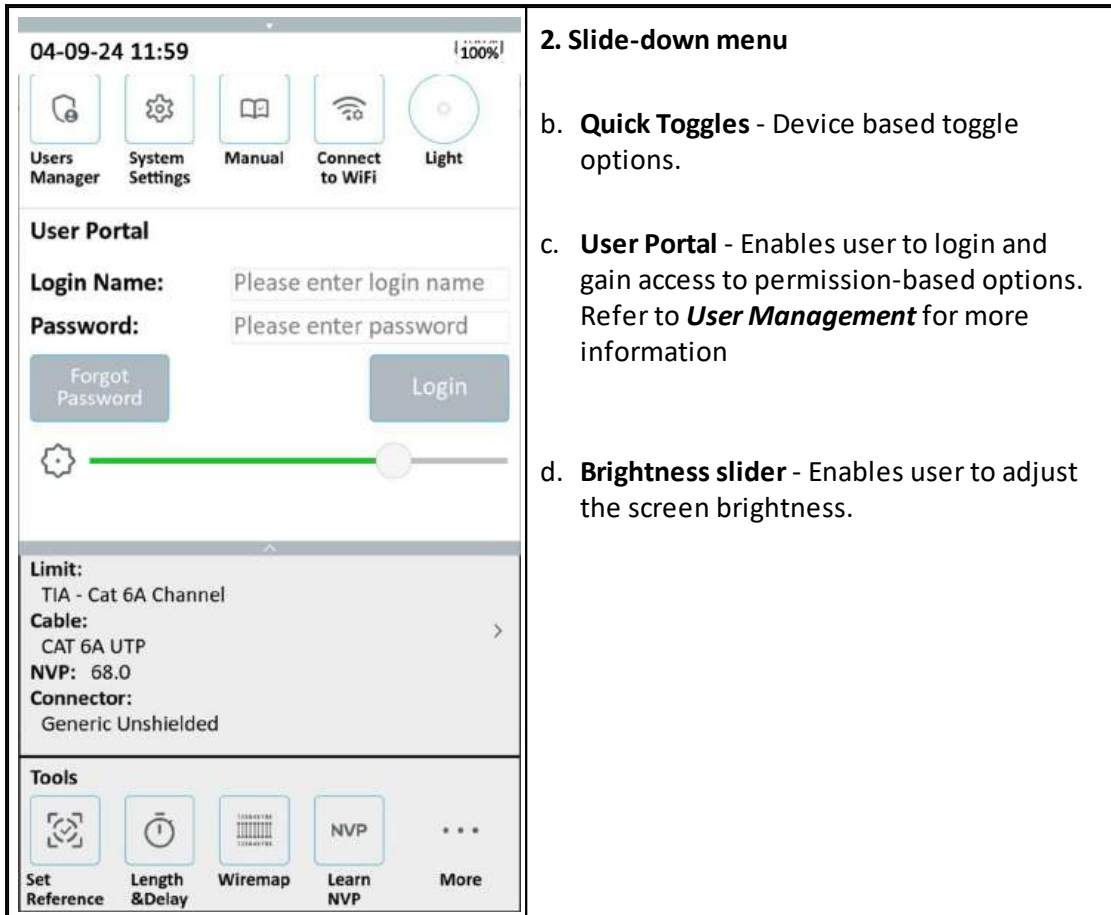

	<ol style="list-style-type: none"> 1. Slide-down menu 2. Status bar 3. Copper Connection Status 4. Project, Site and Data 5. Test Settings 6. Tools
--	---

1. The **Slide-down menu** can be triggered by performing a swipe-down action from the top of the screen. It provides quick accessible options to user and device configurations. Slide the menu upwards or press the **[Home]** button to hide menu.



2. Slide-down menu

- b. **Quick Toggles** - Device based toggle options.
- c. **User Portal** - Enables user to login and gain access to permission-based options. Refer to **User Management** for more information
- d. **Brightness slider** - Enables user to adjust the screen brightness.

- 2. The **Status bar** displays the current date & time, Wi-Fi connectivity status , USB connectivity status , device connectivity status  and battery level . Tap icons to change or view setting.
- 3. **Copper Connection Status** - Reports instantaneous wiremap reading when a LOCAL and REMOTE unit are connected.
- 4. **Project, Site & Data** - Project oriented configurations and information, such as site information and test results.
- 5. **Test Settings** - Test oriented configurations, such as cable and connector selection, test limits and options.
- 6. **Tools** - Advanced and single test applications.

3.2 Slide-down Menu

The Slide-down menu  provides quick accessible options to user and device configurations. This menu cannot be accessed during an AUTOTEST or at the result screen.

Quick Toggles



User Manager

The User Manager allows the device admin to add Technicians or Managers to the device. Refer to [User Manager](#) ²⁶ for more information.



System Settings

The System Settings provides device oriented configurations, such as display, time & date and power settings. Refer to [System Settings](#)³¹ for more information.



Manual

Select option to access the product User Manual.



Wi-Fi Settings

Tap to enter Wi-Fi configuration screen. External USB Wi-Fi dongle (230063) is required. Refer to Wi-Fi for more information.

Quick Toggles



Flashlight

Toggle option to enable or disable built-in LED flashlight located at the top of the Mainframe unit.

User Portal

The User Portal allow user to log-in as a Technician or Manager for permission based features.

Login Name must be a valid email address as credentials will be emailed to this mailbox when "Forgot Password" option is selected.

Password must be at in alphanumeric characters. Special or not English characters cannot be used.

3.2.1 User Manager



Users Manager

The User Manager allows the device admin to add Technicians or Managers to the device.



Display Settings

To add a user, from the Home screen



1. Pull down the Slide-down menu.
2. Select **[User Manager]**.
3. Tap **[Add] +**.
4. Enter **User Name** to create display name.
5. Enter **User Email**.
6. Enter **New Password**.

7. Enter password again to **Confirm Password** change.
8. Select
 - a. **[Technician]** account to allow the user to have limited configuration access to the device. The technician will only be able to access user and test related settings, including performing tests.
 - b. **[Manager]** account to allow the user to have full configuration access to the device, including system settings and management of users. The Project Manager will be able to manage projects and sites for Technicians.
9. Tap **[Okay]** ✓ to confirm, or **[Cancel]** ✕ to exit.



Note

An active Internet connection is not required to add a Technician or Manager user to the device. However, a working email is required for password recovery.



Note

A Manager account has been created by default. Login to that account to add another Manager. This account cannot be deleted for recovery purposes.

Please email asia-support.itnetworks@softing.com with your device serial numbers for the login credentials.



To find a User,



1. Tap **[Search]** 🔍.
2. Enter the user name to search.
3. Tap **[Okay]** ✓ to confirm, or **[Cancel]** ✕ to exit.



To edit a User,



1. Select user to be edited.
2. Tap **[Edit]** .
3. Enter **User Name** to change display name.
4. Enter **New Password** to change password.
5. Enter password again to **Confirm Password** change.
6. Select to change **User Type**.
7. Tap **[Okay]**  to confirm, or **[Cancel]**  to exit.

To delete a User,



1. Select user to be deleted.
2. Tap **[Delete]** .
3. Tap **[Okay]**  to confirm, or **[Cancel]**  to exit.

To delete multiple Users,

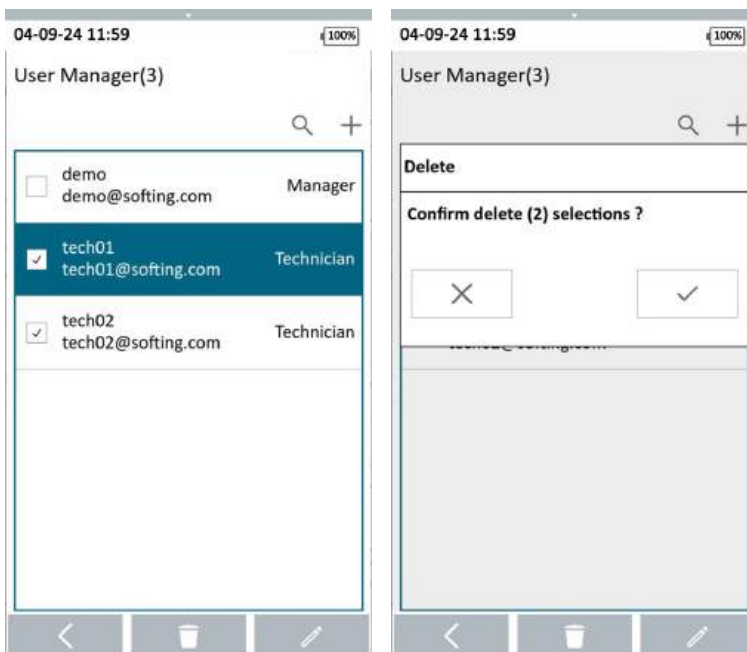

1. Tap and hold on a user to toggle multiple selections.
2. Select users to be deleted by selecting the check-boxes.
3. Tap **[Delete]** .

4. Tap **[Okay]** ✓ to confirm, or **[Cancel]** ✕ to exit.

3.2.2 System Settings

Display Settings Language

Select to change language. Tap **[Okay]** ✓ to save selection or **[Back]** < to exit Language selection.

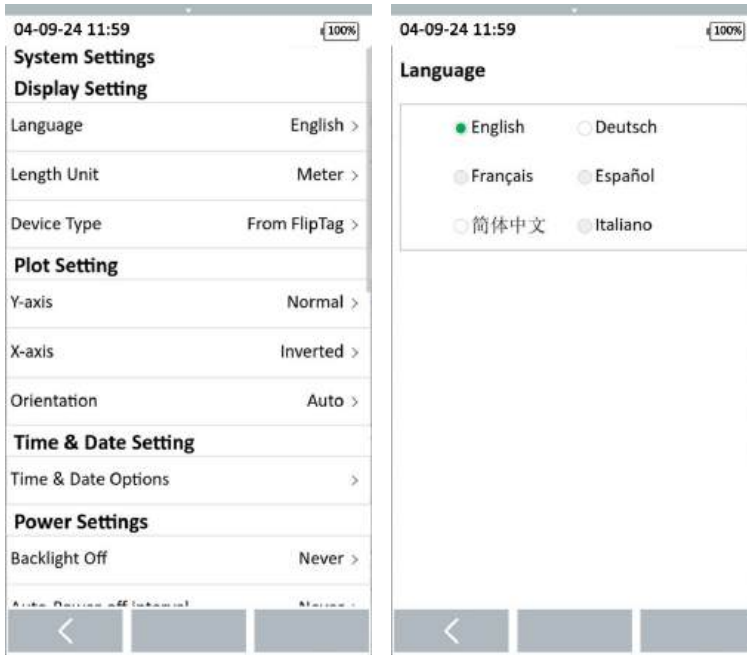

Display Settings

Language

Length Unit

Select the preferred length unit to be displayed. **Feet** (ft) and **Meters** (m) are available. Selection will be automatically saved.

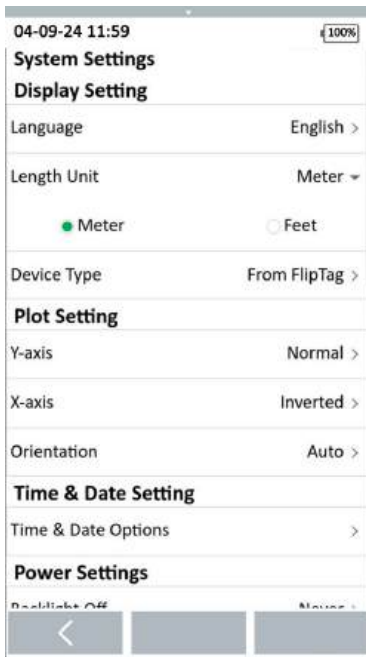

Length Unit

Device Type

Select to switch a LOCAL unit to REMOTE, or vice versa. Selecting the LOCAL or REMOTE option will disable the FlipTag. Device will reboot if REMOTE is selected while in LOCAL mode, or vice-versa.

Select [**From FlipTag**] to automatically switch sides based on the physical attachment of the FlipTag. Selection will be automatically saved. Device will require to reboot to take effect.

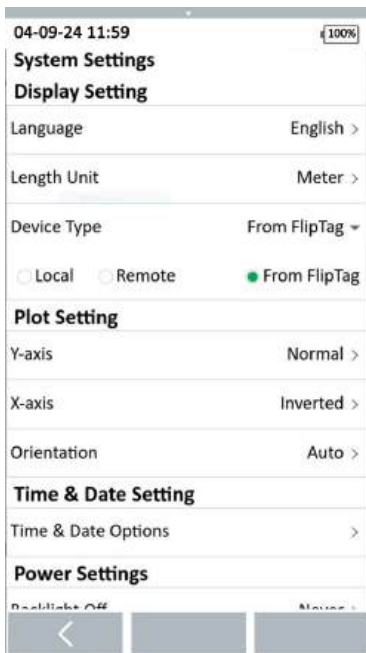

Device Type

Plot Settings

Y-axis

Select to select the how the plot's Y-axis will be display. **[Normal]** and **[Flipped]** Y-axis are available.

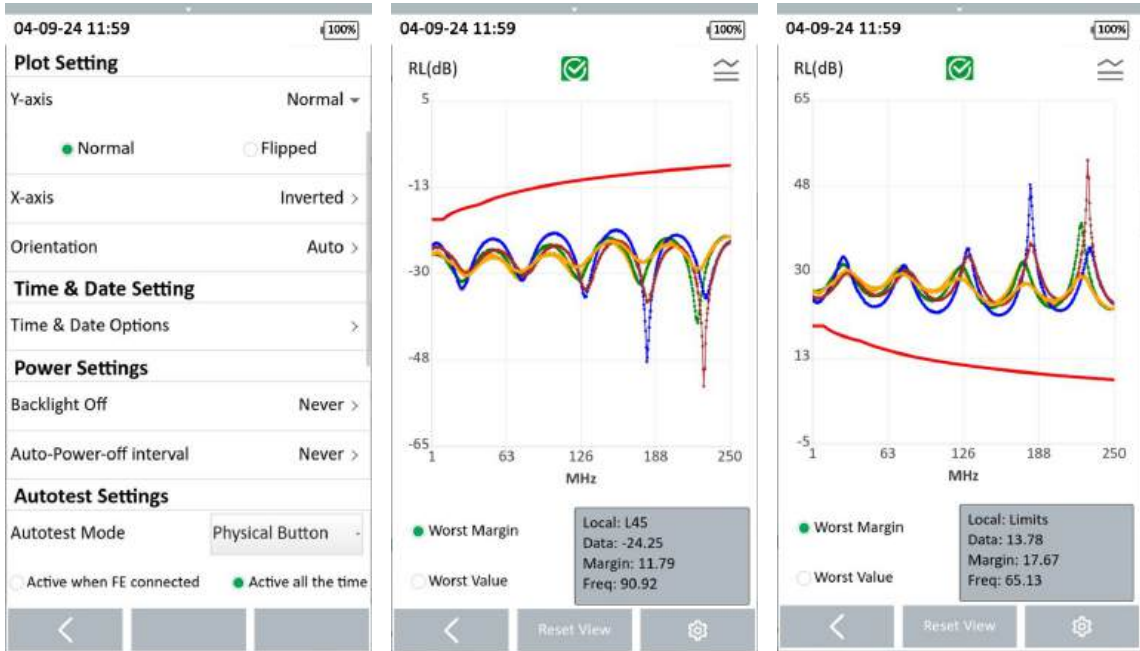

Plot Settings > Y-axis

Normal Y-axis plot

Flipped Y-axis plot

X-axis

Select to select the how the plot's X-axis will be display. **[Inverted]** and **[Log]** X-axis are available.

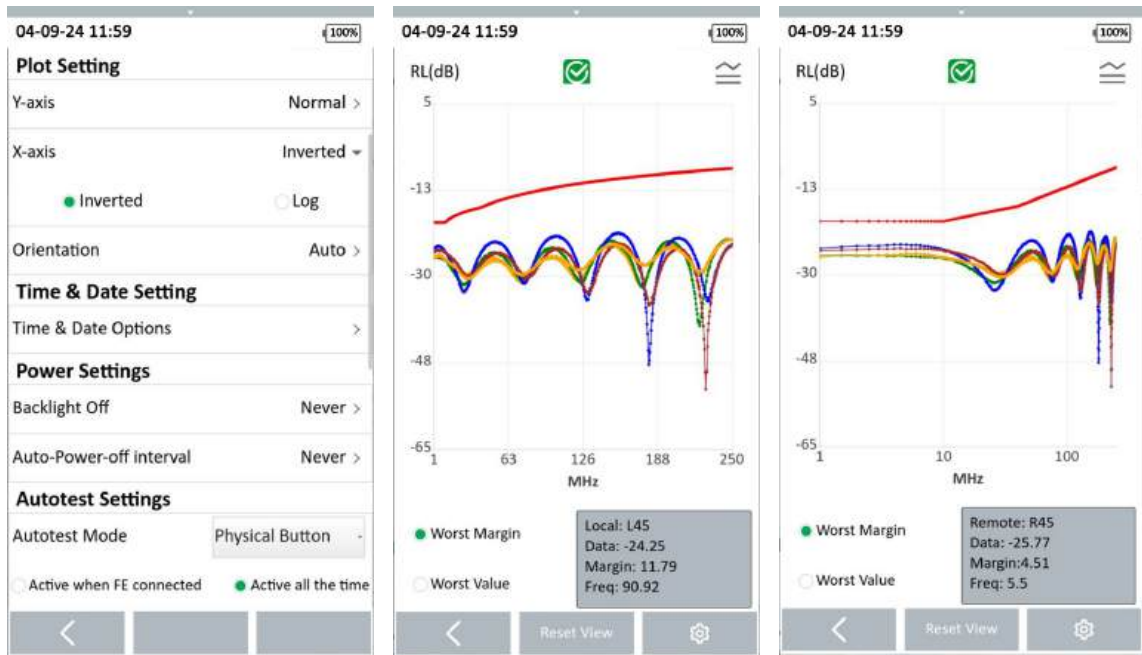

Plot Settings > X-axis

Inverted X-axis plot

Log-axis plot

Orientation

Select to enable device to view plots in landscape orientation when rotated. Select **[Auto]** to enable landscape view of plots by rotating the device and **[Portrait]** to disable rotation.

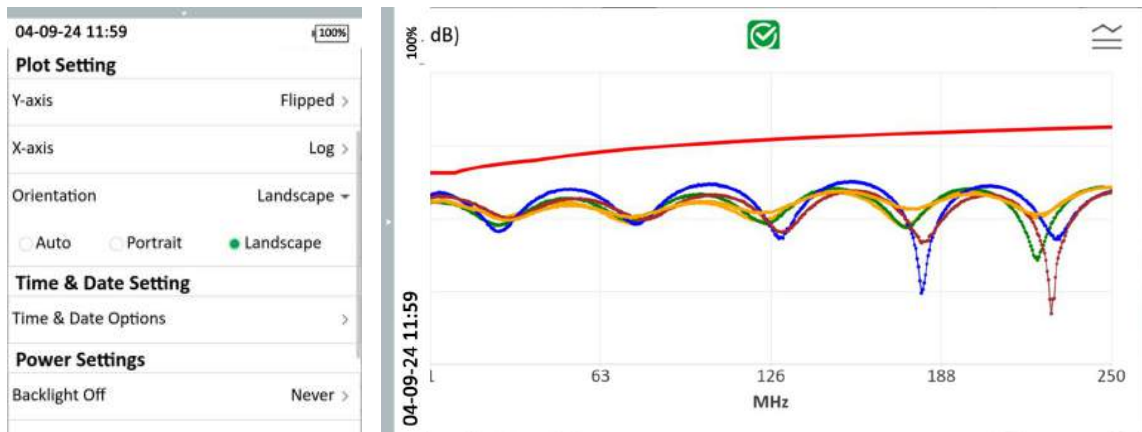

Landscape

Plot Settings > Orientation

Time & Date Settings

Time Zone

Select time zone from drop-down list.



Time & Date Settings



Time & Date Options

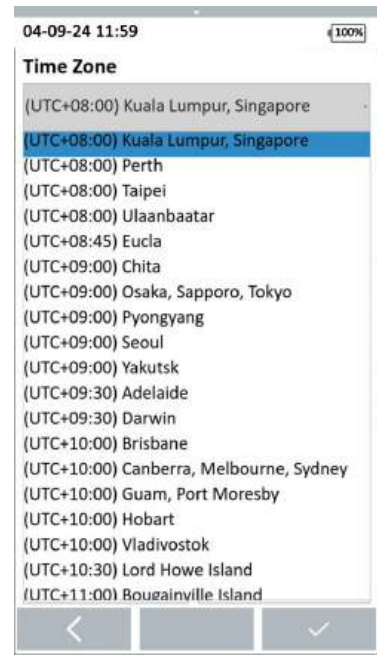

Time Zone

Date & Time

Select Year, Month and Date from the date picker.



Format > dd/mm/yyyy



Format > mm/dd/yyyy



Format > yyyy/mm/dd

Select

- dd/mm/yyyy to display date as date/month/year format, e.g., 31/12/2023 for 31st December 2023

- mm/dd/yyyy to display date as month/date/year format, e.g., 12/31/2023 for 31st December 2023
- yyyy/mm/dd to display date as year/month/date format, e.g., 2023/12/31 for 31st December 2023

Select **[Hour]** and **[Minutes]** from the time picker. **[AM]** and **[PM]** selection will not be available when **24-hour** clock format is selected.

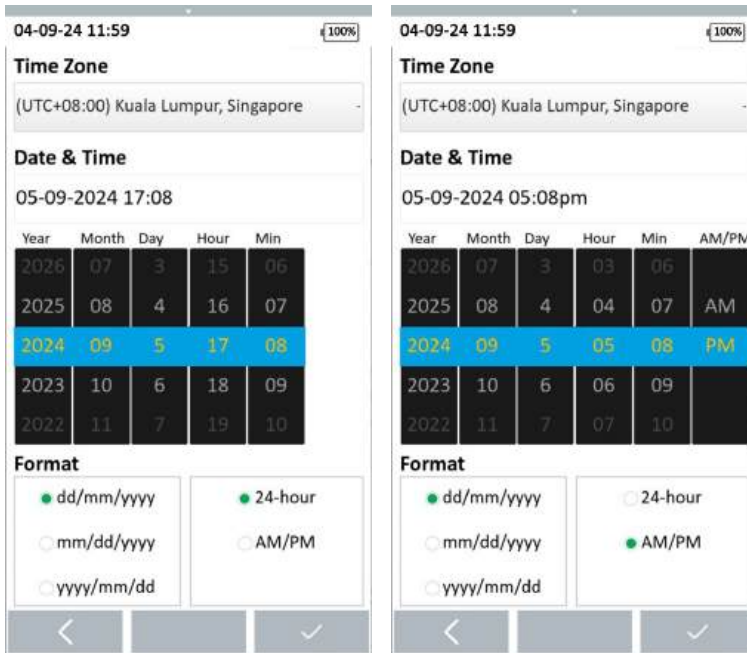

Format > 24-hours

Format > AM/PM

Tap **[Okay]** ✓ to save selections or **[Back]** < to exit from Time & Date Settings.

Power Settings

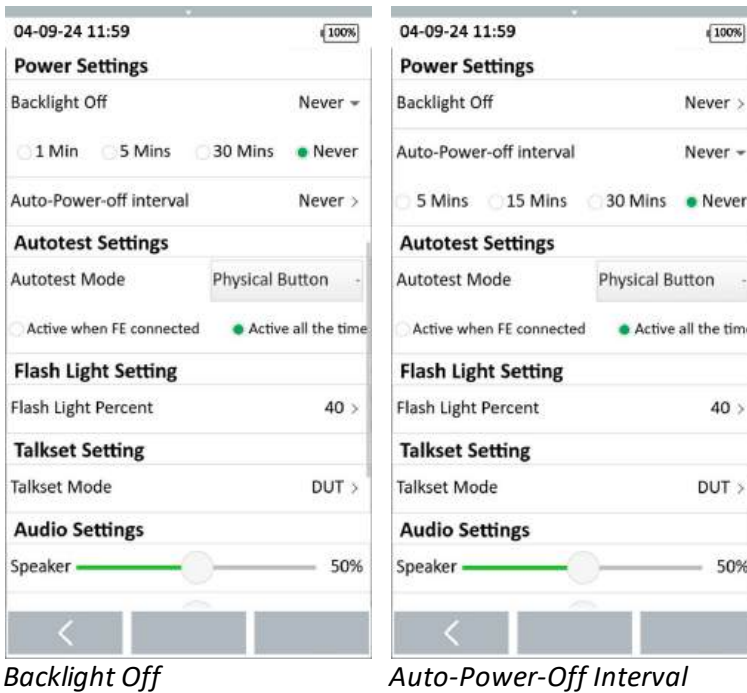

Backlight Off

Select the idle duration before the device backlight switches off to enter power-saving mode. Touch the screen or press the [Home]  button to restore the backlight.

Auto-Power-off Interval

Select the idle duration before the device shuts down.

Auto-test Settings

Auto-test Mode

Select Soft button only or Physical button from the drop-down list to select toggle auto-test using the AUTOTEST or on-screen Auto-test button.

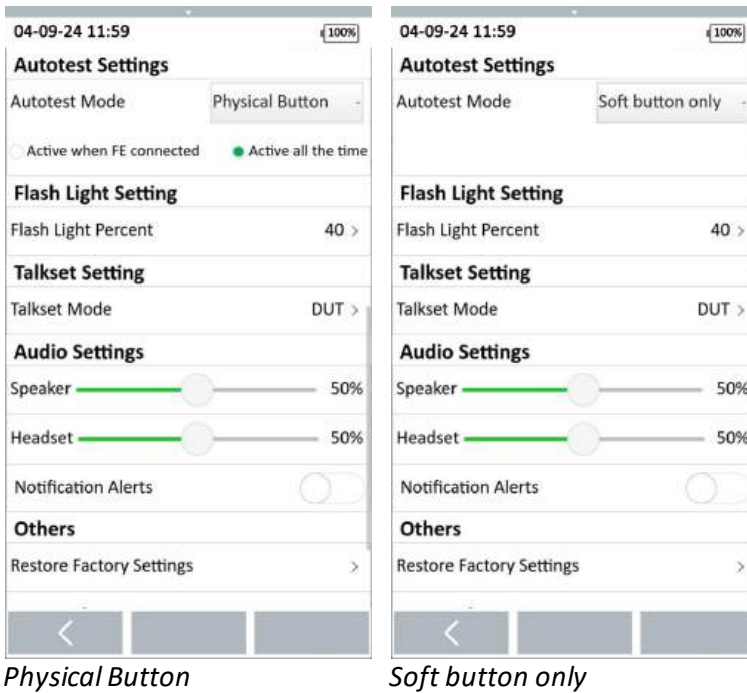

Physical Button

Soft button only

If **[Soft button only]** is selected, the physical AUTOTEST buttons will be disabled and Autotest can only be performed using the soft button on the screen.

If **[Physical button]** is selected, select

- **[Active when FE connected]** to enable Autotest to take place when a far-end connection is detected.
- **[Active all the time]** to enable Autotest to take place when a far-end connection is not detected.

Flash Light Setting

Select brightness intensity of the built-in flash light.



Flash Light Settings

Flash light must be switched off and on again from the slide-down menu for the setting to take effect.

Talkset Setting

Select how the devices will communicate when a talkset is connected.



Talkset Settings

- Select **[DUT]** for the WireXpert MP units to establish a communication connection via a end-to-end link.

- Select **[ETH]** for the WireXpert MP units to establish a communication connection via a Ethernet connection.

To communicate via the **[ETH]** option, connect one end of a patch cable to the patch panel or outlet and the other end to the RJ45 port at the side of LOCAL unit. Repeat same setup at the far-end with the REMOTE unit. The connected outlets or patch panels must be in the same Ethernet network.

Audio Setting

Adjust volume for **[Speaker]** and **[Headset]** by sliding the slider bar.



Audio Settings

Notification Alerts

If enabled, the device will produce notification tones for critical actions.

Others

Restore Factory Settings

Select option to restore all settings to factory defaults.



Others > Restore Factory Settings



CAUTION

Selection of option may cause all or partial of saved data and/or settings in the device to be erased or restored to non-reversible original factory state. Backing up of saved result(s) is recommended before executing option.

Device Info

The Device Info display the system information such as serial numbers, version numbers, calibration dates and etc.

Device Info	Local	Remote
Unit S/N	2400000001	2400000002
Module S/N	2401000001	2401000002
Firmware Ver	1.6.0	1.6.0
Last calibrated	29-JUL-2024	29-JUL-2024
Adapater S/N	3224170022	3224170021
Adapater Type	Cat 6A Channel	Cat 6A Channel
Adapater TestCount	43	48
Batt. Status	Charging	Not Charged
Batt. Level	100	97
Ethernet IP	10.80.224.50	

Others > Device Info

Remote Access

If enabled, device will be able to be controlled by a workstation remotely via VNC. Device and workstation must be connected to the same active network.

To terminate the remote connection, go to **System Settings** → **Remote Access** on the VNC and disable the option.

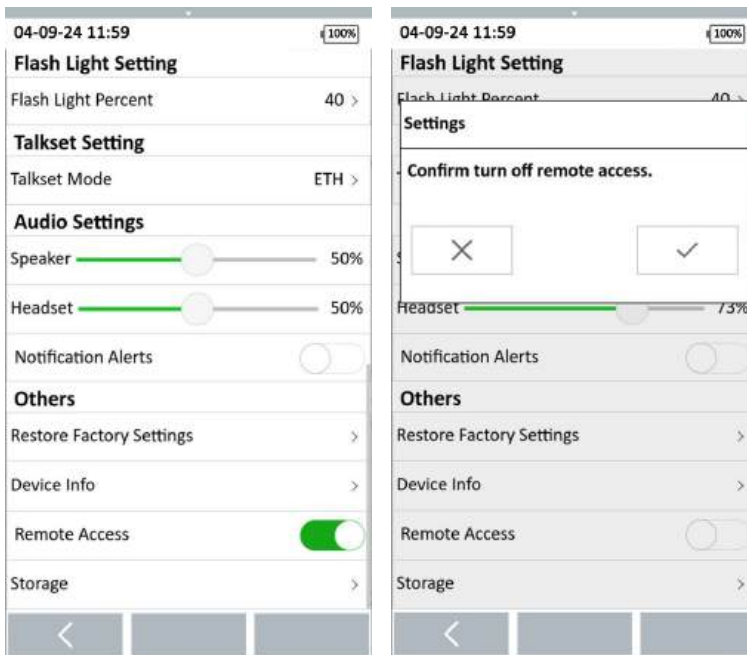

Others > Remote Access

Storage

Select option to view available storage space on the device.



Others > Storage

To view storage of USB device, tap the USB icon Ψ on the status bar and select **[Open]**.

3.3 Copper Connection Status

The Copper Connection Status reports the wiremap status instantaneously upon connection between a LOCAL and REMOTE unit is established.

The Copper Connection Status reports the Copper Connection Status wiremap in three status:

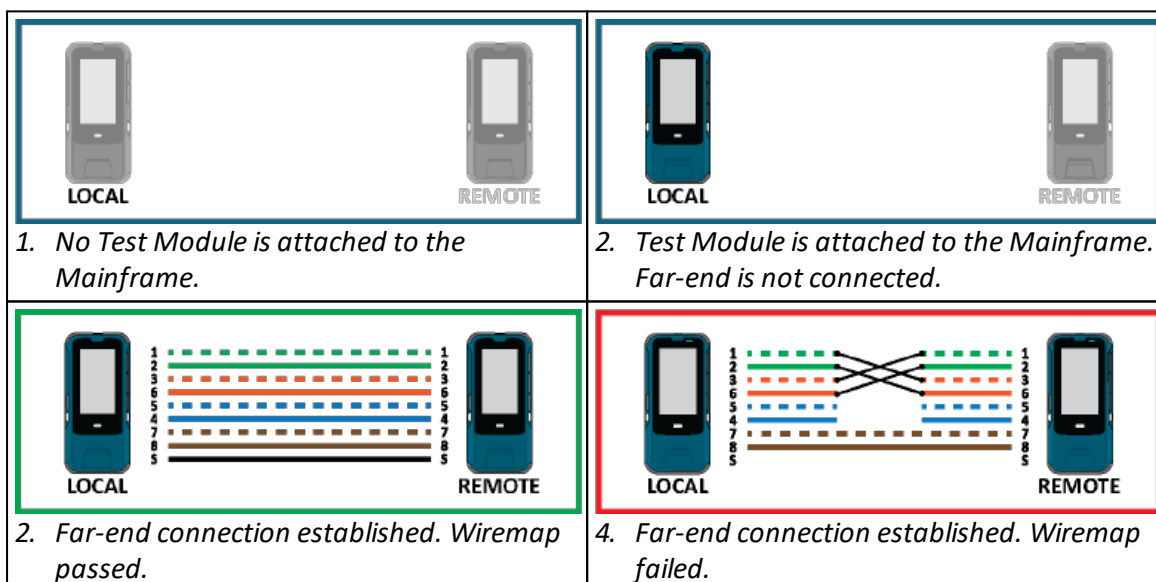

3.4 Project, Site & Data

The **[Project, Site & Data]** consolidates all project oriented configurations and information into one profile. This allows users to quickly locate and manage test sites and results.

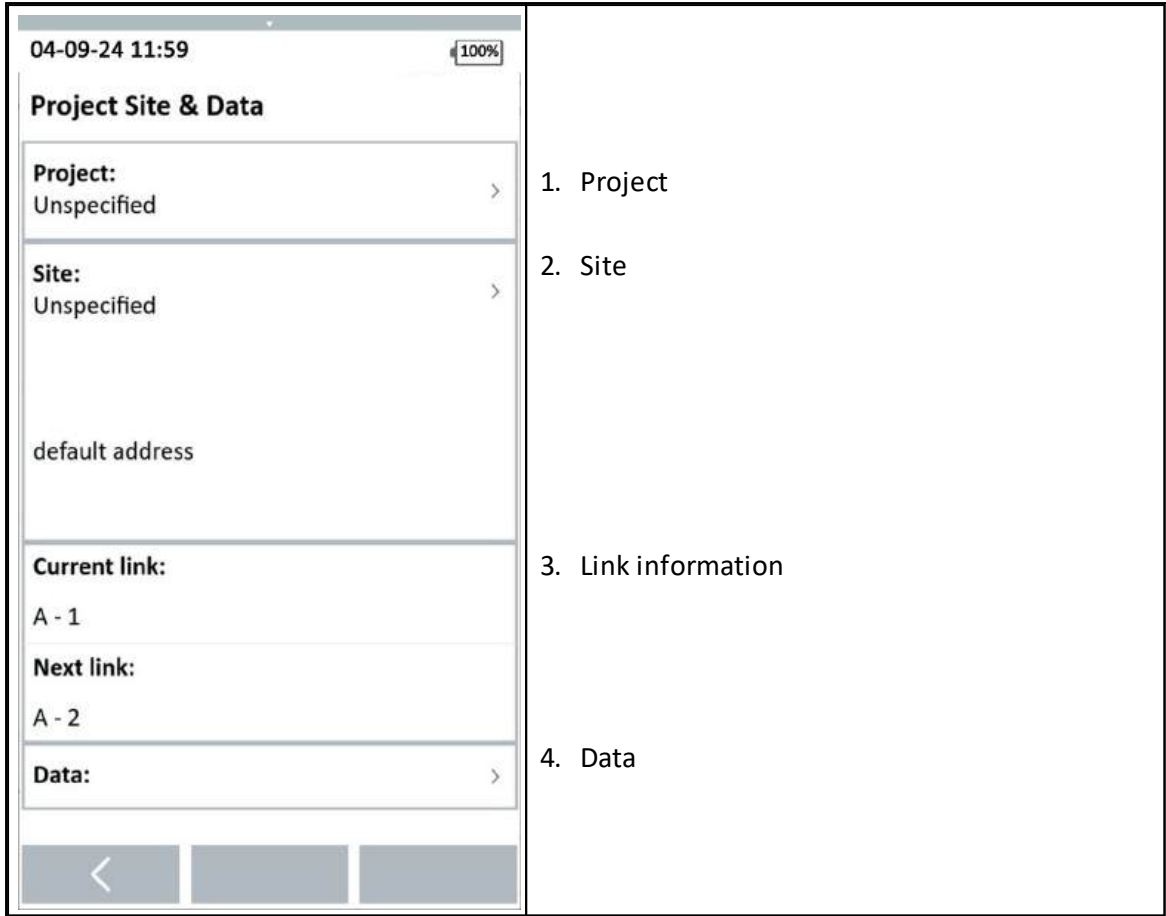

3.4.1 Project

[Project] expands the possibility to manage test results of multiple sites as one consolidated collaboration. Configurations made in the Test Settings can be saved recalled when the Project is loaded. The number in the bracket indicates the total number of created Projects.

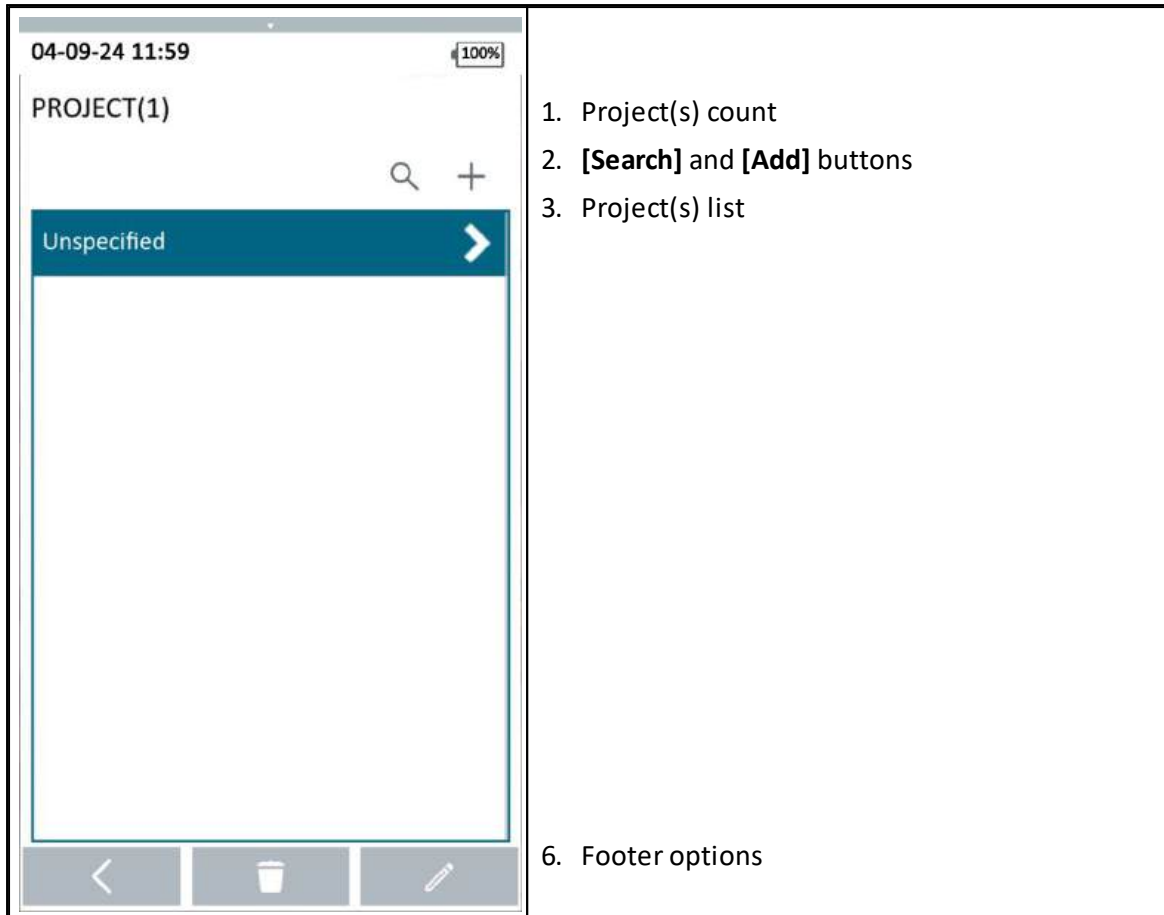

To add a Project, from the **[Home]** screen

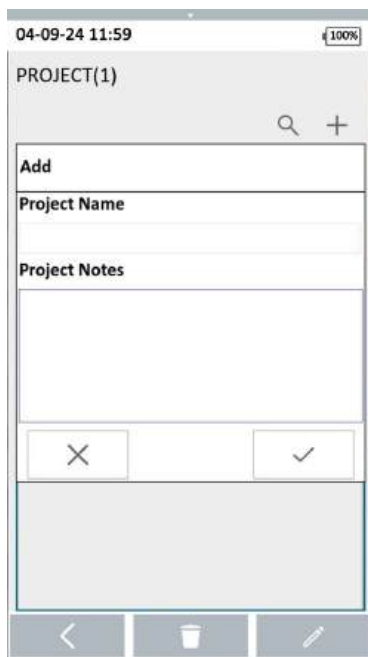

1. Select **Project, Site & Data** → **Project**

2. Tap **[Add]** +.
3. Enter a **Project Name**. Project name is a required field. New sites will be saved in the selected Project.
4. Enter **Project Notes**. Project notes is an optional field, but they provide additional information to the project.
5. Tap **[Okay]** ✓ to confirm, or **[Cancel]** ✕ to exit.

By default, the system creates a “Unspecified” project for default saving if new projects are not created.

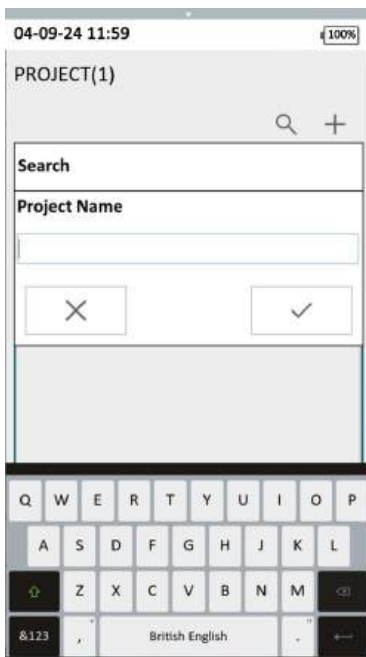

To find a Project,

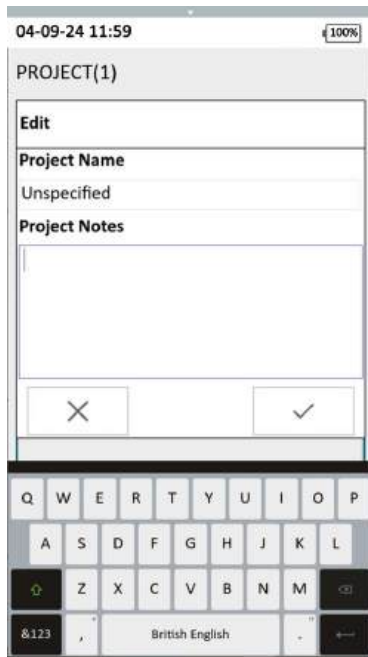

1. Tap **[Search]** 🔍.
2. Enter the characters to search.
3. Tap **[Okay]** ✓ to confirm, or **[Cancel]** ✕ to exit.

To edit a Project,



1. Select project to be edited.
2. Tap **[Edit]** .
3. Tap **Project Notes** to edit.
4. Tap **[Okay]**  to confirm, or **[Cancel]**  to exit.





Note

Project Names can only be edited from the PC software. Refer to User Manual for eXport PC software for more information.

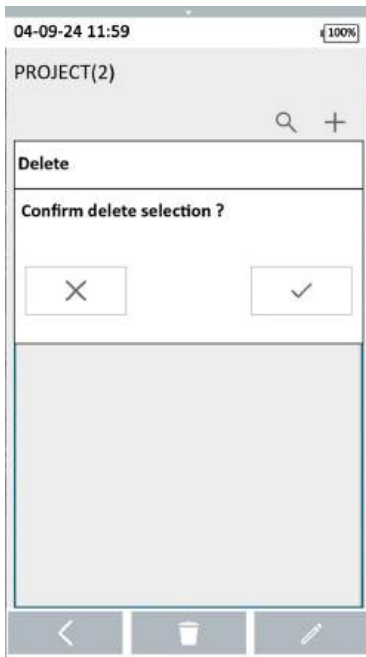
To delete a Project,



1. Select project to be deleted.
2. Tap **[Delete]** .
3. Tap **[Okay]**  to confirm, or **[Cancel]**  to exit.

To delete multiple Projects,

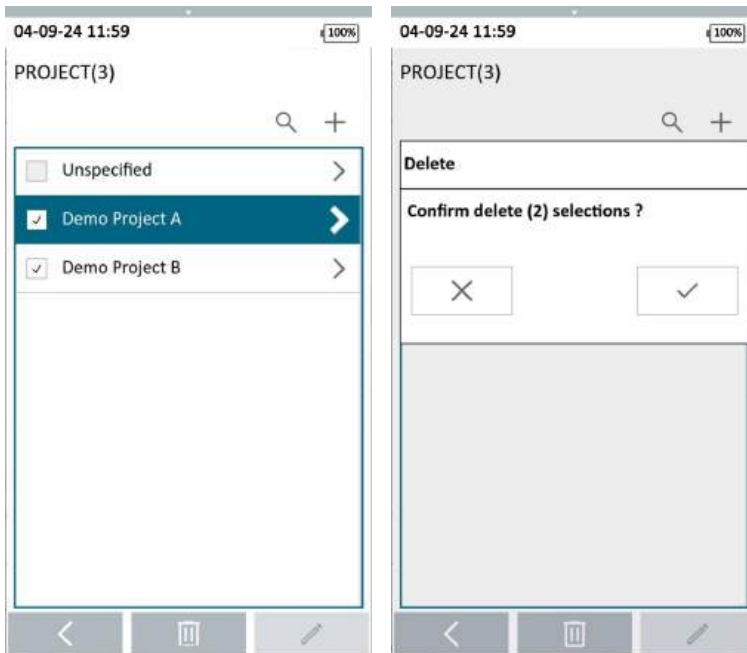

1. Tap and hold on a project to toggle multiple selections.
2. Select projects to be deleted by selecting the check-boxes.

3. Tap **[Delete]** 🗑️.
4. Tap **[Okay]** ✓ to confirm, or **[Cancel]** ✕ to exit.



Note

Site(s) and Data stored in the selected Project will also be deleted.
Deleted Project(s) can be restored from **Tools → Trash**.

3.4.2 Site

[Site] displays information of the selected Project. The number in the bracket indicates the total number of created Sites.

<p>The screenshot shows a mobile application interface. At the top, the date and time are '04-09-24 11:59' and the battery level is '100%'. Below this, the title 'SITE(1)' is displayed. There is a search bar containing the text 'Unspecified' and a right-pointing arrow. To the right of the search bar are a magnifying glass icon and a plus sign. At the bottom of the screen is a footer with three icons: a left arrow, a trash bin, and a pencil.</p>	<ol style="list-style-type: none"> 1. Site(s) count 2. [Search] and [Add] buttons 3. Site(s) list 6. Footer options
--	---

To add a Site, from the **[Home]** screen

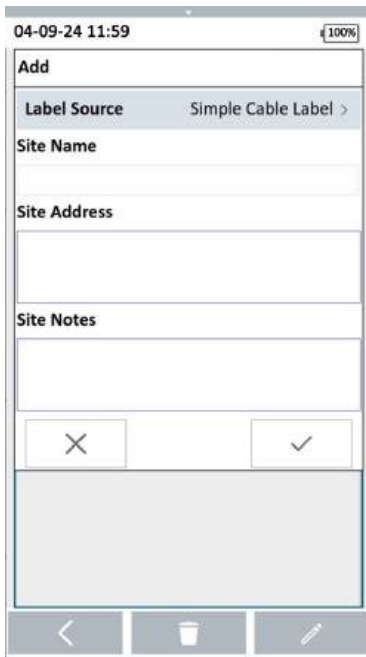



1. Select **Project, Site & Data** → **Site**
2. Tap **[Add]** +.
3. Select **Label Source**. See [Label Source](#) ⁵³ for more information.
4. Enter a **Site Name**. Site name is a required field. Test results will be saved in the selected Site.
5. Enter a **Site Address**. Site name is is optional field, but they provide additional information to the site.
6. Enter **Site Notes**. Site notes is an optional field, but they provide additional information to the project.
7. Tap **[Okay]** ✓ to confirm, or **[Cancel]** ✕ to exit.

By default, the system creates a “Unspecified” site for default saving if new sites are not created.

To find a Site,



1. Tap **[Search]** .
2. Enter the characters to search.
3. Tap **[Okay]**  to confirm, or **[Cancel]**  to exit.

To edit a Site,

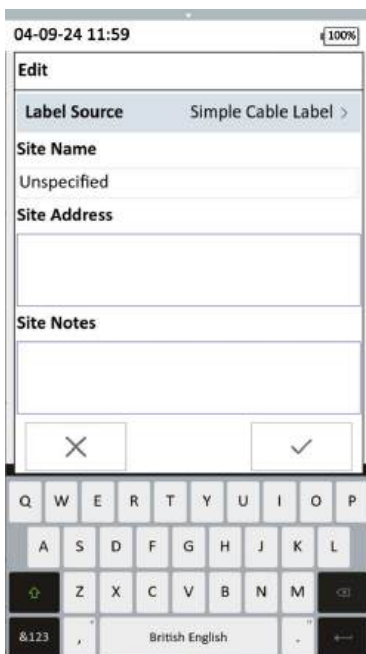

1. Select site to be edited.
2. Tap **[Edit]** .
3. Tap **Site Address** and **Site Notes** to edit.

4. Tap **[Okay]** ✓ to confirm, or **[Cancel]** ✕ to exit.



Note

Site Names can only be edited from the PC software. Refer to User Manual for eXport PC software for more information.



To delete a Site,

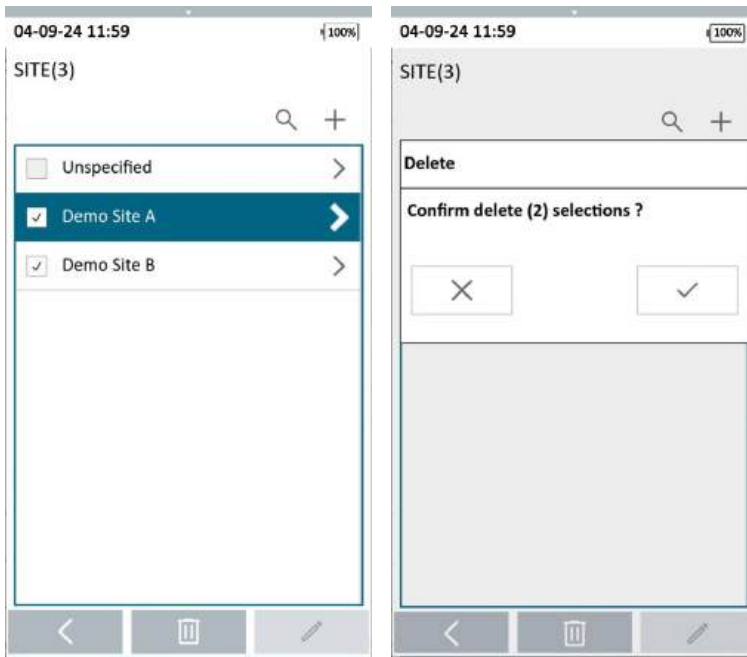

1. Select site to be deleted.
2. Tap **[Delete]** 🗑️.
3. Tap **[Okay]** ✓ to confirm, or **[Cancel]** ✕ to exit.

To delete multiple Sites,



1. Tap and hold on a site to toggle multiple selections.
2. Select sites to be deleted by selecting the check-boxes.
3. Tap **[Delete]** .
4. Tap **[Okay]**  to confirm, or **[Cancel]**  to exit.



Note

Data stored in the selected Site will also be deleted.
 Deleted Site(s) can be restored from **Tools** → **Trash**.

3.4.2.1 Label Source

None

Manual input of label names is required for every saving of result. Autosave will be disabled.

Simple Label

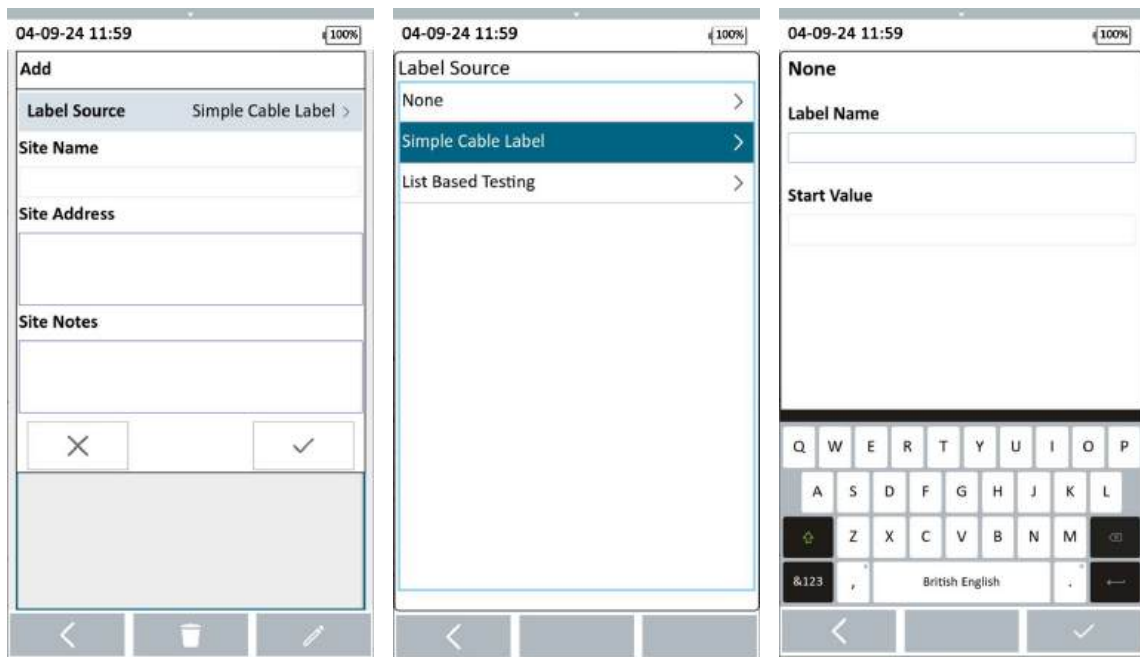

Provides simple numeric increments to a prefix. To configure the simple label scheme:

1. Select Project, Site & Data → Site

1. Select an existing site or **[Add]** + a new site.
2. Select **[Label Source] → Simple Cable Label**.
3. Label Name - Enter desired Prefix (e.g. Office, Company X) for every label.
4. Start Value - Set a numeric start value (e.g. 1, 33, 245) for incremental counts.
5. Tap **[Okay]** ✓ to confirm, or **[Cancel]** ✕ to exit.

List Based Testing

List-based testing enables users to create a label list in the eXport software on a PC and transfer it to WireXpert MP . This feature streamlines the selection process, allowing technicians to quickly identify cables for testing. Optimized for typical testing workflows, it enhances efficiency and significantly boosts productivity.

1. Insert USB flash drive to USB port on WireXpert MP.
2. Device will automatically detect USB flash drive.



1. Select Import **[Label List]**.

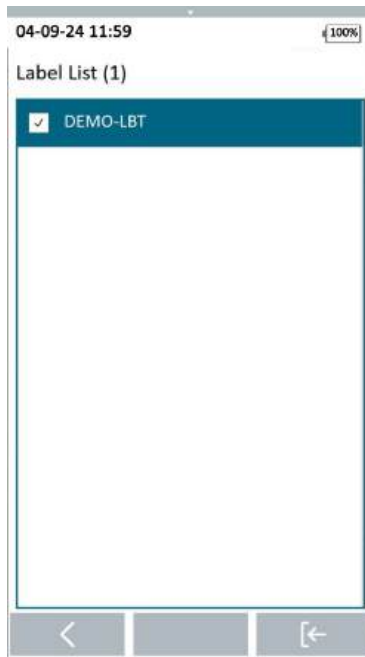

1. Select the custom label list(s) to be copied from the USB flash drive and tap the **[Import]** [←] button to proceed.



1. Tap **[Okay]** ✓ to confirm

1. On the home screen, select **Project, Site & Data** → **Site**



1. Add or select a Site → **Label Source** → **List Based Testing**



1. Select label source file.

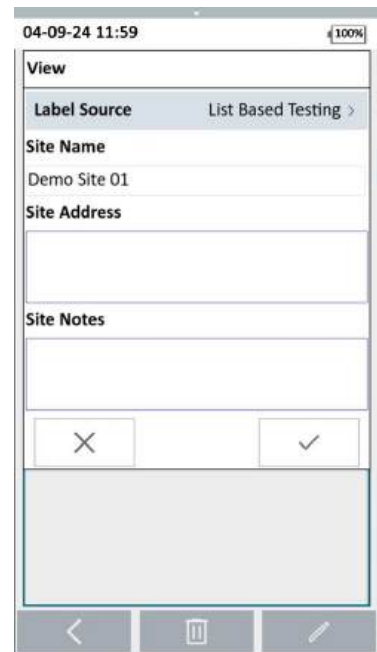

1. Tap the **[Okay]** button to continue.

3.4.3 Link Information

Link Information displays the current and next cable label based on the label source selected.

Current link indicates the cable label of the last saved result.

Next link indicates the cable label if Simple Cable Label label source is selected.

Current and next link will not be indicated if List Based Testing label source is selected.

3.4.4 Data

[Data] provides archive and data management ability to saved test results. Data displays results of the select Site. The number in the bracket indicates the total number of saved results. If list-based testing is selected, the total number of labels generated will be indicated. The total number of passed and failed tests is also indicated.

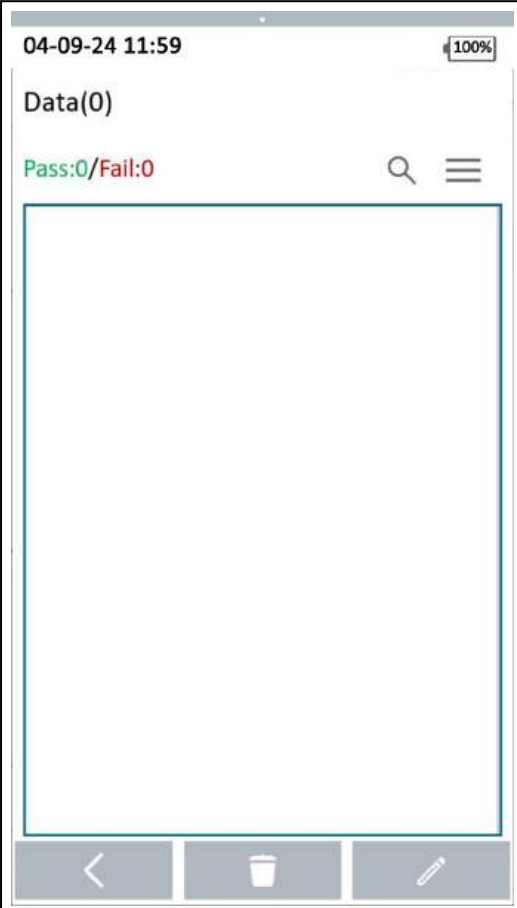

1. Result(s) count
2. Pass/Fail result(s) count, **[Search]** and **[Menu]** buttons
3. Test result(s) list

Understanding the result

<i>Test</i>	<i>Cable Label</i>
<i>status</i>	<i>Cable Type Test date & time</i>

4. Footer options

To sort Data,

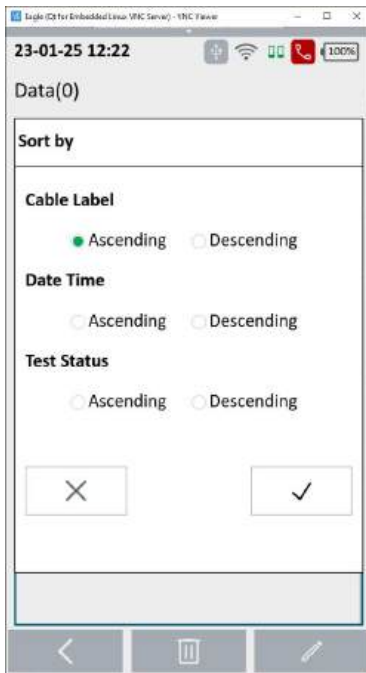

1. Tap [Menu] ☰.
2. Select
 - a. **Sort by Cable Label** to arrange data in ascending or descending alphabetical order.
 - b. **Sort by Date Time** to arrange data in ascending or descending data creation order.
 - c. **Sort by Test Status** to arrange data in ascending or descending test PASS/FAIL order.

To find a saved Data,

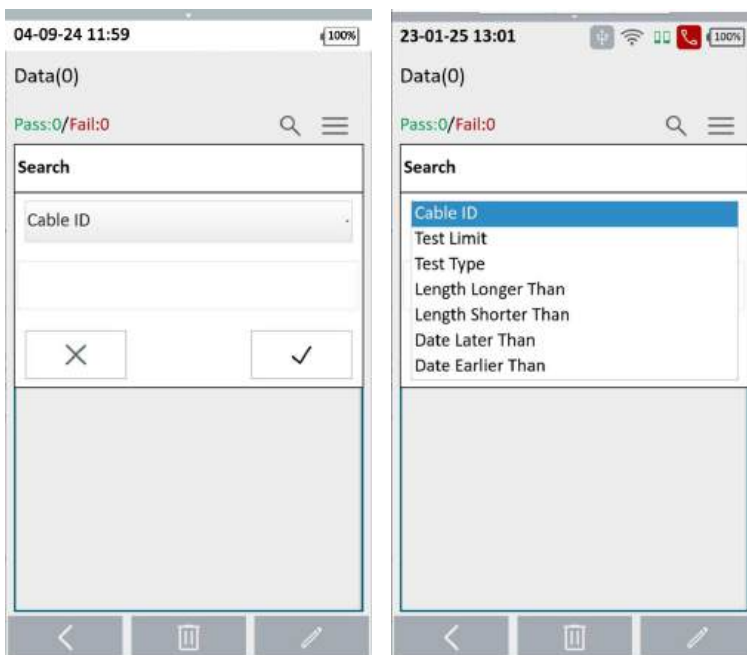



1. Tap [Search] 🔍.

2. Select
 - a. **Cable ID** to search by the saved cable ID.
 - b. **Test Limit** to search by the test limit used for the test, e.g., channel or permanent link.
 - c. **Test Type** to search by the tested media, e.g., copper or fiber.
 - d. **Length longer than** to search by the minimum length.
 - e. **Length shorter than** to search by the maximum length.
 - f. **Data later than** to search by earliest data creation date.
 - g. **Data earlier than** to search by latest data creation date.



To rename a Data file,



1. Select data file to be renamed.
2. Tap **[Edit]** .
3. Tap **Label** to edit.
4. Tap **[Okay]**  to confirm, or **[Cancel]**  to exit.

To delete a Data,



1. Select data to be deleted.
2. Tap **[Delete]** .
3. Tap **[Okay]**  to confirm, or **[Cancel]**  to exit.

To delete multiple Data,



1. Tap and hold on a data to toggle multiple selections.
2. Select data to be deleted by selecting the check-boxes.
3. Tap **[Delete]** .

4. Tap **[Okay]** ✓ to confirm, or **[Cancel]** ✕ to exit.



Note

Deleted Data can be restored from **Tools** → **Trash**.

3.5 Test Settings

[Test Settings] provides results-oriented configurations necessary to perform an AUTOTEST.

Test Limits

Choose from a list of test limits to determine the performance criteria under the selected Standard. Three of the most commonly used limits will be listed in the “Recent Limit” list.

If **[TCL]** option is enabled, the selected electromagnetic severity zone (E1/E2/E3) will be indicated in bracket next to the applicable test limit. Refer **TCL** for more information. Disabled by default.

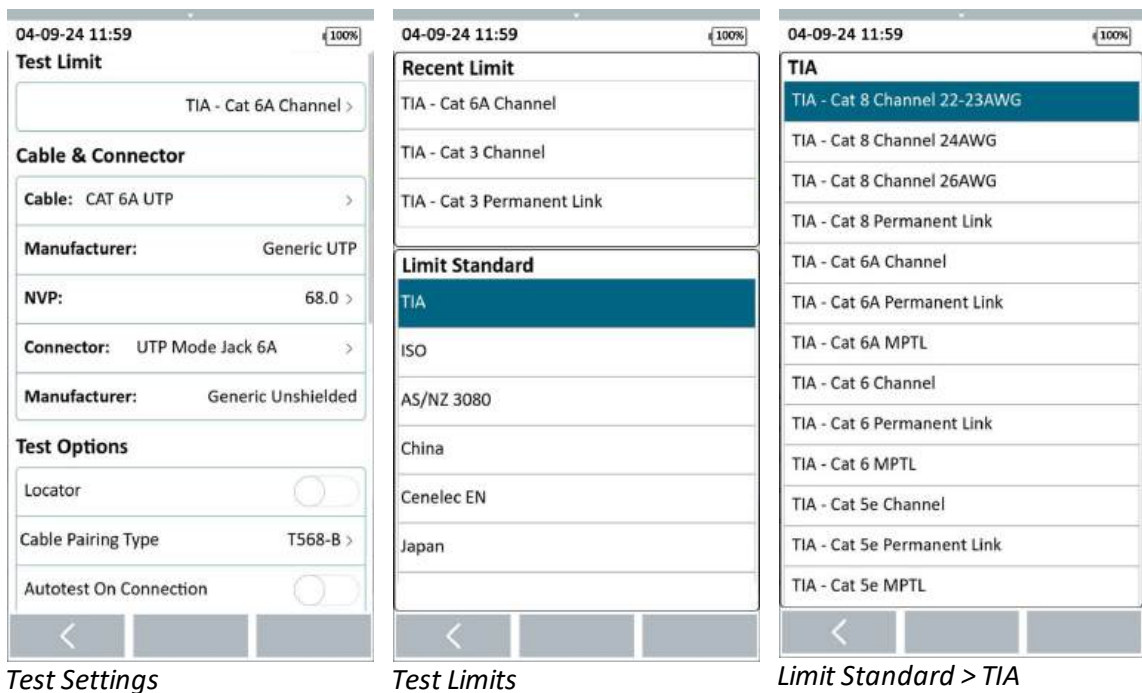

Custom Limit

To import custom limits, create a "Custom Limits" folder in an USB flash drive and copy the custom limit files to the folder.



1. Insert the USB flash drive to WireXpert MP and select **[Custom Limits]**.

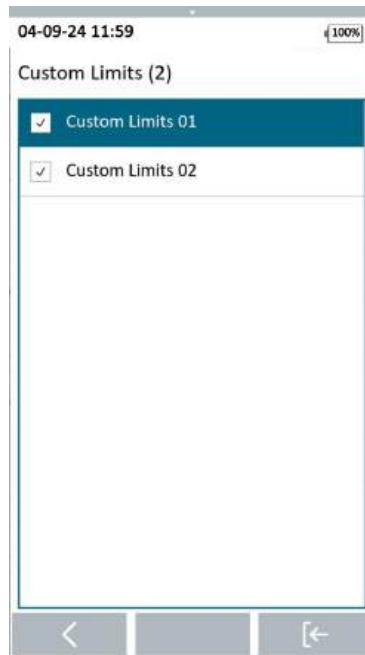

2. Select custom limit files to be imported from the list and tap the **[Import]** button.



3. Tap the **[Okay]** ✓ button to continue.

After importing label, press the **[Home]** button. Select **[Test Settings]** → **Test Limit**.

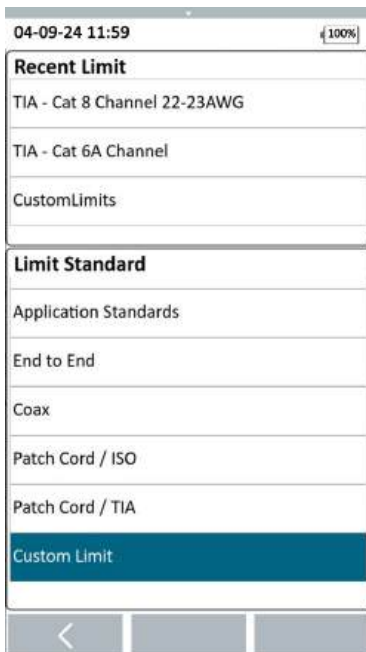

1. Scroll Limit Standard to the end and select **[Custom Limit]**.

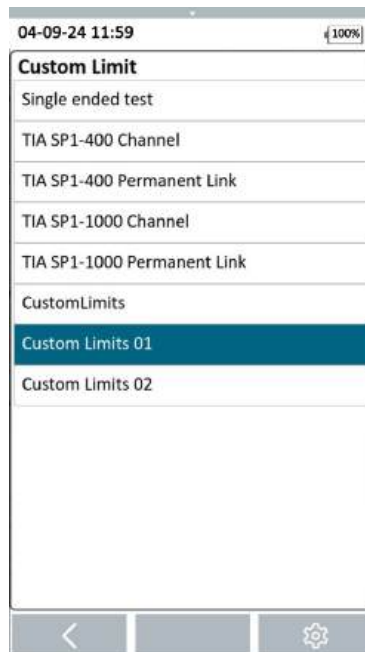

2. Select custom limit files from the list.

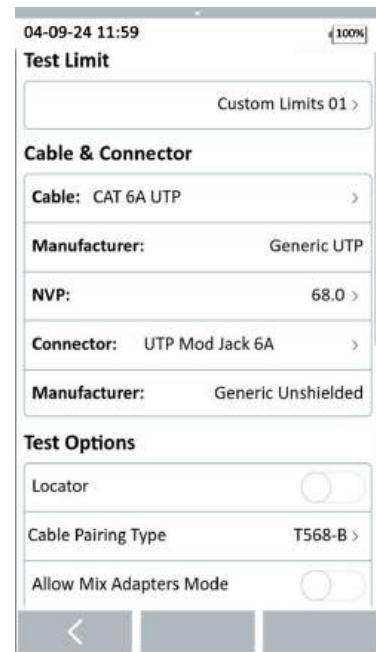

3. Custom limit is now selected.

Cable & Connector

Cable

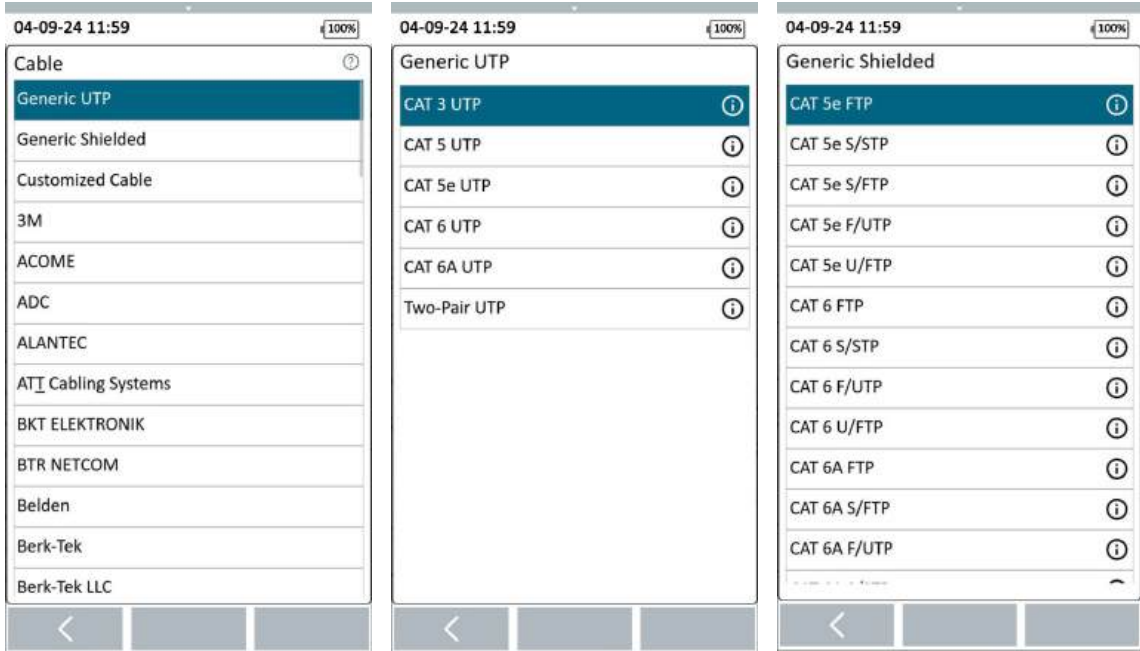

Test Settings > Cable & Connector > Cable

Generic UTP

Generic Shielded

Choose from a list of cable manufacturer for more specific test parameters. If unsure of manufacturer, choose **[Generic UTP]** or **[Generic Shielded]**, or **[Customized Cable]** to create custom cable.

Tap the **[Add]** button to add or **[Edit]** button to delete customized cable(s) from the customized cable list.

When creating customized cable, determining the cable name, number of pairs, construction type, performance grade(S/FTP) and cable's NVP is required.

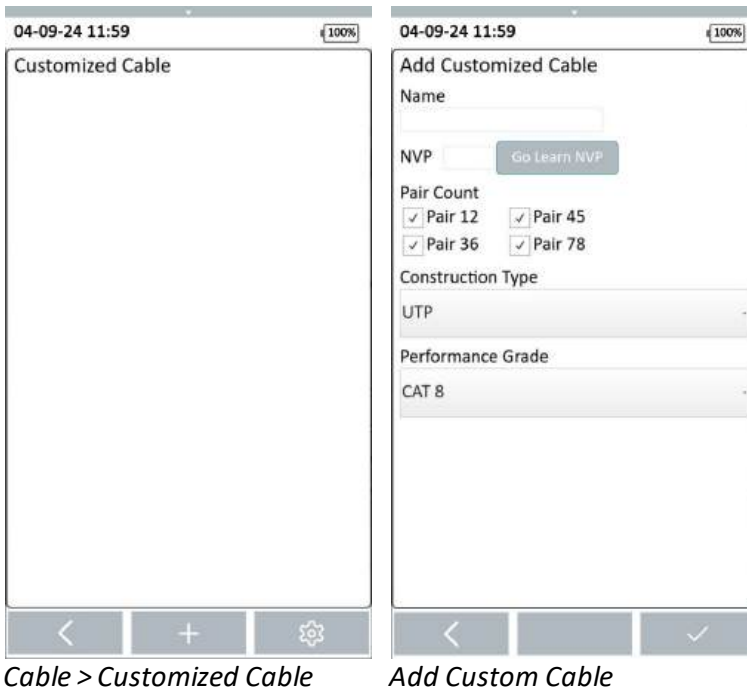

Cable > Customized Cable

Add Custom Cable

NVP

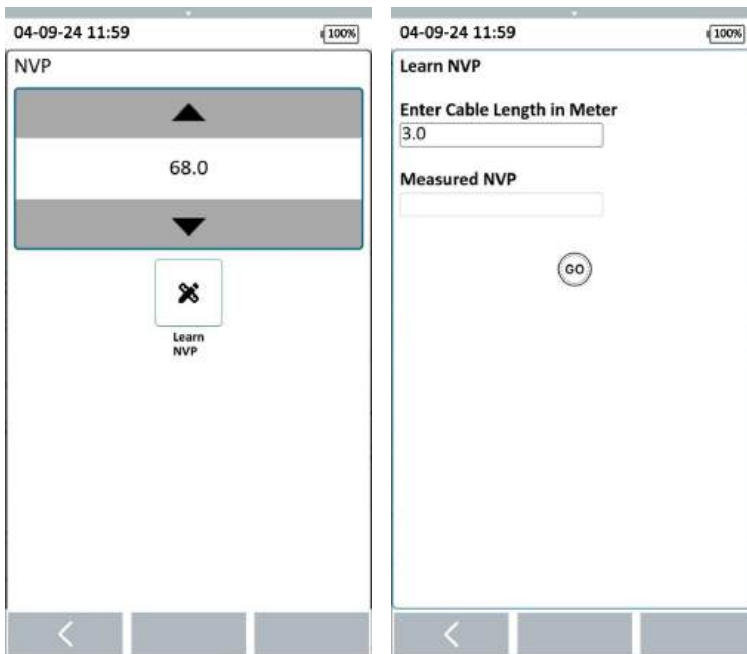

Test Settings > Cable & Connector > NVP

Learn NVP

Determine the Nominal Velocity of Propagation (NVP) value of the cable. The NVP factor is required to determine the accurate length of the cable run to be measured. Based on this constant value, the device performs TDR calculations. Please refer to cable's data sheet for the specific value of the cable type in use.

If the NVP value is unknown, select **[Learn NVP]**. The device will perform NVP measurement based on the cable length input. This option can also be selected from the **[Tools]** menu.

Connector

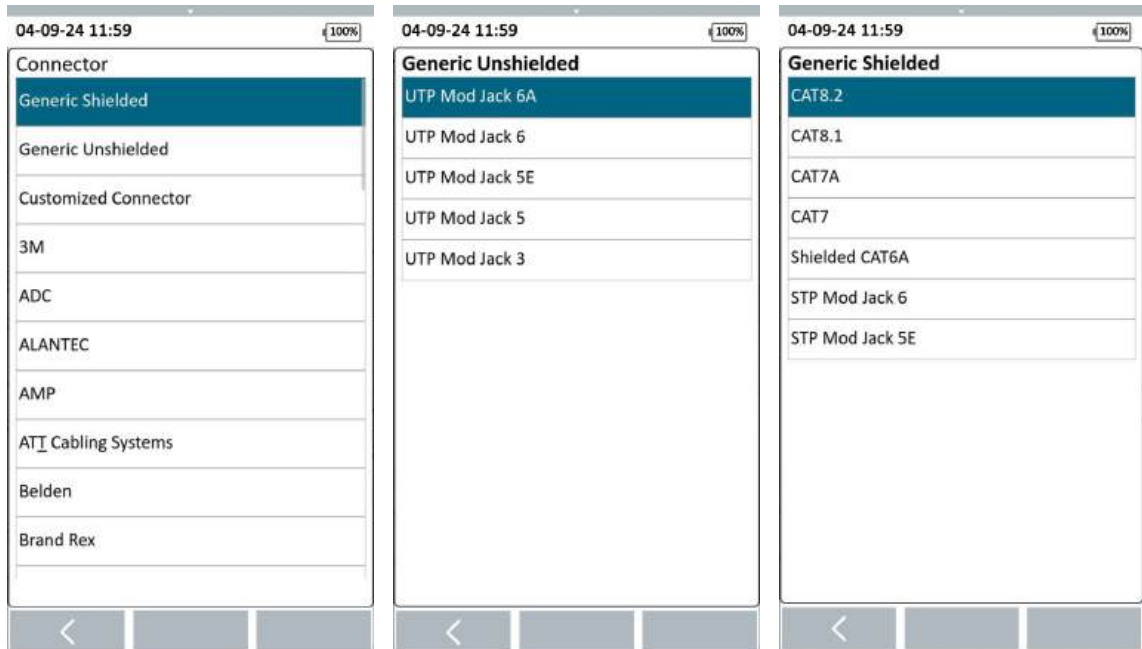

Test Settings > Cable & Connector > Connector

Generic Unshielded

Generic Shielded

Choose from a list of connector manufacturers. If unsure of manufacturer, choose **[Generic Unshielded]** or **[Generic Shielded]**, or **[Customized Connector]** to create custom connector.

Tap the **[Add]** button to add or **[Edit]** button to delete customized cable(s) from the customized connector list.

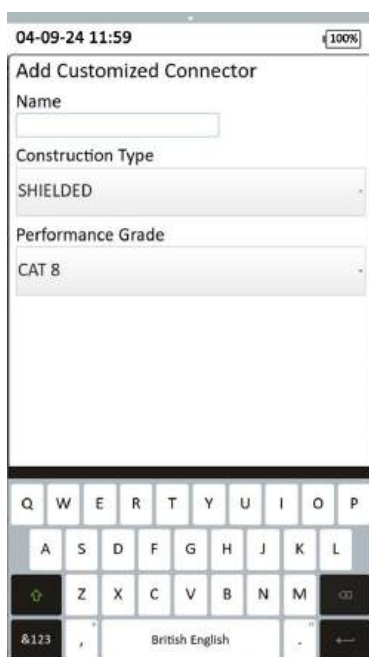

Customized Connector > Add

Test Options

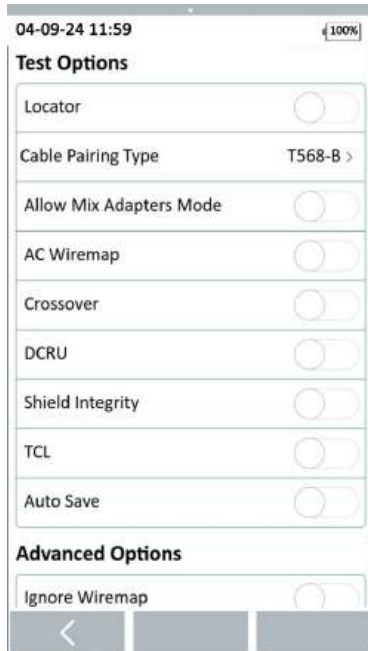

Test Settings > Test Options

Locator

If enabled, the device will display NEXT and Return Loss (RL) fault information in an AUTOTEST result. Disabled by default.

Cable Pairing Type

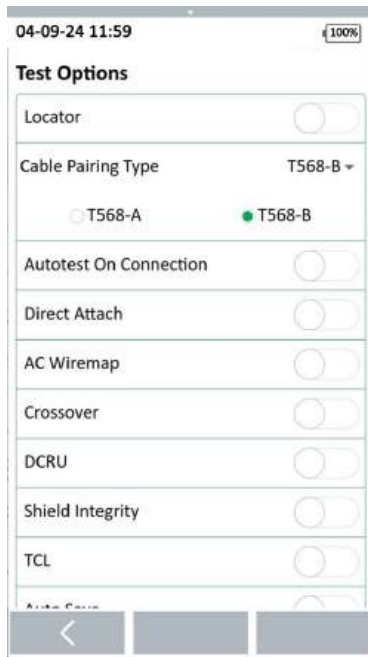

Test Settings > Test Options

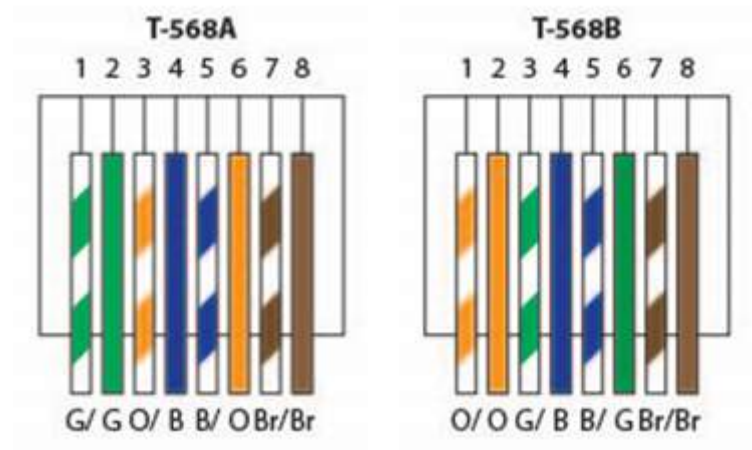

Choose T568A or T568B copper cable wiring standard. “B” is selected by default.

Allow Mix Adapters Mode

If enabled, device will allow test or operations using two different Test Adapters, for example, Permanent Link on LOCAL and Patch Cord on REMOTE for MPTL testing. Refer to [MPTL](#) for more information. Disabled by default.

AC Wiremap

If enabled, device is able to measure test runs with Power over Ethernet (PoE) midspan devices in between. The device supports cable runs with IEEE 802.3 af and 802.3 at injectors. Disabled by default.

Option will be disabled when **[Shield Integrity]** option is enabled.



CAUTION
Do not connect device to a voltage source such as an active telephone jack. Excessive voltage will damage the units and the adapter and void the warranty.

Crossover

If enabled, depending on the test limit selected, device is able to test one or more of the follow crossover cable. Disabled by default.

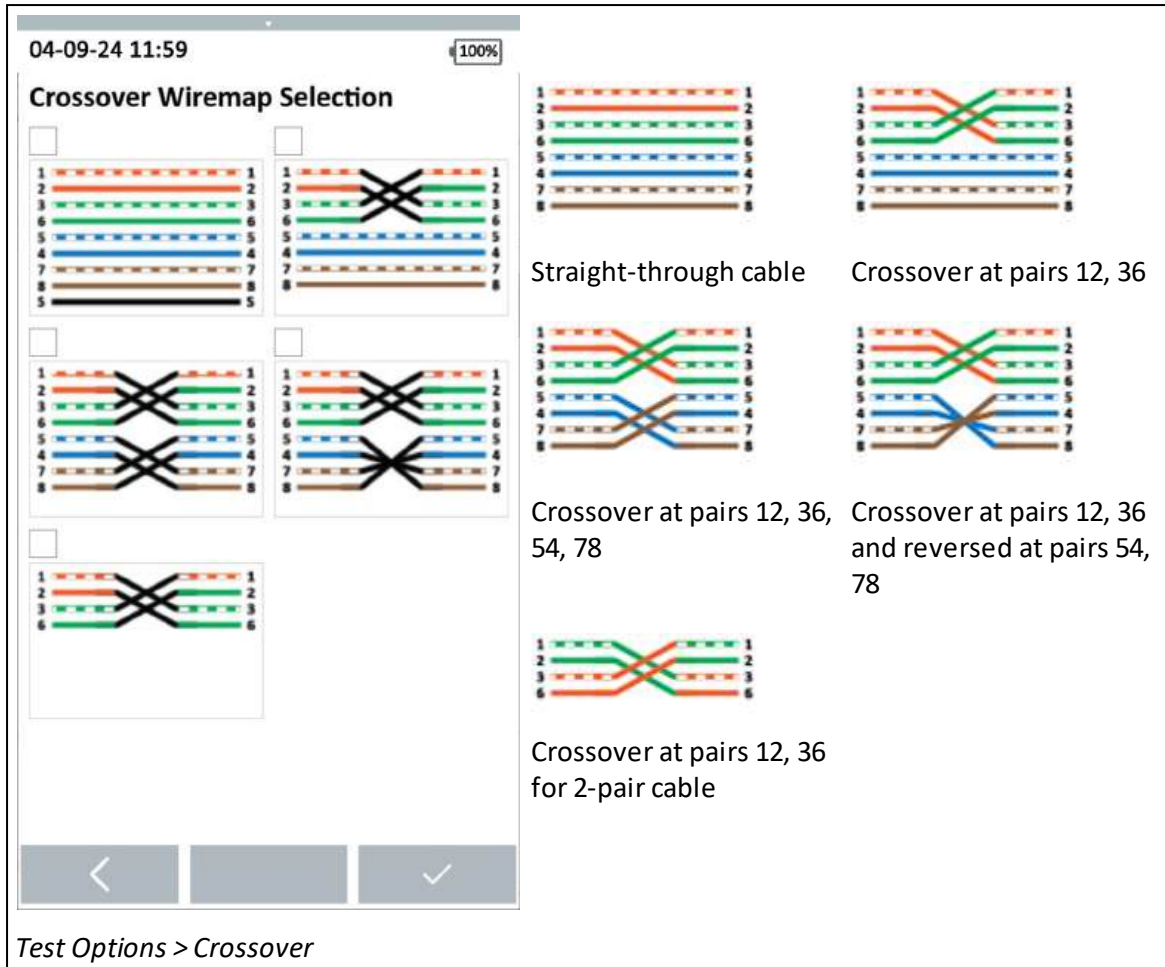

DCRU (Direct Current Resistance Unbalance)

If enabled, device will perform additional DC resistance unbalance test measurements between pairs and within each pair in accordance with TIA and IEC specifications, on top of the AUTOTEST parameters required in a Channel or Permanent Link test. Disabled by default.

Shield Integrity

If enabled, device will perform shield integrity test to identify if a shield is present and connected between both ends on the actual cable under test. Disabled by default.

TCL (Transverse Conversion Loss)

If enabled, device will perform additional TCL test measurements during the Autotest. Depending on the selected limit, electromagnetic exposure zones E1, E2, and E3 as described in ISO/IEC 11801-3 and TIA-1005A can be selected.

The TCL option will be disabled when a non-applicable test limit is selected. Disabled by default.

Zone	Description
E1	low severity (typically commercial office settings)

Zone	Description
E2	medium severity (typically light industrial settings)
E3	high severity (typically high industrial settings)

Auto Save

If enabled, test results will be automatically saved after each Autotest. Only a PASS result will be saved. Option will be disabled if current Label Source is List Based Testing. Refer to **List Based Testing** for more information. Disabled by default.

Advanced Options

Ignore Wiremap

WireXpert MP stops performing an AUTOTEST process when a wiremap FAIL is detected. If enabled, device will continue with the test regardless of the wiremap result. Disabled by default.

Marginal Pass/Fail

If enabled, device will display marginal pass (PASS*) and marginal fail (FAIL*) results. A marginal test result is obtained when its margin is smaller than the accuracy specification for the test parameter. Enabled by default.

Single Ended Test

If enabled, device will be able to perform test using only a LOCAL unit. Depending on requirement, a far-end termination plug may be required. Custom limited must be selected. Disabled by default.



Note

As a single-ended test only takes measurement from the near end, NEXT, Return Loss and length are the only parameters that will be measured.

3.6 Tools

Depending if a Test Module is attached to the Mainframe, the **[Tools]** screen will display different options.

[Tools] is divided into two groups.

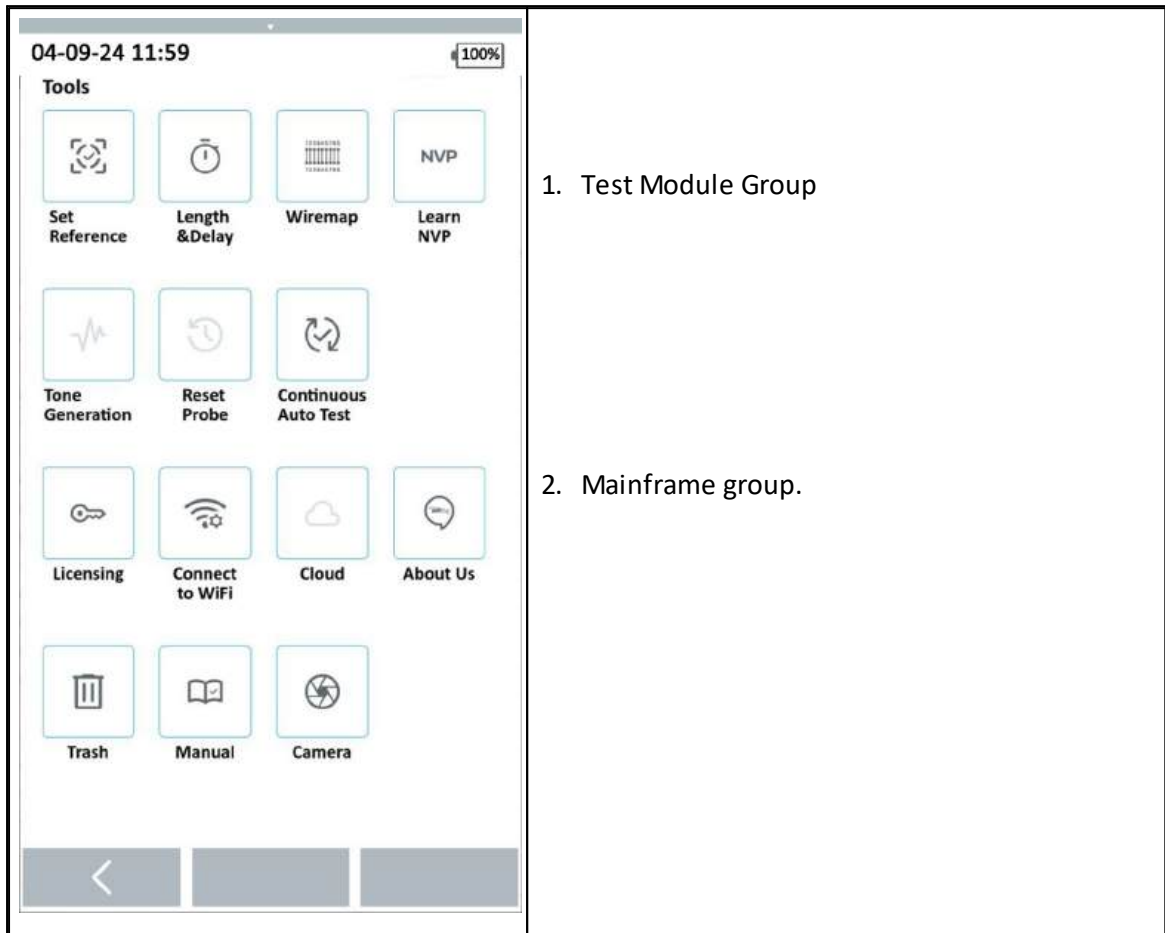

Test Module group

The **Test Module group** provides options and applications that is dependent on the Test Module that is attached to the Mainframe, and the Test Adapter on the Test Module. Depending on the function, some options may only be available on the LOCAL unit.



Set Reference

The device will perform loss compensation through calculation from setting of referencing point. Refer to [Setting Reference](#)⁷⁴ for more information.

Requires: LOCAL and REMOTE



Length & Delay

The device will perform a test to determine the length and propagation delay of each pair using the NVP value programmed by the user.



Tap **[Save]**  to save result.

Requires: LOCAL or REMOTE



Wiremap

The device will perform end-to-end wire mapping test of the cable under test.

Tap **[Retest]**  to test again or **[Save]**  to save result.

Requires: LOCAL and REMOTE

NVP

Learn NVP

The device will perform a test to determine the NVP of the cable using the length value entered by the user.

Minimum length of 30 meters (100 feet) is required.

Requires: LOCAL and REMOTE



Licensing

The device will perform a device upgrade from WireXpert MP 600 to WireXpert MP 3000. Please contact your local vendor for more information.

Requires: LOCAL and REMOTE

Requires: Upgrade License Key. Refer to <https://itnetworks.softing.com> for more information.



Continuous Autotest

The device will perform Autotest automatically based on a preset interval.

Requires: LOCAL and REMOTE

Mainframe group

The **Mainframe group** provides options that is independent from any test modules. Optional add-ons may be required to access these options. They do not affect the general operation of the device.



Wi-Fi

If enabled from the [slide-down menu](#)²⁵, the device will scan for Wi-Fi access points (AP) and attempt connect to the selected AP.

Requires: LOCAL only

Requires: USB Wi-Fi dongle (230063)



About Us

Contact information of Softing offices worldwide.





Manual

Opens the User Manual.



Trash

The Trash bin stores deleted user created data, i.e., projects, sites, data, custom cables and connectors.

Select data and tap **[Delete]**  to permanently delete the data or **[Restore]**  to restore data to its original location.



CAUTION

Selected data will be permanently erased and cannot be recovered.



Camera

Opens the Camera application.

3.6.1 Camera

The WireXpert MP series has a built-in camera module at the top of the Mainframe to enhance the cable certification process.

Before performing an Autotest:

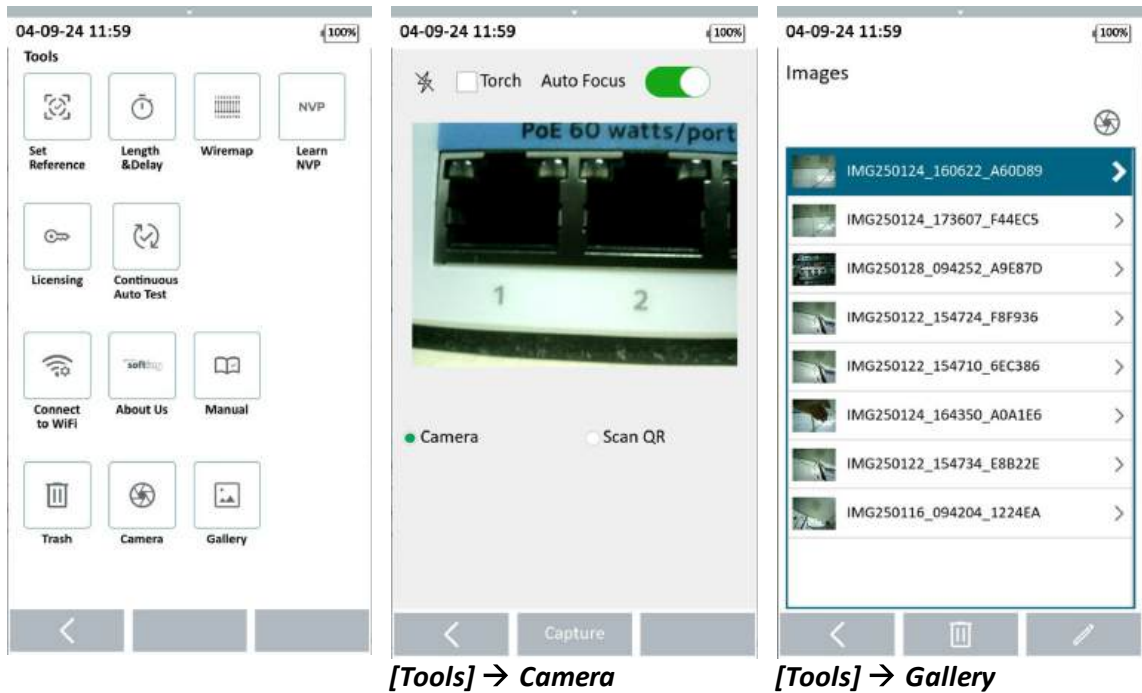

1. Launch the camera app from the [Tools] menu at the home screen by selecting [More] . . . → [Camera] 📷.
2. In the Camera app, select the [Camera] option.
3. Aim and capture the image and tap the [Capture] button.
4. To view the image, select [Gallery] 🖼️ from the [Tools] menu.

After performing an Autotest:

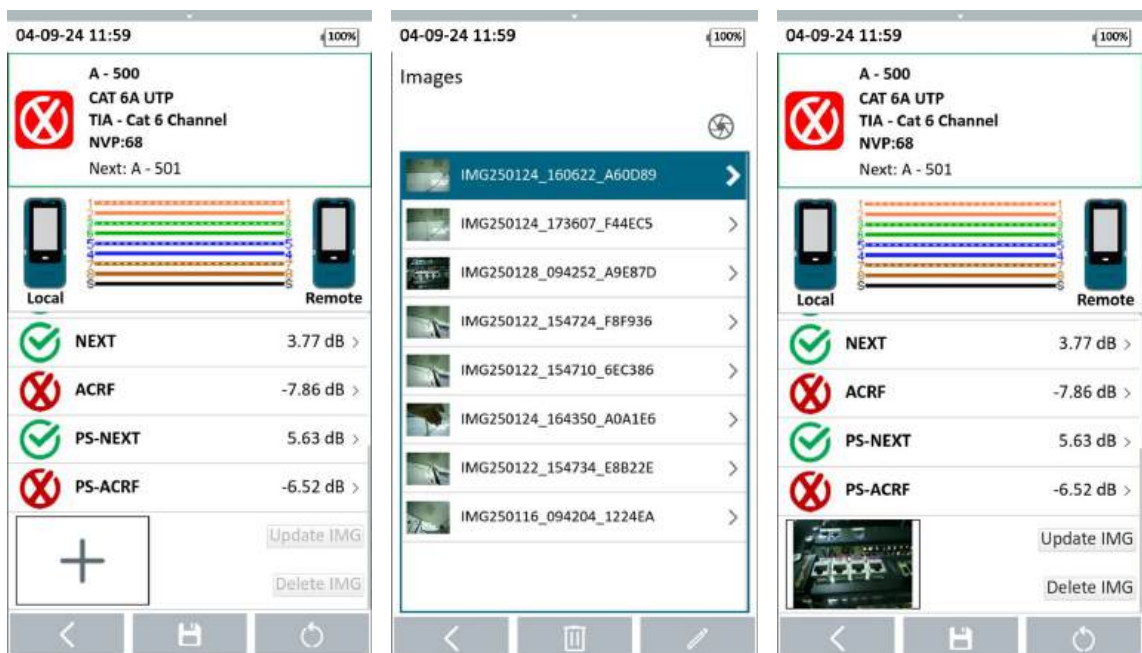

1. Scroll to the bottom of the test result and select **[Add]** +.
2. Select image from list or tap **[Camera]** 📷 to capture image.
3. Ensure **[Camera]** is selected and tap the **[Capture]** button.
4. To edit file name of the image, select image and tap the **[Edit]** ✎ button.
5. To delete image, select image and tap the **[Delete]** 🗑 button.
6. To delete multiple images, tap and hold on an image file.
7. Select image(s) and tap the **[Delete]** button to delete the selected file(s).
8. Select image and tap the **[Back]** < button to return to the test results.
9. To replace image, tap the **[Update IMG]** button.
10. Tap the **[Save]** 💾 button to save result.



Note

Image cannot be added to a test result after exiting the test result screen.





Note

The feature will only support if the QR code contains text characters. Only the first 72 characters including delimiters will be saved as the cable label.

4 Using the Product

Configuration the device for an AUTOTEST

After configuring the system settings, follow these steps to set up an AUTOTEST.

1. Swipe downwards from the top of the screen to bring down the slide-down menu.
 - a. Under User Portal, login using the designated credentials.
2. From the Home screen, select [\[Project, Site & Data\]](#) ⁴³
3. Select [\[Project\]](#) ⁴⁴
 - a. Select or create a new [Project](#) ⁴⁴
 - b. Tap **[Back]** < to return to the previous screen
4. Select [\[Site\]](#) ⁴⁹
 - a. Select or create a new [Site](#) ⁴⁹
 - b. Select [\[Label Source\]](#) ⁵³
5. Press the [\[Home\]](#) ²⁴  button to return to the Home screen
6. Select [\[Test Settings\]](#) ⁶⁰
 - a. Select **[Test Limits]**
 - b. Select **[Cable]**
 - c. Select **[Connector]**
7. Press the [\[Home\]](#) ²⁴  button and select [\[Set Reference\]](#) ⁷⁴.

4.1 Setting Reference

It is necessary to perform a set reference measurement if the LOCAL and REMOTE units are being paired for the first time. If there is a mismatch in firmware versions or a set reference has not been performed, AUTOTEST will be denied, until these conditions are corrected. Please also ensure that the calibration dates of the devices have not expired.

Set reference procedures are the same with CAT 6A and CAT 8.



1. LOCAL & REMOTE Mainframe units
2. 2x Copper Test Modules (230052 or 230053)
3. 2 x Permanent Link Test Adapters (230055 or 230072)
4. 2 x Channel Test Adapters (230054 or 230071)
5. 1 x Permanent Link Test/Reference Cord (230069)
6. 1 x DCRU Calibration Artifact (230070)

To set reference,

1. Ensure that the Copper Test Modules are properly attached to the Mainframes of the LOCAL and REMOTE units.
2. Connect a Permanent Link adapter to the LOCAL unit.
3. Connect a Channel adapter to the REMOTE unit.
4. Connect the 2 units together using the reference cord provided in the kit.
5. From the Home screen, select **[Tools] → Set Reference**
6. Ensure that the 2 units are connected . Tap **[Next]** to continue.
7. Enable **[DCRU Calibration]** to perform the additional step of performing calibration of the DCRU measurements. This step is optional and will not affect the accuracy of the Set Reference if disabled. If enabled,

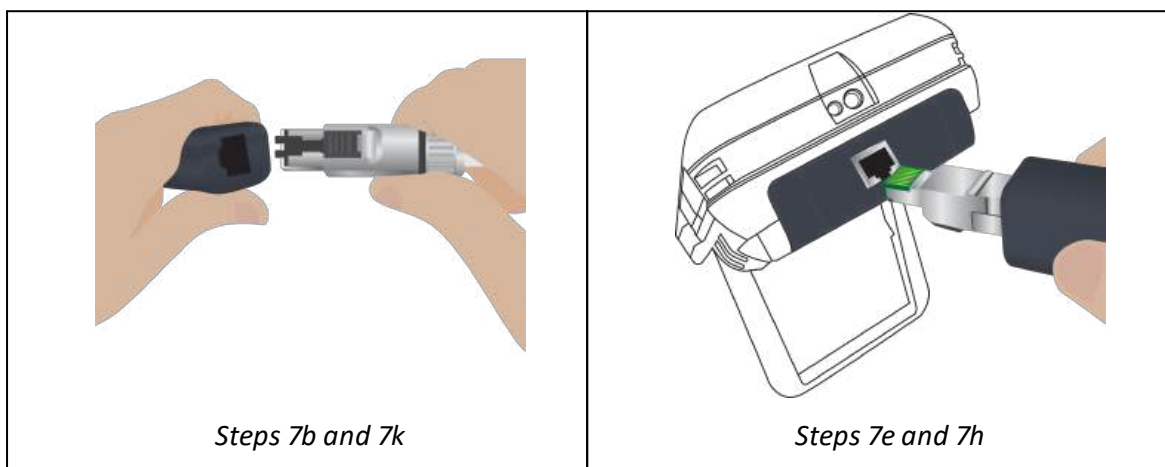

- a. Respective instructions will be prompted on the LOCAL and REMOTE units after Set Reference is completed.

On the LOCAL unit,

- b. Disconnect the reference cable from the REMOTE unit and connect it to the DCRU Calibration Artifact.
- c. Tap **[Next]** to continue.
- d. Swap the Permanent Link Test Adapter with the other Channel Test Adapter.
- e. Disconnect the DCRU Calibration Artifact from the cable and connect it to the Test Adapter.
- f. Tap **[Next]** to continue.
- g. Disconnect the DCRU Calibration Artifact.

On the REMOTE unit,

- h. Connect the DCRU Calibration Artifact to the Channel Test Adapter.
- i. Tap **[Next]** to continue.
- j. Swap the Channel Test Adapter with the other Permanent Link Test Adapter.
- k. Connect the TERA end of the reference cord to the Test Adapter and the other end to the DCRU Calibration Artifact.

- l. Tap **[Next]** to continue.
- m. Set Reference and DCRU calibration is now completed.

Set Reference will fail in the event of-

- o Test adapters mismatch, i.e., two channel or permanent link adapters, one CAT 6A and one CAT 8.
- o Firmware version mismatch between LOCAL and REMOTE units.
- o No connection between LOCAL and REMOTE units.



Note

Diagrams and images used are for illustration purposes only and do not represent suggested test values. Reference and test values vary to usage and condition.



Note

DCRU Calibration is an optional but recommended step to ensure accuracy during the measurement of DCRU parameters. It may be disabled if DCRU measurements are not required.

4.2 Performing an Autotest (WIP camera function)



CAUTION

Do not connect device to a voltage source such as an active telephone jack. Excessive voltage will damage the units and the adapter and void the warranty.

Testing Guide for Permanent Link Testing

Please ensure you have the following test equipment before conducting the test.



1. LOCAL & REMOTE Mainframe units (230051)
2. 2x Copper Test Module (230052 or 230053)
3. 2 x Permanent Link Test Adapter (230055 or 230072)
4. 2 x Permanent Link/Test Reference Cord (230069)

Permanent Link (PL) test is comprised of the connection from a patch panel to a telecommunication outlet (horizontal cabling) using Permanent Link test adapters at each end of the link under test. See [Permanent Link](#)¹⁹ for more information.

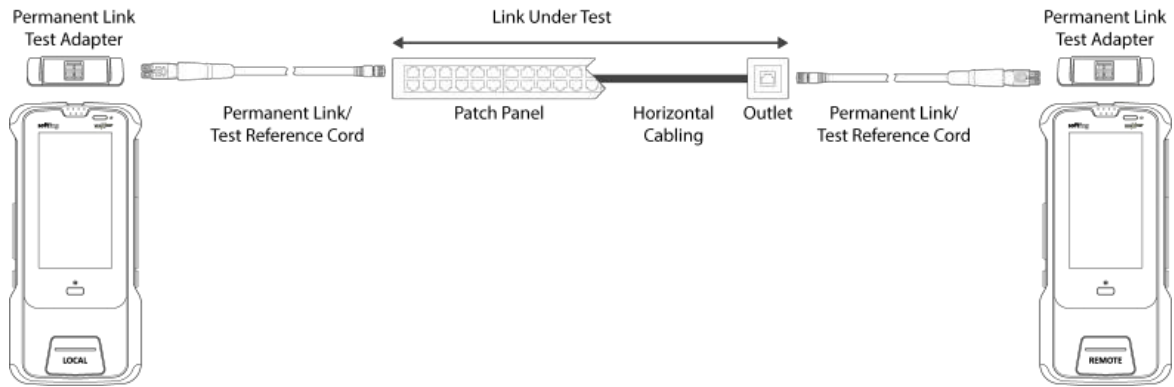

1. Attach the Permanent Link Test Adapters into the LOCAL and REMOTE units of the device.
2. Power ON the devices.
3. Check that devices are in Copper testing mode.
4. Set reference is required if the devices are being paired for the first time or has not been used for an extended period.
5. From the **[Home]** screen, select **[Test Settings]** → **[Test Limits]**
6. Choose the **Limit Standard** and select the **Permanent Link** limits.
7. Configure other settings if necessary.
8. Connect the one end of the unit to the patch panel and the other unit to the outlet using the Permanent Link/Reference cords provided.
9. Press the AUTOTEST button to begin AUTOTEST.

Testing Guide for Channel Link Testing

Please ensure you have the following test equipment before conducting the test.



1. LOCAL & REMOTE Mainframe units (230051)
2. 2x Copper Test Module (230052 or 230053)
3. 2 x Channel Test Adapter (230054 or 230071)
4. Patch-cords to equipment (Not provided)

Channel (CH) test is comprised of the connection from an active device (eg. Router) in a data rack, a telecommunication outlet (horizontal cabling) and the connecting patch cords at both ends using Channel test adapters at each end of the link under test. The recommended length for the patch cord from the patch panel and the outlet is 5m. See [Channel Link](#)¹⁹ for more information.

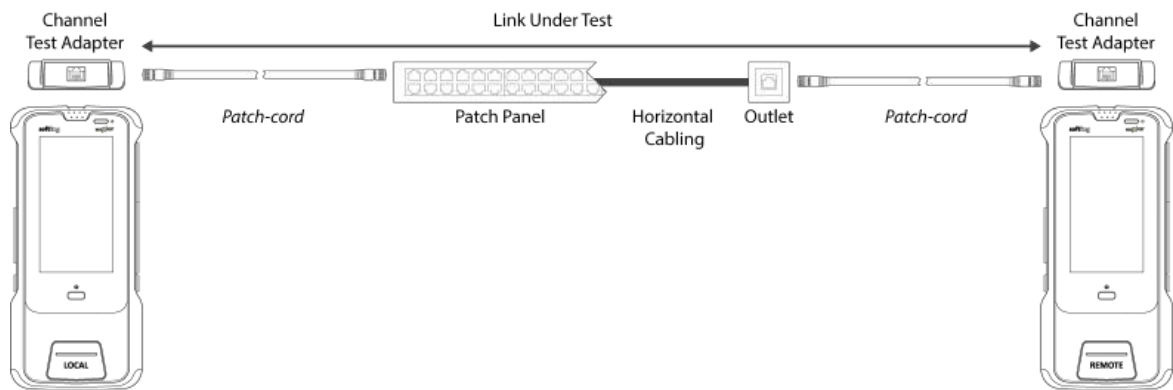

1. Attach the Channel Test Adapters into the LOCAL and REMOTE units of the device.
2. Power ON the devices.
3. Check that devices are in Copper testing mode.
4. Set reference is required if the devices are being paired for the first time or has not been used for an extended period.
5. From the **[Home]** screen, select **[Test Settings]** → **[Test Limits]**
6. Choose the **Limit Standard** and select the **Channel** limits.
7. Configure other settings if necessary.
8. Connect the one end of the unit to the patch panel and the other unit to the outlet using the patch-cords that will be used to connect the active devices.
9. Press the AUTOTEST button to begin AUTOTEST.

Scanning a QR code as a Cable ID

If a QR code or barcode containing the cable ID is available, it can be used to replace the existing label. To use a QR code or barcode as the cable ID,

1. After an Autotest, select **[Save]** on the result screen.
2. Tap **[Scan]** and point the camera to the QR code or barcode.
3. Ensure that **[Scan QR]** is selected and tap the **[Capture]** button.
4. Select **[Okay]** after the cable ID has been captured or tap **[Scan]** to scan again.
5. Test result is now saved .



Note

1. **Test Settings** → **Test Options** → **Auto Save** must be disabled to use this feature.
2. **Project, Site & Data** → **Site** → **Label Source** → **None** must be selected to use this feature.

Adding an image to the test result

An image can be added to the test result as an attachment. The attached image will also be displayed when exported as a PDF report. To add an image to the test result,

1. Scroll to the bottom of the test result and select **[Add]** +.
2. Select image from list or tap **[Camera]** 📷 to capture image.
3. Ensure **[Camera]** is selected and tap the **[Capture]** button.
4. To edit file name of the image, select image and tap the **[Edit]** ✎ button.
5. To delete image, select image and tap the **[Delete]** 🗑 button.
6. To delete multiple images, tap and hold on an image file.
7. Select image(s) and tap the **[Delete]** button to delete the selected file(s).
8. Select image and tap the **[Back]** < button to return to the test results.
9. To replace image, tap the **[Update IMG]** button.
10. Tap the **[Save]** 💾 button to save result.



Note

Captured images can only be deleted before the test result is saved.

4.3 Understanding the Results

Press the **AUTOTEST** button once settings and limits have been selected. WireXpert MP will use the last configuration or factory settings to perform the Autotest if new settings are not configured.

The device will display summarized result with PASS or FAIL once an Autotest is completed. Tap the **[Save]** 💾 button to save the results or the **[Retest]** 🔄 button to perform an Autotest again.

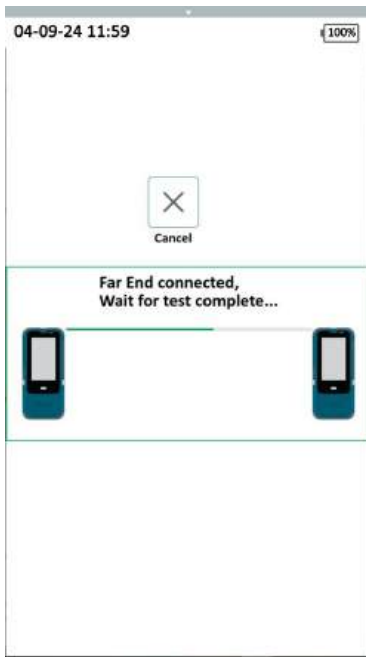

Autotest in progress



Autotest is completed¹

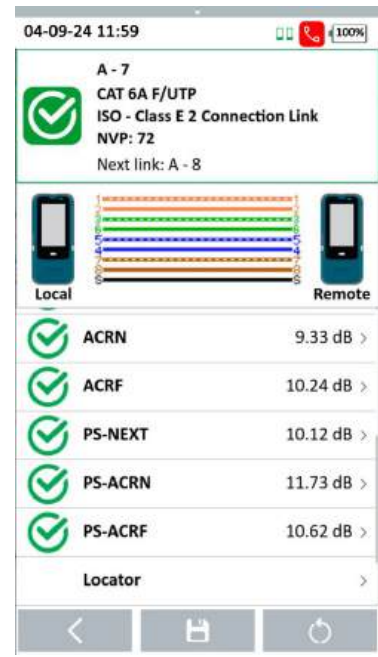

Tap on the wiremap diagram to view the wiremap test result or select the parameter from the list to view the details of individual result.

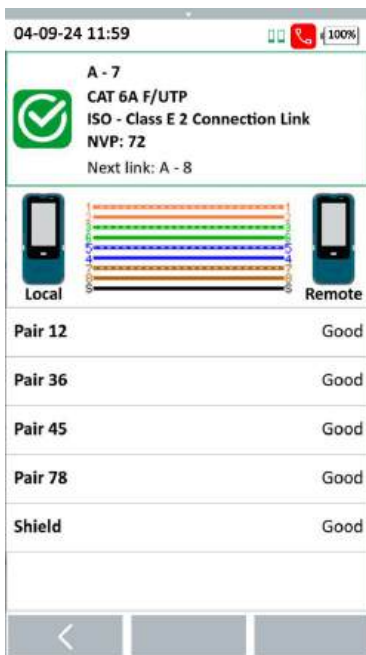

Wiremap

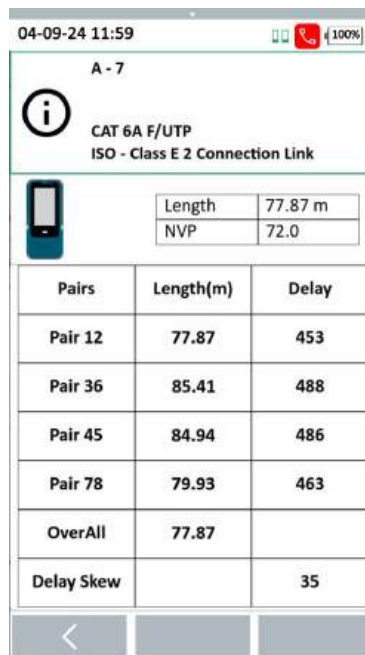

Length & Delay

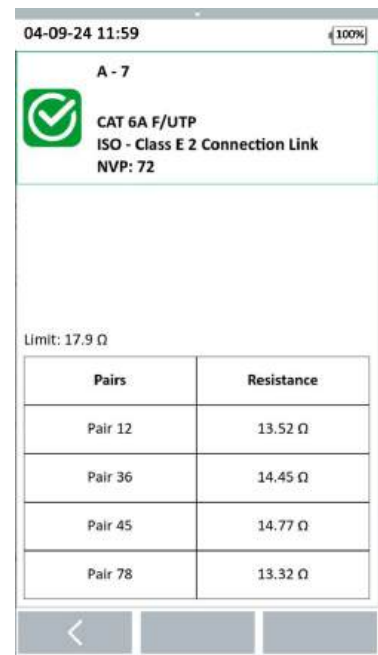

DC Loop Resistance²



DCRU Loop Resistance

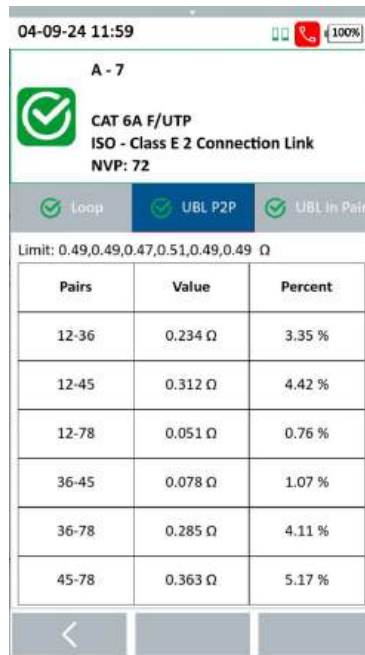

DCRU Unbalance between Pairs

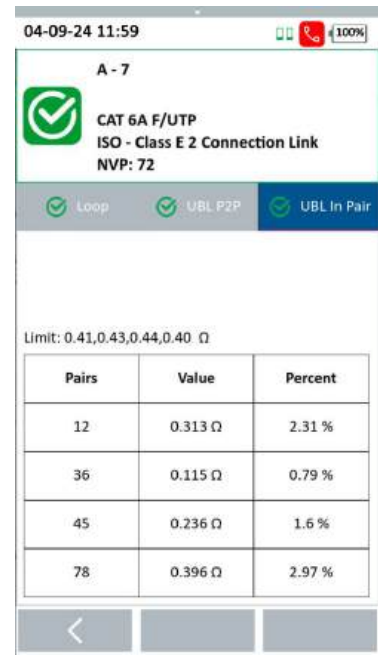

DCRU Unbalance in a Pair

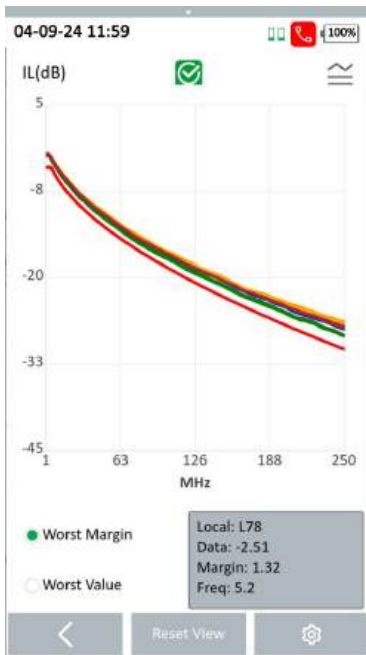

Insertion Loss

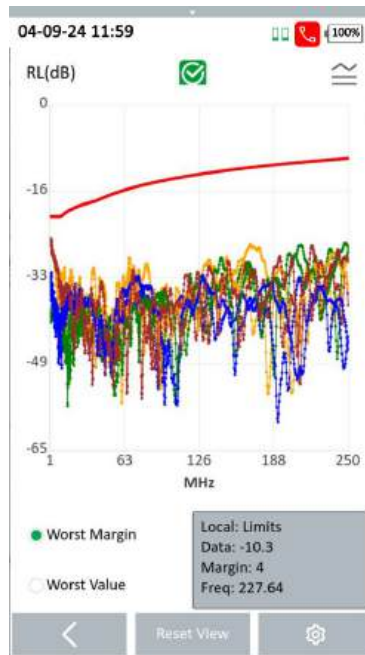

Return Loss

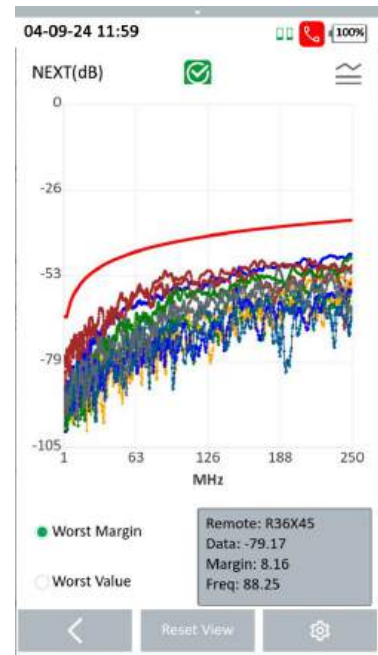

Near-end Crosstalk (NEXT)

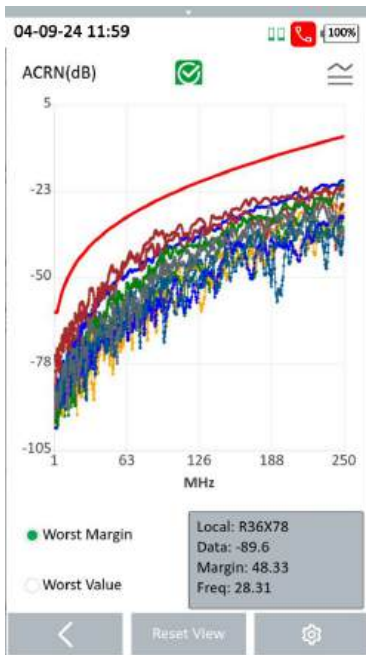

³Attenuation to Crosstalk Ratio (ACR-N)

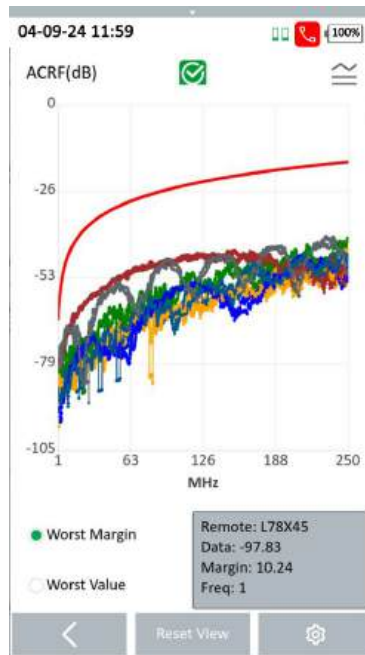

Attenuation to Crosstalk Ratio, Far-end (ACR-F)

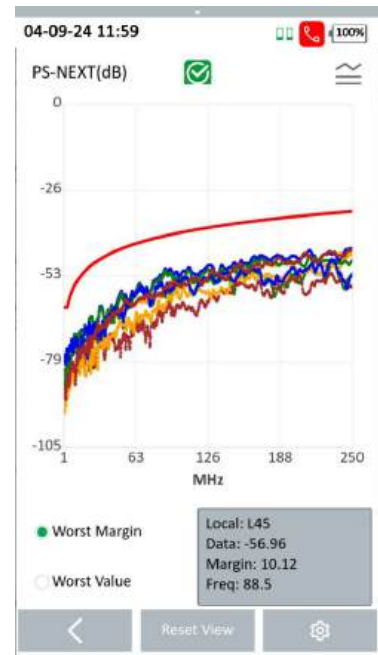

Power-sum NEXT (PSNEXT)

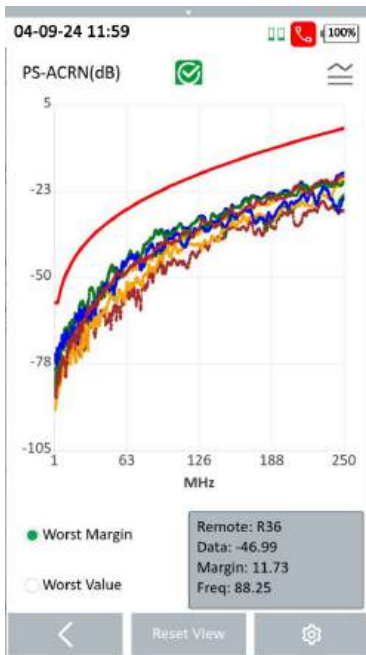

Power-sum ACR-N (PSACRN)

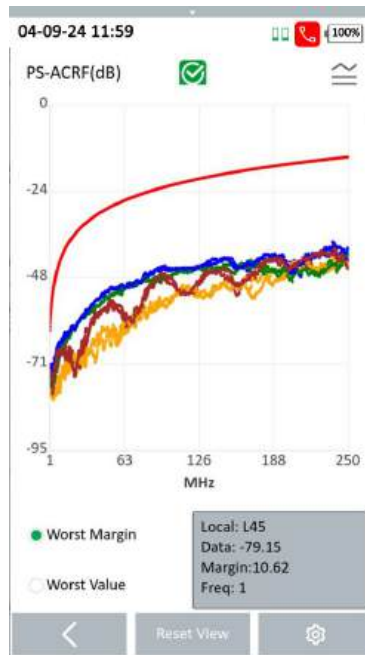

Power-sum ACR-F (PSACRF)

In plot view (Insertion Loss, Return Loss, NEXT), select [**Worst Margin**] to view the worst margin or [**Worst Value**] to view the worst value.

Pinch in or out on the screen to perform magnification on the plot diagram. Tap [**Reset Zoom**] to return to reset magnification.

Select [**Settings**] to select what information will be displayed on the plot.

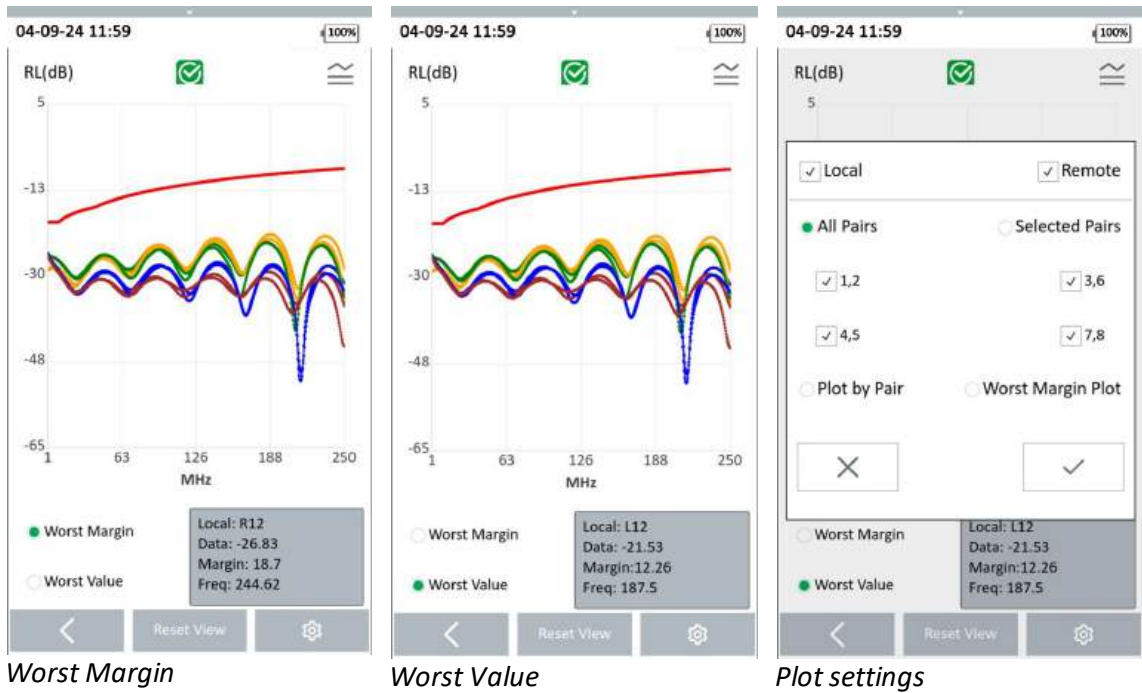

Rotate the device to the to view the plot on a landscape orientation. The landscape view is only available for viewing of plots. Rotate device to upright position to return to the portrait orientation.

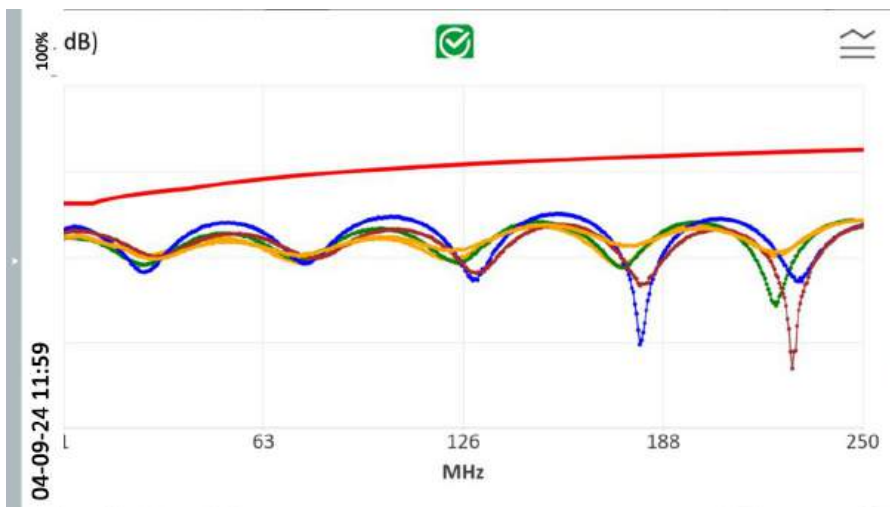

Rotated view



Note

- ¹ Parameters that are only required as "information-only" will be displayed with a "info" status instead of a "pass" or "fail" status.
- ² Only DC Loop Resistance values will be displayed if DCRU is disabled in the Test Settings.
- ³ The parameters displayed in the results is dependent on the selected test limit. Parameters that are not required for the selected test limit will not be displayed.

4.4 Managing test result(s)

Test results can be manually saved by selecting **[Save]** after an Autotest or single application test in Tools is completed. When prompted, enter label name and tap the **[Save]** button to save.

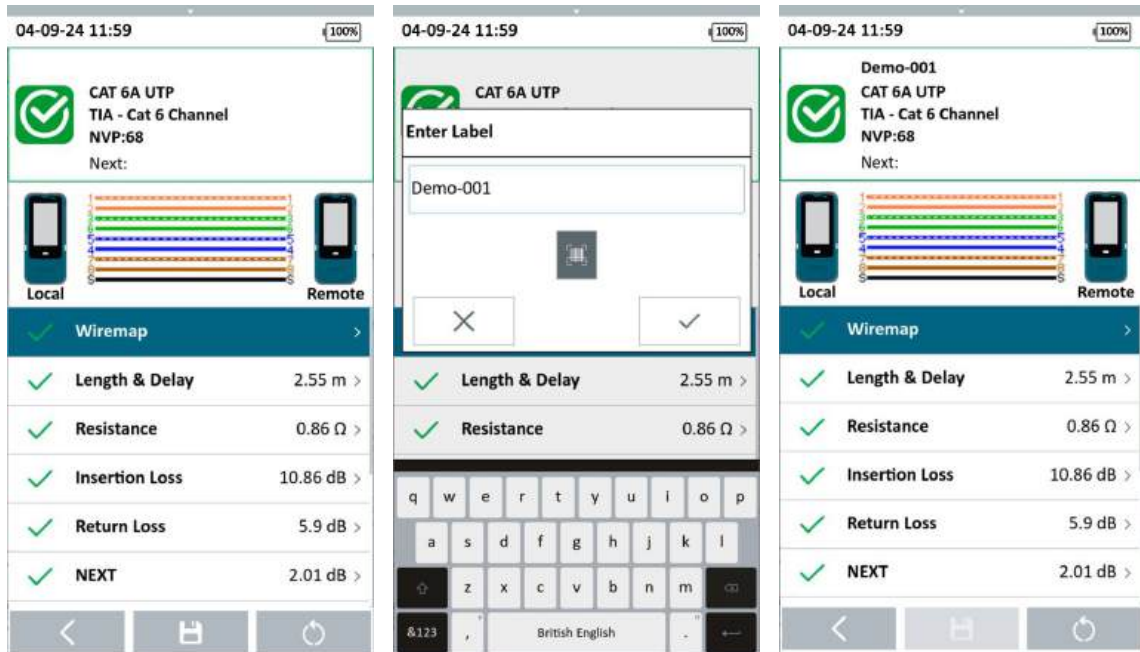

Autotest result screen

Enter label

*The **[Save]** icon will disappear once saving is completed.*

Test results will be named in alpha-numeric sequence depending on the selected [Label Source](#) when Autotest is completed.

PASS results will automatically be saved if the **Auto Save** option is enabled. FAILED results can only be saved manually.

Exporting test results into eXport PC Software

eXport is a data management software designed to work seamlessly with WireXpert MP. Saved results can be exported using the following methods;

USB Flash Drive

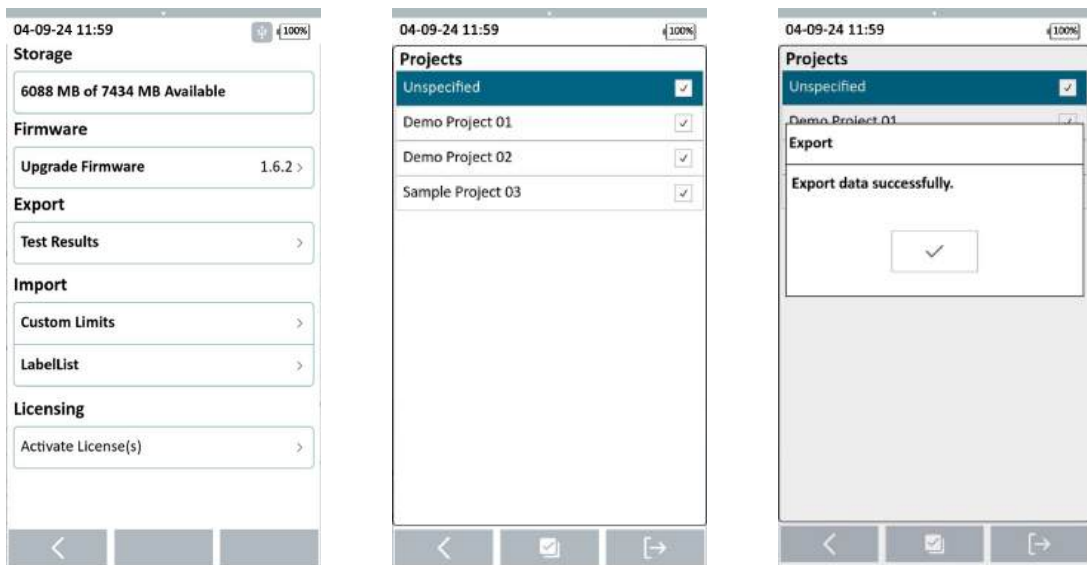

1. Insert USB flash drive to the USB port on WireXpert MP.
2. Device will automatically detect flash drive.
3. Otherwise, tap the USB icon  on the status bar and select **[Open]**.
4. Select **[Test Results]**.
5. Select projects to export and tap the **[Export]**  button..
6. Tap the **[Okay]**  to proceed.
7. Launch eXport software.
8. Go to File  Create New Project to create new project space.
9. Go to Import  USB Flash Drive and select the flash drive. Click **[Import]**.
10. Select database and click **[Import Selected]** to import or click **[Import All]** for all databases.



User Manuals

Refer “User Manual – eXport” for more information on how to use the software.

5 Technical Support

Softing's global presence ensures our customers receives sales and technical support anywhere around the world. For more information please visit <https://itnetworks.softing.com/contact/>.

Asia/Pacific

Softing Singapore Pte. Ltd.

73 Science Park Drive
#02-12/13, Cintech I
Singapore Science Park 1
Singapore 118254

Phone: +65-6569-6019
E-mail: asia-sales.itnetwork@softing.com

Europe/Middle East/Africa

Softing IT Networks GmbH

Richard-Reitzner-Alle 6
D-85540 Haar, Munich

Phone: +49 89 45 656 660
E-mail: info.itnetworks@softing.com

Softing Italia Srl.

Via M. Kolbe, 6
20090 Cesano Boscone (MI)

Phone: +39 02 4505171
E-mail: info@softingitalia.it

China

Softing Shanghai

604, Building 8A, Jinke Office Park,
No.358 Jinhu Road, Pudong District,
Shanghai 201206
China

Phone: +86 (21) 61063031
E-mail: info@softingchina.cn

The Americas

Softing Inc.

2332 News Sentinel Drive,
Suite 120
Knoxville TN 37921

Phone: +1 865 251 5252
E-mail: sales@softing.us

Softing SRL

14 avenue de l'Opéra
75001 Paris
France

Phone: +33 1451 72805
E-mail: info.france@softing.com

Buxbaum Automation GmbH

Eisenstadt

Phone: +43 2682 7045 60
E-Mail: office@myautomation.at



**Ihr Ansprechpartner /
Your Partner:**

dataTec AG
E-Mail: info@datatec.eu
>>> www.datatec.eu

Mess- und Prüftechnik. Die Experten.