



Mess- und Prüftechnik. Die Experten.

Ihr Ansprechpartner /
Your Partner:

dataTec AG
E-Mail: info@datatec.eu
>>> www.datatec.eu



RS8513 - Fully Enclosed Version w/ GigE, CXP

P/N: 29442-213

Copyright

© 2023, FLIR Systems, Inc.

All rights reserved worldwide. Names and marks appearing herein are either registered trademarks or trademarks of FLIR Systems and/or its subsidiaries. All other trademarks, trade names or company names referenced herein are used for identification only and are the property of their respective owners.

Document identity

Publ. No.: 29442-213

Commit: 92601

Language:

Modified: 2023-06-26

Formatted: 2023-06-26

Website

<http://www.flir.com>

Customer support

<http://support.flir.com>

Disclaimer

Specifications subject to change without further notice. Camera models and accessories subject to regional market considerations. License procedures may apply. Products described herein may be subject to US Export Regulations. Please refer to exportquestions@flir.com with any questions.



Detector data	
Detector Type	FLIR Indium Antimonide (InSb)
Spectral Range	3.0 – 5.0 μm
Resolution	1280 x 1024
Detector Pitch	12 μm
Thermal Sensitivity/NETD, typical	25 mK typical
Well Capacity	Gain 0: 3.0 Me-, Gain 1: 11.5 Me-
Operability	99.5% (> 99.9% typical)
Sensor Cooling	Closed-cycle linear Stirling cooler
Electronics	
Readout Type	Snapshot
Readout Modes	Asynchronous integrate while read Asynchronous integrate then read
Synchronization Modes	Sync In, Sync Out, Trigger In
Image Time Stamp	Internal precision timestamp. IRIG-B AM decoder, TSPI accurate
Integration Time	270 ns to ~Full frame
Pixel Clock	355 MHz
Frame Rate (Full Window)	Programmable; 0.5 Hz to 181 Hz
Subwindow Mode	Flexible windowing down to 64 x 4 (steps of 64 columns, 4 rows)
Dynamic Range	14-bit
On-Camera Image Storage	RAM (volatile): 16 GB, up to 6,100 frames (future feature)
Radiometric Data Streaming	Gigabit Ethernet (GigE Vision), CXP Dual Link
Standard Video	HD-SDI
Command and Control	GigE, RS-232, CXP (GenICam protocol supported over GigE or CXP)
Optics	
Camera f/Number	f/5
Lens	120-1200 mm Zoom (low-latency metadata, metric)
Focus	Motorized FOV/Focus
Lens Cover	Optional, Motorized
ND Filter Wheel	4-position motorized filter wheel, standard 1-inch ND filters must be factory installed



Mess- und Prüftechnik. Die Experten.

Ihr Ansprechpartner /
Your Partner:

dataTec AG
E-Mail: info@datatec.eu
>>> www.datatec.eu



RS8513 - Fully Enclosed Version w/ GigE, CXP

P/N: 29442-213

© 2023, FLIR Systems, Inc.
#29442-213; r. 92601;

Image/Video Presentation	
Palettes	Selectable 8-bit
Automatic Gain Control	Manual, Linear, Plateau equalization, ROI, DDE
Overlay	Customizable
Video Modes	HD: 720p/59.9/50Hz, 1080p/29.9/25Hz
Digital Zoom	1x, 4x, 4:3
General	
Operating Temperature Range	-20 to 50°C (-4 to 122°F)
Chassis IP Rating	IP65
Power	24 VDC nominal, 20-28 V acceptable (< 50 W steady state)
Weight	Approx. 43.2 kg (95 lbs)
Size (L x W x H)	889 x 308 x 312 mm (35 x 12.125 x 12.3 in)
Mounting	15 x 3/8"-16 tapped holes
Declaration of conformity	See: https://support.flir.com/resources/DoC

Supplies & accessories:

- 26431-000; Power connector
- 4228270; Science Camera Power Supply (RS8xxx and RS67xx)
- 4232535; FLIR Research Studio, Professional Edition - 1 Year Subscription (online activation)
- 4232556; FLIR Research Studio, Professional Edition - Perpetual License (online activation)
- 4232590; FLIR Research Studio, Professional Edition - Perpetual License (USB dongle)
- 4220499; FLIR Research Studio, Standard Edition - 1 Year Subscription (online activation)
- 4220500; FLIR Research Studio, Standard Edition - Perpetual License (online activation)
- 4220646; FLIR Research Studio, Standard Edition - Perpetual License (USB dongle)
- 4232591; FLIR ResearchIR to Research Studio, Professional Edition - 1 Year License Upgrade
- 4224157; FLIR Science Camera SDK
- 4216760; FLIR Science File SDK

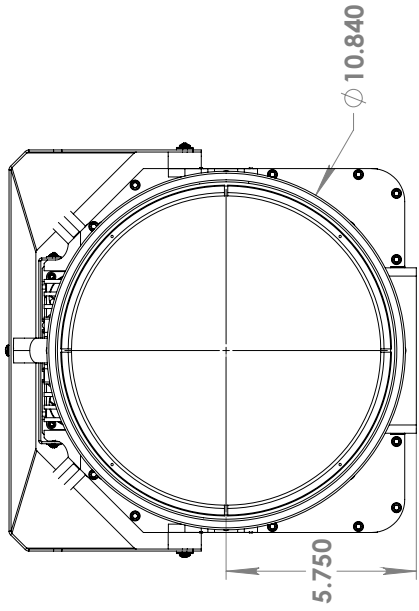
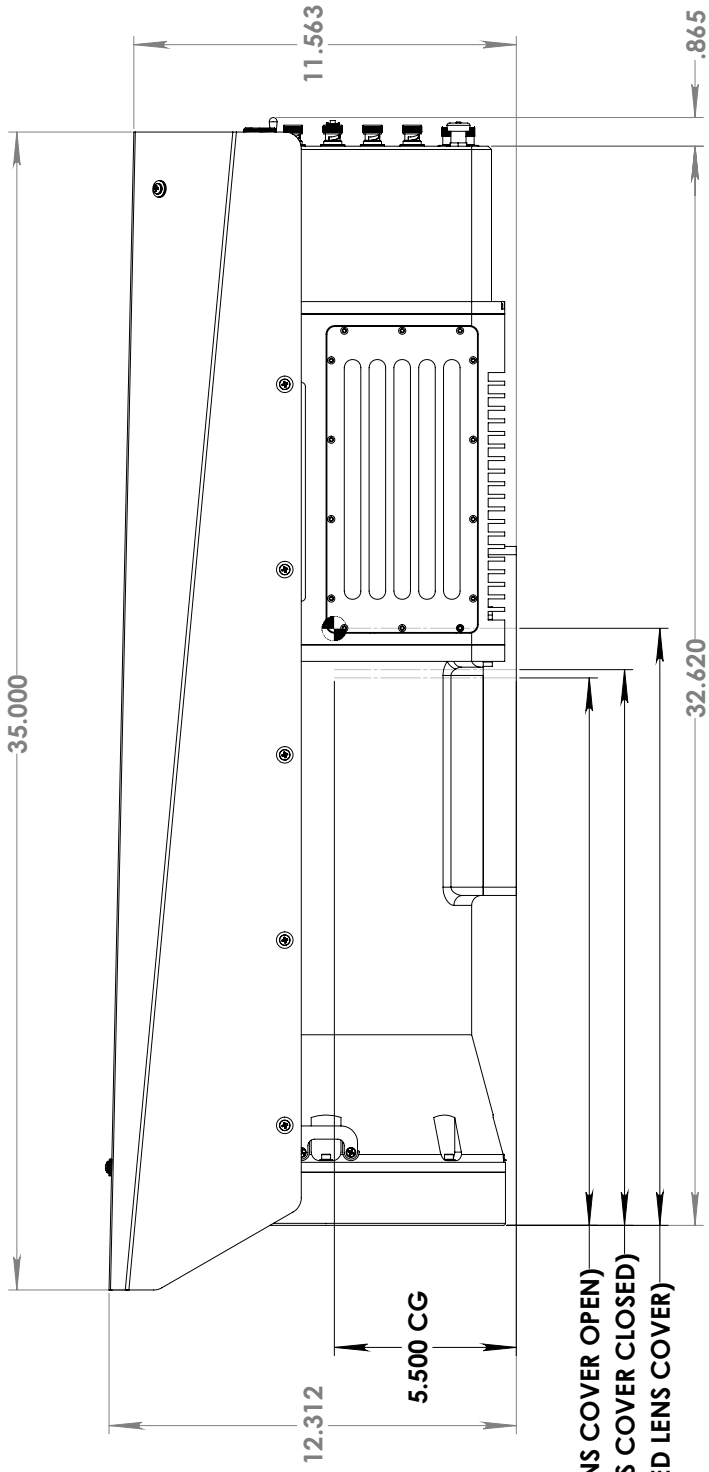

- 16.547 CG (MOTORIZED LENS COVER OPEN)
- 16.797 CG (MOTORIZED LENS COVER CLOSED)
- 18.047 CG (NO MOTORIZED LENS COVER)

